

# **Monochrome Laser MFP**

---

## **User's Guide**



# Contents

<b>Safety information.....</b>	<b>12</b>
<b>Learning about the printer.....</b>	<b>14</b>
Printer configurations.....	14
Selecting a location for the printer.....	14
Basic functions of the scanner.....	15
Understanding the ADF and scanner glass.....	16
Understanding the printer control panel.....	17
Understanding the home screen.....	18
Using the touch-screen buttons.....	20
<b>Additional printer setup.....</b>	<b>24</b>
Installing internal options.....	24
Available internal options.....	24
Accessing the system board to install internal options.....	25
Installing a memory card.....	27
Installing a flash memory or firmware card.....	28
Installing an Internal Solutions Port.....	31
Installing a printer hard disk.....	37
Installing a fax card.....	41
Attaching cables.....	43
Verifying printer setup.....	44
Printing a menu settings page.....	44
Printing a network setup page.....	45
Setting up the printer software.....	45
Installing printer software.....	45
Updating available options in the printer driver.....	46
Setting up wireless printing.....	47
Information you will need to set up the printer on a wireless network.....	47
Installing the printer on a wireless network (Windows).....	47
Installing the printer on a wireless network (Macintosh).....	49
Installing the printer on a wired network.....	52
Changing port settings after installing a new network Internal Solutions Port.....	55
Setting up serial printing.....	57
Setting up the printer to fax.....	59
Choosing a fax connection.....	59
Using an RJ11 adapter.....	60

Connecting directly to a telephone wall jack in Germany.....	63
Connecting to a telephone .....	64
Connecting to an answering machine.....	65
Connecting to a computer with a modem.....	67
Setting the outgoing fax name and number.....	68
Setting the date and time.....	68
Turning Daylight Saving Time on .....	69

## **Loading paper and specialty media.....70**

Setting the Paper Size and Paper Type.....	70
Configuring Universal paper settings.....	70
Loading the standard or optional 250-sheet or 550-sheet tray.....	71
Loading the 2000-sheet tray.....	74
Loading the multipurpose feeder.....	78
Loading the envelope feeder.....	80
Linking and unlinking trays.....	81
Linking trays.....	81
Unlinking trays.....	82
Assigning a custom paper type name.....	82
Changing a Custom Type <x> name .....	82

## **Paper and specialty media guidelines.....84**

Paper guidelines.....	84
Paper characteristics.....	84
Unacceptable paper .....	85
Selecting paper.....	85
Selecting preprinted forms and letterhead.....	85
Using recycled paper and other office papers .....	86
Storing paper.....	86
Supported paper sizes, types, and weights.....	87
Paper sizes supported by the printer .....	87
Paper types and weights supported by the printer .....	89
Paper types and weights supported by the output bins .....	89

## **Copying.....91**

Making copies.....	91
Making a quick copy.....	91
Copying using the ADF.....	91
Copying using the scanner glass .....	92
Copying photos.....	92
Copying on specialty media.....	92
Making transparencies.....	92

Copying to letterhead.....	93
Customizing copy settings.....	93
Copying from one size to another.....	93
Making copies using paper from a selected tray .....	94
Copying a document that contains mixed paper sizes.....	94
Copying on both sides of the paper (duplexing) .....	95
Reducing or enlarging copies .....	95
Adjusting copy quality.....	96
Collating copies.....	96
Placing separator sheets between copies .....	97
Copying multiple pages onto a single sheet.....	97
Creating a custom job (job build) .....	98
Job interrupt.....	99
Placing information on copies.....	99
Placing the date and time at the top of each page .....	99
Placing an overlay message on each page.....	99
Canceling a copy job.....	100
Canceling a copy job while the document is in the ADF .....	100
Canceling a copy job while copying pages using the scanner glass .....	100
Canceling a copy job while the pages are being printed .....	100
Understanding the copy screens and options.....	100
Copy from.....	100
Copy to .....	101
Scale.....	101
Darkness.....	101
Content.....	101
Sides (Duplex) .....	101
Collate .....	102
Options .....	102
Improving copy quality.....	103

## **E-mailing.....104**

Getting ready to e-mail.....	104
Setting up the e-mail function .....	104
Configuring the e-mail settings.....	105
Creating an e-mail shortcut.....	105
Creating an e-mail shortcut using the Embedded Web Server .....	105
Creating an e-mail shortcut using the touch screen.....	105
E-mailing a document.....	106
Sending an e-mail using the touch screen .....	106
Sending an e-mail using a shortcut number .....	106
Sending an e-mail using the address book.....	106

Customizing e-mail settings.....	107
Adding e-mail subject and message information.....	107
Changing the output file type.....	107
Canceling an e-mail.....	108
Understanding e-mail options.....	108
Original Size .....	108
Sides (Duplex) .....	108
Orientation .....	108
Binding .....	108
E-mail Subject .....	108
E-mail File Name.....	109
E-mail Message.....	109
Resolution.....	109
Send As.....	109
Content.....	109
Advanced Options.....	109

## **Faxing.....111**

Sending a fax.....	111
Sending a fax using the printer control panel.....	111
Sending a fax using the computer .....	112
Creating shortcuts.....	112
Creating a fax destination shortcut using the Embedded Web Server.....	112
Creating a fax destination shortcut using the touch screen.....	113
Using shortcuts and the address book.....	113
Using fax shortcuts.....	113
Using the address book.....	113
Customizing fax settings.....	114
Changing the fax resolution .....	114
Making a fax lighter or darker .....	114
Sending a fax at a scheduled time.....	115
Viewing a fax log.....	115
Blocking junk faxes.....	115
Canceling an outgoing fax.....	116
Canceling a fax while the original documents are still scanning .....	116
Canceling a fax after the original documents have been scanned to memory .....	116
Understanding fax options.....	116
Original Size .....	116
Content.....	117
Sides (Duplex) .....	117
Resolution.....	117
Darkness.....	117
Advanced Options.....	117

Improving fax quality.....	118
Holding and forwarding faxes.....	118
Holding faxes.....	118
Forwarding a fax .....	119
<b>Scanning to an FTP address.....</b>	<b>120</b>
Scanning to an FTP address.....	120
Scanning to an FTP address using the keypad .....	120
Scanning to an FTP address using a shortcut number.....	121
Scanning to an FTP address using the address book .....	121
Creating shortcuts.....	121
Creating an FTP shortcut using the Embedded Web Server.....	121
Creating an FTP shortcut using the touch screen.....	122
Understanding FTP options.....	122
Original Size .....	122
Sides (Duplex) .....	122
Orientation .....	122
Binding .....	122
Resolution.....	123
Send As.....	123
Content.....	123
Advanced Options.....	123
Improving FTP quality.....	124
<b>Scanning to a computer or flash drive.....</b>	<b>125</b>
Scanning to a computer.....	125
Scanning to a flash drive.....	126
Understanding scan profile options.....	126
Quick Setup.....	126
Format Type.....	127
Compression.....	127
Default Content.....	127
Color .....	127
Original Size .....	127
Orientation .....	127
Sides (Duplex) .....	127
Darkness.....	128
Resolution.....	128
Advanced Imaging .....	128
Improving scan quality.....	128

<b>Printing.....</b>	<b>129</b>
Printing a document.....	129
Printing on specialty media.....	129
Tips on using letterhead.....	129
Tips on using transparencies.....	130
Tips on using envelopes.....	130
Tips on using labels.....	131
Tips on using card stock.....	131
Printing confidential and other held jobs.....	132
Holding jobs in the printer .....	132
Printing confidential and other held jobs from Windows .....	132
Printing confidential and other held jobs from a Macintosh computer.....	133
Printing from a flash drive.....	134
Printing information pages.....	135
Printing a directory list.....	135
Printing the print quality test pages .....	135
Canceling a print job.....	135
Canceling a print job from the printer control panel .....	135
Canceling a print job from the computer .....	136
 <b>Clearing jams.....</b>	 <b>138</b>
Avoiding jams.....	138
Understanding jam numbers and locations.....	139
200 and 201 paper jams.....	139
202 paper jam.....	141
230–239 paper jams.....	142
240–249 paper jams.....	143
250 paper jam.....	144
260 paper jam.....	145
270–279 paper jams.....	145
280–282 paper jams.....	145
283 staple jams.....	146
290–294 paper jams.....	148
 <b>Understanding printer menus.....</b>	 <b>150</b>
Menu list.....	150
Paper menu.....	151
Default Source menu.....	151
Paper Size/Type menu .....	151

Configure MP menu.....	154
Envelope Enhance.....	155
Substitute Size menu.....	155
Paper Texture menu .....	155
Paper Weight menu.....	157
Paper Loading menu .....	158
Custom Types menu.....	159
Custom Names menu.....	160
Custom Scan Sizes menu .....	160
Custom Bin Names menu .....	160
Universal Setup menu.....	161
Bin Setup menu .....	161
Reports menu.....	162
Network/Ports menu.....	164
Active NIC menu.....	164
Standard Network or Network <x> menus .....	164
SMTP Setup menu .....	166
Network Reports menu .....	167
Network Card menu.....	167
TCP/IP menu.....	167
IPv6 menu.....	169
Wireless menu.....	169
AppleTalk menu .....	170
NetWare menu.....	170
LexLink menu .....	171
Standard USB menu.....	171
Parallel <x> menu.....	173
Serial <x> menu .....	175
Security menu.....	177
Miscellaneous menu.....	177
Confidential Print menu .....	178
Disk Wiping menu .....	179
Security Audit Log menu .....	180
Set Date/Time menu.....	181
Settings menu.....	181
General Settings menu .....	181
Copy Settings menu .....	189
Fax Settings menu.....	194
E-mail Settings menu .....	203
FTP Settings menu.....	208
Flash Drive menu .....	211
Print Settings .....	216
Help menu.....	228



<b>Understanding printer messages.....</b>	<b>229</b>
List of status and error messages.....	229
<b>Maintaining the printer.....</b>	<b>248</b>
Cleaning the exterior of the printer.....	248
Cleaning the scanner glass.....	248
Adjusting scanner registration.....	249
Storing supplies.....	250
Conserving supplies.....	251
Checking the status of supplies.....	251
Checking the status of supplies from the printer control panel.....	251
Checking the status of supplies from a network computer .....	251
Ordering supplies.....	252
Ordering print cartridges .....	252
Moving the printer.....	252
Before moving the printer .....	252
Moving the printer to another location.....	253
Setting the printer up in a new location .....	253
Shipping the printer .....	253
<b>Administrative support.....</b>	<b>254</b>
Using the Embedded Web Server.....	254
Checking the device status.....	254
Setting up e-mail alerts.....	254
Viewing reports.....	255
Adjusting the brightness of the display.....	255
Adjusting Power Saver.....	255
Restoring the factory default settings.....	256
<b>Troubleshooting.....</b>	<b>257</b>
Solving basic printer problems.....	257
Printer control panel display is blank or displays only diamonds.....	257
Solving printing problems.....	257
Multiple-language PDFs do not print.....	257
Error message about reading USB drive appears.....	257
Jobs do not print.....	258
Confidential and other held jobs do not print .....	258
Job takes longer than expected to print .....	259
Job prints from the wrong tray or on the wrong paper .....	259

Incorrect characters print.....	259
Tray linking does not work.....	260
Large jobs do not collate .....	260
Unexpected page breaks occur.....	260
Solving copy problems.....	261
Copier does not respond .....	261
Scanner unit does not close.....	261
Poor copy quality.....	261
Partial document or photo copies.....	263
Solving scanner problems.....	263
Checking an unresponsive scanner .....	263
Scan was not successful .....	263
Scanning takes too long or freezes the computer.....	264
Poor scanned image quality .....	264
Partial document or photo scans.....	264
Cannot scan from a computer .....	265
Solving fax problems.....	265
Caller ID is not shown.....	265
Cannot send or receive a fax.....	265
Can send but not receive faxes.....	267
Can receive but not send faxes.....	268
Received fax has poor print quality.....	268
Solving option problems.....	269
Option does not operate correctly or quits after it is installed .....	269
Paper trays.....	269
2000-sheet tray.....	270
Envelope feeder .....	270
Output options .....	271
Flash memory card.....	271
Hard disk with adapter.....	271
Internal Solutions Port .....	271
Memory card .....	271
Solving paper feed problems.....	272
Paper frequently jams .....	272
Paper jam message remains after jam is cleared .....	272
Page that jammed does not reprint after you clear the jam.....	272
Solving print quality problems.....	273
Isolating print quality problems.....	273
Blank pages.....	273
Characters have jagged or uneven edges .....	274
Clipped images.....	274
Ghost images.....	274
Gray background .....	275

Incorrect margins.....	275
Paper curl.....	276
Print irregularities .....	276
Repeating defects.....	277
Skewed print.....	278
Solid black or white streaks.....	278
Print is too light .....	279
Print is too dark.....	280
Solid color pages.....	281
Streaked vertical lines .....	281
Toner fog or background shading appears on the page .....	282
Toner rubs off .....	282
Toner specks.....	283
Transparency print quality is poor.....	283
Embedded Web Server does not open.....	283
Check the network connections .....	283
Check the network settings .....	284
Contacting Customer Support.....	284

**Notices.....285**

Edition notice.....	285
Industry Canada notices.....	286
Power consumption.....	293

**Index.....295**

# Safety information

Connect the power cord to a properly grounded electrical outlet that is near the product and easily accessible.

Do not place or use this product near water or wet locations.

 **CAUTION—POTENTIAL INJURY:** This product uses a laser. Use of controls or adjustments or performance of procedures other than those specified herein may result in hazardous radiation exposure.

This product uses a printing process that heats the print media, and the heat may cause the media to release emissions. You must understand the section in your operating instructions that discusses the guidelines for selecting print media to avoid the possibility of harmful emissions.

Use care when you replace a lithium battery.

 **CAUTION—POTENTIAL INJURY:** There is a danger of explosion if a lithium battery is incorrectly replaced. Replace it only with the same or an equivalent type of lithium battery. Do not recharge, disassemble, or incinerate a lithium battery. Discard used batteries according to the manufacturer's instructions and local regulations.

 **CAUTION—HOT SURFACE:** The inside of the printer might be hot. To reduce the risk of injury from a hot component, allow the surface to cool before touching.

 **CAUTION—POTENTIAL INJURY:** The printer weight is greater than 18 kg (40 lb) and requires two or more trained personnel to move it safely.

 **CAUTION—POTENTIAL INJURY:** Before moving the printer, follow these guidelines to avoid personal injury or printer damage:

- Turn the printer off using the power switch, and then unplug the power cord from the wall outlet.
- Disconnect all cords and cables from the printer before moving it.
- Lift the printer off of the optional drawer and set it aside instead of trying to lift the drawer and printer at the same time.

**Note:** Use the handholds located on both sides of the printer to lift it off the optional drawer.

Use only the power cord provided with this product or the manufacturer's authorized replacement.

Use only the telecommunications (RJ-11) cord provided with this product or a 26 AWG or larger replacement when connecting this product to the public switched telephone network.

 **CAUTION—SHOCK HAZARD:** If you are accessing the system board or installing optional hardware or memory devices sometime after setting up the printer, then turn the printer off, and unplug the power cord from the wall outlet before continuing. If you have any other devices attached to the printer, then turn them off as well, and unplug any cables going into the printer.

 **CAUTION—SHOCK HAZARD:** Make sure that all external connections (such as Ethernet and telephone system connections) are properly installed in their marked plug-in ports.

This product is designed, tested, and approved to meet strict global safety standards with the use of specific manufacturer's components. The safety features of some parts may not always be obvious. The manufacturer is not responsible for the use of other replacement parts.

 **CAUTION—POTENTIAL INJURY:** Do not twist, bind, crush, or place heavy objects on the power cord. Do not subject the power cord to abrasion or stress. Do not pinch the power cord between objects such as furniture and walls. If the power cord is misused, a risk of fire or electrical shock results. Inspect the power cord regularly for signs of misuse. Remove the power cord from the electrical outlet before inspecting it.

Refer service or repairs, other than those described in the user documentation, to a professional service person.

 **CAUTION—SHOCK HAZARD:** To avoid the risk of electric shock when cleaning the exterior of the printer, unplug the power cord from the wall outlet and disconnect all cables from the printer before proceeding.

 **CAUTION—SHOCK HAZARD:** Do not use the fax feature during a lightning storm. Do not set up this product or make any electrical or cabling connections, such as the fax feature, power cord, or telephone, during a lightning storm.

 **CAUTION—TIPPING HAZARD:** Floor-mounted configurations require additional furniture for stability. You must use either a printer stand or printer base if you are using a high-capacity input tray, a duplex unit and an input option, or more than one input option. If you purchased a multifunction printer (MFP) that scans, copies, and faxes, you may need additional furniture. For more information, see [www.infoprint.com/literature/workgroupconfig](http://www.infoprint.com/literature/workgroupconfig).

**SAVE THESE INSTRUCTIONS.**

# Learning about the printer

## Printer configurations

**Note:** Printer configuration may vary depending on your printer model.

### Basic models

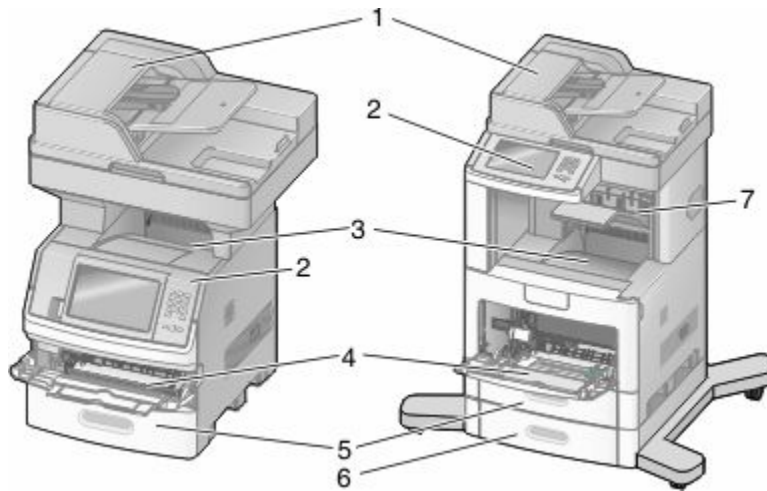

1	Automatic Document Feeder (ADF)
2	Printer control panel
3	Standard exit bin
4	Multipurpose feeder
5	550-sheet tray (Tray 1)
6	550-sheet tray (Tray 2)
7	Optional output bin

## Selecting a location for the printer

When selecting a location for the printer, leave enough room to open trays, covers, and doors. If you plan to install any options, leave enough room for them also. It is important to:

- Make sure airflow in the room meets the latest revision of the ASHRAE 62 standard.
- Provide a flat, sturdy, and stable surface.
- Keep the printer:
  - Away from the direct airflow of air conditioners, heaters, or ventilators
  - Free from direct sunlight, humidity extremes, or temperature fluctuations
  - Clean, dry, and free of dust
- Allow the following recommended amount of space around the printer for proper ventilation:

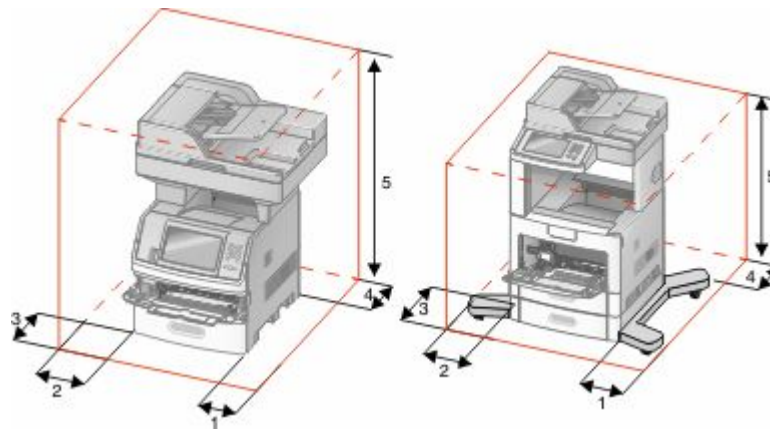

1	Right Side	20 cm (8 in.)
2	Left Side	31 cm (12 in.)
3	Front	51 cm (20 in.)
4	Rear	20 cm (8 in.)
5	Top	31 cm (12 in.)

## Basic functions of the scanner

The scanner provides copy, fax, and scan-to-network capability for large workgroups. You can:

- Make quick copies, or change the settings on the printer control panel to perform specific copy jobs.
- Send a fax using the printer control panel.
- Send a fax to multiple fax destinations at the same time.
- Scan documents and send them to your computer, an e-mail address, a flash drive, or an FTP destination.
- Scan documents and send them to another printer (PDF by way of FTP).

# Understanding the ADF and scanner glass

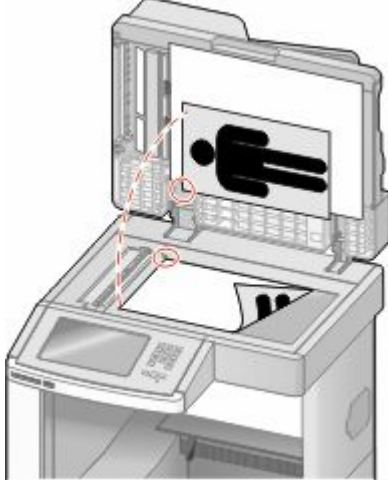
Automatic Document Feeder (ADF)	Scanner glass
 <p data-bbox="149 793 623 825">Use the ADF for multiple-page documents.</p>	 <p data-bbox="643 793 1442 888">Use the scanner glass for single pages, small items (such as postcards or photos), transparencies, photo paper, or thin media (such as magazine clippings or lightweight carbonless forms).</p>

You can use the ADF or the scanner glass to scan documents.

## Using the ADF

The Automatic Document Feeder (ADF) can scan multiple pages, including duplex pages. When using the ADF:

- Load the document into the ADF faceup, short edge first.
- Load up to 75 sheets of plain paper in the ADF input tray.
- Scan sizes from 76.2 x 139.4 mm (3.0 x 5.5 in.) to 215.9 x 355.6 mm (8.5 x 14 in.).
- Scan documents with mixed page sizes (letter and legal).
- Scan media weights from 52 to 120 g/m<sup>2</sup> (14 to 32 lb).
- Do not load postcards, photos, small items, transparencies, photo paper, or thin media (such as magazine clippings) into the ADF. Place these items on the scanner glass.

## Using the scanner glass

The scanner glass can be used to scan or copy single pages or book pages. When using the scanner glass:





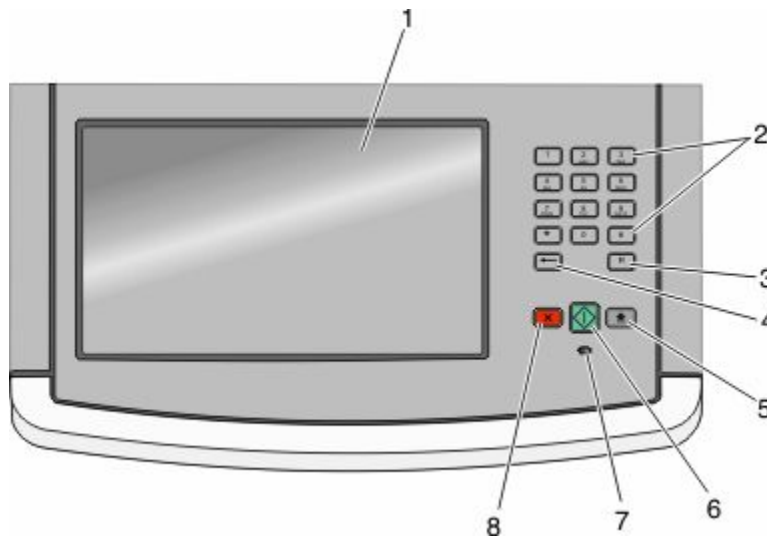

- Place a document facedown on the scanner glass in the upper left corner.
- Scan or copy documents up to 215.9 x 355.6 mm (8.5 x 14 in.).
- Copy books up to 25.3 mm (1 in.) thick.



# Understanding the printer control panel



Item		Description
1	Display	View scanning, copying, faxing, and printing options as well as status and error messages.
2	Keypad	Enter numbers or symbols on the display.
3	Dial Pause	<ul style="list-style-type: none"> <li>Press  to cause a two- or three-second dial pause in a fax number. In the Fax To field, a Dial Pause is represented by a comma (,).</li> <li>From the home screen, press  to redial a fax number.</li> <li>The button functions only within the Fax menu or with fax functions. When outside of the Fax menu, fax function, or home screen, pressing  causes an error beep.</li> </ul>
4	Back	<p>In the Copy menu, press  to delete the right-most digit of the value in the Copy Count. The default value of 1 appears if the entire number is deleted by pressing  numerous times.</p> <p>In the Fax Destination List, press  to delete the right-most digit of a number entered manually. You can also press  to delete an entire shortcut entry. Once an entire line is deleted, another press of  causes the cursor to move up one line.</p> <p>In the E-mail Destination List, press  to delete the character to the left of the cursor. If the character is in a shortcut, then the shortcut is deleted.</p>

Item		Description
5	Home 	Press  to return to the home screen.
6	Start 	<ul style="list-style-type: none"> <li>• Press  to initiate the current job indicated on the display.</li> <li>• From the home screen, press  to start a copy job with the default settings.</li> <li>• If pressed while a job is scanning, the button has no effect.</li> </ul>
7	Indicator light	Indicates the printer status: <ul style="list-style-type: none"> <li>• <b>Off</b>—The power is off.</li> <li>• <b>Blinking green</b>—The printer is warming up, processing data, or printing.</li> <li>• <b>Solid green</b>—The printer is on, but idle.</li> <li>• <b>Blinking red</b>—Operator intervention is needed.</li> </ul>
8	Stop 	Stops all printer activity A list of options is offered once <b>Stopped</b> appears on the display.

## Understanding the home screen

After the printer is turned on and a short warm-up period occurs, the display shows the following basic screen which is referred to as the home screen. Use the home screen buttons to initiate an action such as copying, faxing, or scanning; to open the menu screen; or to respond to messages.

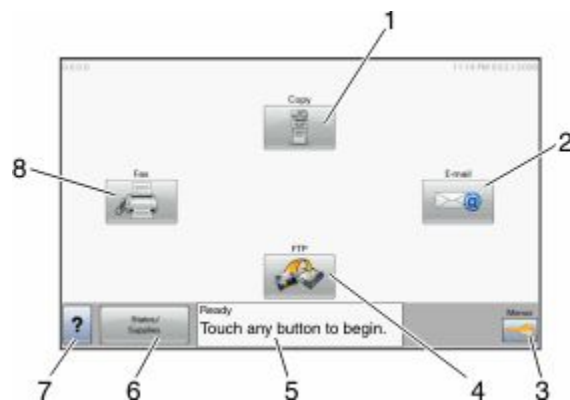

Display item		Description
1	Copy	Opens the Copy menus <b>Note:</b> From the home screen, you can also access the Copy menus by pressing a number on the keypad.
2	E-mail	Opens the E-mail menus
3	Menus	Opens the menus. These menus are available only when the printer is in the <b>Ready</b> state.

Display item		Description
4	FTP	Opens the File Transfer Protocol (FTP) menus <b>Note:</b> This function must be set up by your system support person. Once it is set up, it appears as a display item.
5	Status message bar	<ul style="list-style-type: none"> <li>Shows the current printer status such as <b>Ready</b> or <b>Busy</b>.</li> <li>Shows printer conditions such as <b>Toner Low</b>.</li> <li>Shows intervention messages to give instructions on what you should do so the printer can continue processing, such as <b>Close door</b> or <b>Insert print cartridge</b>.</li> </ul>
6	Status/Supplies	Appears on the display whenever the printer status includes a message requiring intervention. Touch it to access the messages screen for more information on the message, including how to clear it.
7	Tips	All menus have a Tips button. Tips is a context-sensitive Help feature within the display touch screens.
8	Fax	Opens the Fax menus

Other buttons that may appear on the home screen:

Display item	Function
Release Held Faxes	If this button is shown, then there are held faxes with a scheduled hold time previously set. To access the list of held faxes, touch this button.
Search Held Jobs	Searches on any of the following items and returns search results: <ul style="list-style-type: none"> <li>User names for held or confidential print jobs</li> <li>Job names for held jobs, excluding confidential print jobs</li> <li>Profile names</li> <li>Bookmark container or job names</li> <li>USB container or job names for supported extensions only</li> </ul>
Held Jobs	Opens a screen containing all the held jobs
Lock Device	This button appears on the screen when the printer is unlocked and Device Lockout Personal Identification Number (PIN) has been set. Touching this button opens a PIN entry screen. Entering the correct PIN locks the printer control panel (touch screen and hard buttons).
Unlock Device	This button appears on the screen when the printer is locked. The printer control panel buttons and shortcuts cannot be used while it appears. Touching this button opens a PIN entry screen. Entering the correct PIN unlocks the printer control panel (touch screen and hard buttons).



Display item	Function
Cancel Jobs	<p>Opens the Cancel Jobs screen. The Cancel Jobs screen shows three headings: Print, Fax, and Network.</p> <p>The following items are available under the Print, Fax, and Network headings:</p> <ul style="list-style-type: none"> <li>• Print job</li> <li>• Copy job</li> <li>• Fax profile</li> <li>• FTP</li> <li>• E-mail send</li> </ul> <p>Each heading has a list of jobs shown in a column under it which can show only three jobs per screen. Each job appears as a button which you can touch to access information about the job. If more than three jobs exist in a column, then an arrow appears enabling you to scroll through the jobs.</p>





## Using the touch-screen buttons

**Note:** Depending on your options and administrative setup, your screens and buttons may vary from those shown.



### Sample touch screen



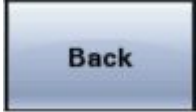





Button	Function
	Returns to the home screen
	Opens a drop-down list

Button	Function
Left scroll decrease 	Scrolls to another value in decreasing order
Right scroll increase 	Scrolls to another value in increasing order
Left arrow 	Scrolls left
Right arrow 	Scrolls right
Submit 	Saves a value as the new user default setting
Back 	Navigates back to the previous screen

## Other touch-screen buttons

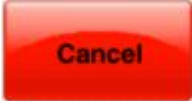
Button	Function
Down arrow 	Moves down to the next screen
Up arrow 	Moves up to the next screen

Button	Function
Unselected radio button 	This is an unselected radio button. The radio button is gray to show it is unselected.
Selected radio button 	This is a selected radio button. The radio button is blue to show it is selected.
Cancel Jobs 	Opens the Cancel Jobs screen. The Cancel Jobs screen shows three headings: Print, Fax, and Network. The following items are available under the Print, Fax, and Network headings: <ul style="list-style-type: none"> <li>• Print job</li> <li>• Copy job</li> <li>• Fax profile</li> <li>• FTP</li> <li>• E-mail send</li> </ul> Each heading has a list of jobs shown in a column under it which can show only three jobs per screen. Each job appears as a button which you can touch to access information about the job. If more than three jobs exist in a column, then an arrow appears enabling you to scroll through the jobs.
Continue 	Touch this button when more changes need to be made for a job or after clearing a paper jam.
Cancel 	<ul style="list-style-type: none"> <li>• Cancels an action or a selection</li> <li>• Cancels out of a screen and returns to the previous screen</li> </ul>
Select 	Selects a menu or menu item

## Features

Feature	Description
<p>Menu trail line: <u>Menus</u>→ <u>Settings</u>→ <u>Copy Settings</u>→ Number of Copies</p>	<p>A Menu trail line is located at the top of each menu screen. This feature acts as a trail, showing the path taken to arrive at the current menu. It gives the exact location within the menus.</p> <p>Touch any of the underlined words to return to that menu or menu item.</p> <p>The Number of Copies is not underlined since this is the current screen. If you touch an underlined word on the Number of Copies screen before the Number of Copies is set and saved, then the selection is not saved, and it does not become the user default setting.</p>
<p>Attendance message alert</p> 	<p>If an attendance message occurs which closes a function, such as copy or fax, then a solid red dot appears over the function button on the home screen. This indicates that an attendance message exists.</p>

# Additional printer setup

## Installing internal options

 **CAUTION—SHOCK HAZARD:** If you are accessing the system board or installing optional hardware or memory devices sometime after setting up the printer, then turn the printer off, and unplug the power cord from the wall outlet before continuing. If you have any other devices attached to the printer, then turn them off as well, and unplug any cables going into the printer.

You can customize your printer connectivity and memory capacity by adding optional cards. The instructions in this section explain how to install the available cards; you can also use them to locate a card for removal.

All the listed options may not be available. For more information, contact the place where you purchased the printer.

## Available internal options

- Memory cards
  - Printer memory
  - Flash memory
  - Fonts
- Firmware cards
  - Bar Code and Forms
  - IPDS and SCS/TNe
  - PrintCryption™
  - PRESCRIBE
- Printer hard disk
- Internal Solutions Ports (ISP)
  - RS-232-C Serial ISP
  - Parallel 1284-B ISP
  - MarkNet™ N8150802.11 b/g/n Wireless ISP
  - MarkNet N8130 10/100 Fiber ISP
  - MarkNet N8120 10/100/1000 Ethernet ISP
- MarkNet N8110 V-34 Fax Card



## Accessing the system board to install internal options

**Note:** This operation requires a flathead screwdriver.

**⚠ CAUTION—SHOCK HAZARD:** If you are accessing the system board or installing optional hardware or memory devices sometime after setting up the printer, then turn the printer off, and unplug the power cord from the wall outlet before continuing. If you have any other devices attached to the printer, then turn them off as well, and unplug any cables going into the printer.

- 1 Open the system board door.

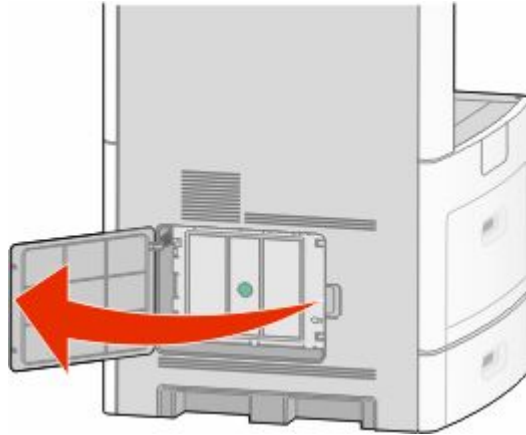

- 2 Loosen the screw(s) on the system board cover.

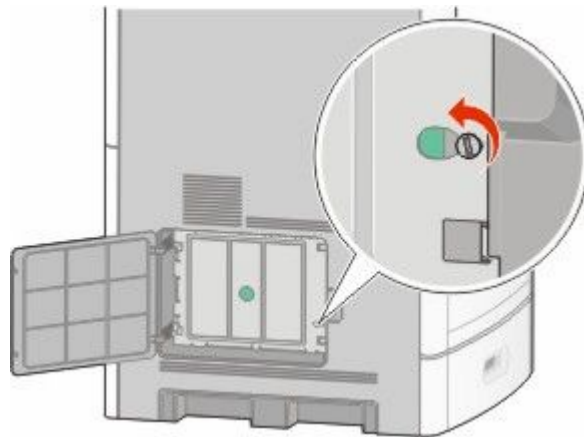

3 Remove the system board cover.

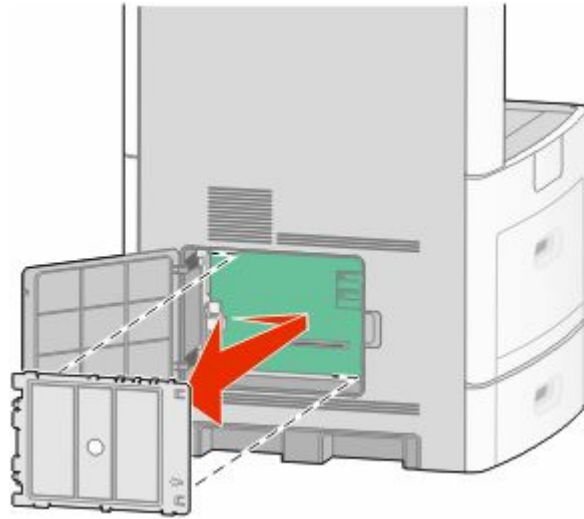

4 Use the illustration below to locate the appropriate connector.

**Warning—Potential Damage:** System board electronic components are easily damaged by static electricity. Touch something metal on the printer before touching any system board electronic components or connectors.

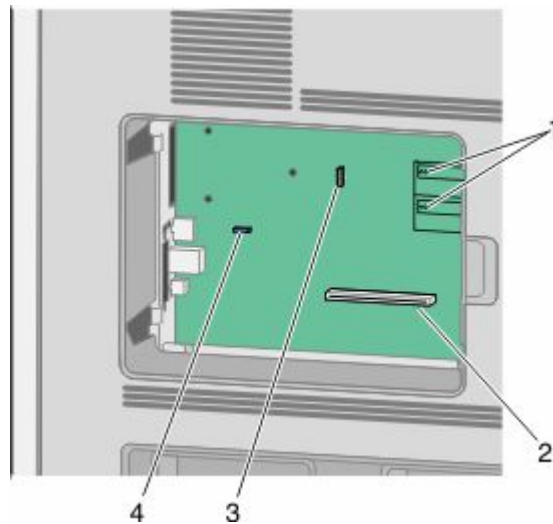

1	Firmware and flash memory card connectors
2	Memory card connector
3	Internal Solutions Port or printer hard disk connector
4	Fax card connector

# Installing a memory card

**Note:** This task requires a flathead screwdriver.

**CAUTION—SHOCK HAZARD:** If you are accessing the system board or installing optional hardware or memory devices sometime after setting up the printer, then turn the printer off, and unplug the power cord from the wall outlet before continuing. If you have any other devices attached to the printer, then turn them off as well, and unplug any cables going into the printer.

**Warning—Potential Damage:** System board electronic components are easily damaged by static electricity. Touch something metal on the printer before touching any system board electronic components or connectors.

An optional memory card can be purchased separately and attached to the system board. To install the memory card:

- 1 Access the system board.



- 2 Unpack the memory card.

**Note:** Avoid touching the connection points along the edge of the card.

- 3 Open the memory card connector latches.



4 Align the notches on the memory card with the ridges on the connector.

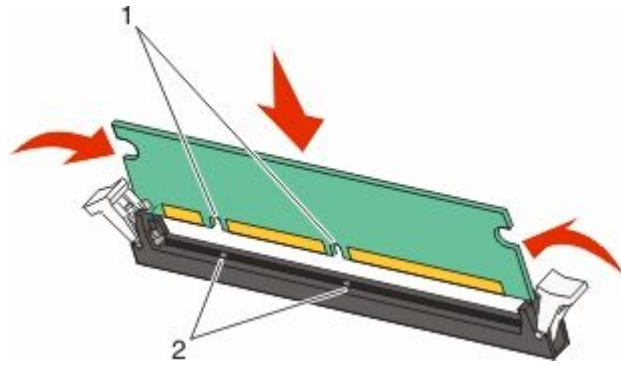

1	Notches
2	Ridges

5 Push the memory card straight into the connector until it *snaps* into place.

6 Replace the system board cover and close the system board door.

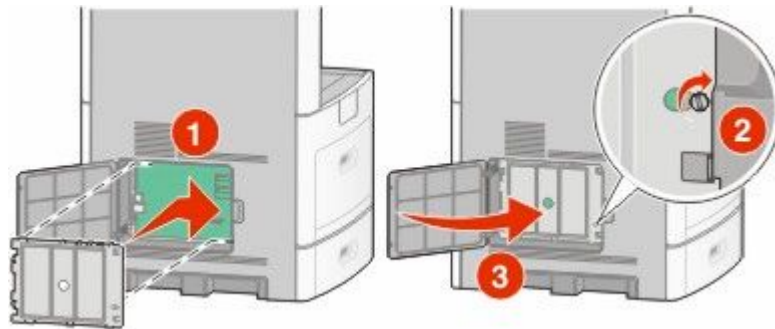

## Installing a flash memory or firmware card

**Note:** This task requires a flathead screwdriver.

The system board has two connections for an optional flash memory or firmware card. Only one of each may be installed, but the connectors are interchangeable.

**CAUTION—SHOCK HAZARD:** If you are accessing the system board or installing optional hardware or memory devices sometime after setting up the printer, then turn the printer off, and unplug the power cord from the wall outlet before continuing. If you have any other devices attached to the printer, then turn them off as well, and unplug any cables going into the printer.

**Warning—Potential Damage:** System board electronic components are easily damaged by static electricity. Touch something metal on the printer before touching any system board electronic components or connectors.

- 1 Access the system board.



- 2 Unpack the card.

**Note:** Avoid touching any electrical components on the card.

- 3 Holding the card by its sides, align the plastic pins on the card with the holes on the system board.

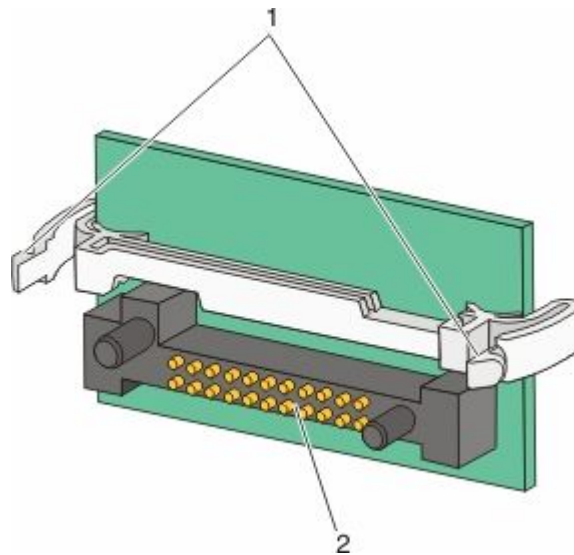

1	Plastic pins
2	Metal pins

4 Push the card firmly into place.

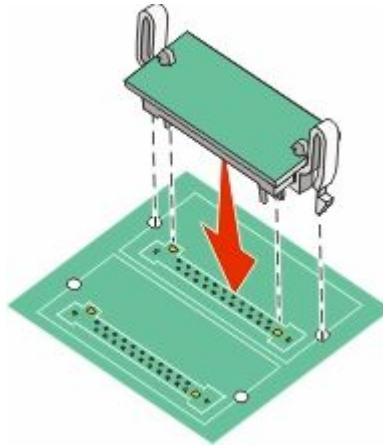

**Notes:**

- The entire length of the connector on the card must touch and be flush against the system board.
- Be careful not to damage the connectors.

5 Replace the system board cover and close the system board door.

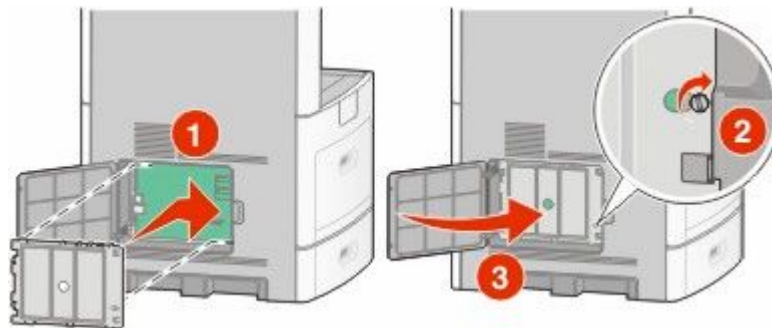

# Installing an Internal Solutions Port

The system board supports one optional Internal Solutions Port (ISP). Install an ISP for additional connectivity options.

**Note:** This operation requires a flathead screwdriver.

**CAUTION—SHOCK HAZARD:** If you are accessing the system board or installing optional hardware or memory devices sometime after setting up the printer, then turn the printer off, and unplug the power cord from the wall outlet before continuing. If you have any other devices attached to the printer, then turn them off as well, and unplug any cables going into the printer.

**Warning—Potential Damage:** System board electronic components are easily damaged by static electricity. Touch something metal on the printer before touching any system board electronic components or connectors.

- 1 Access the system board.



- 2 Unpack the ISP and plastic tee.

**Note:** Avoid touching the components on the card.

- 3 Locate the appropriate connector on the system board.

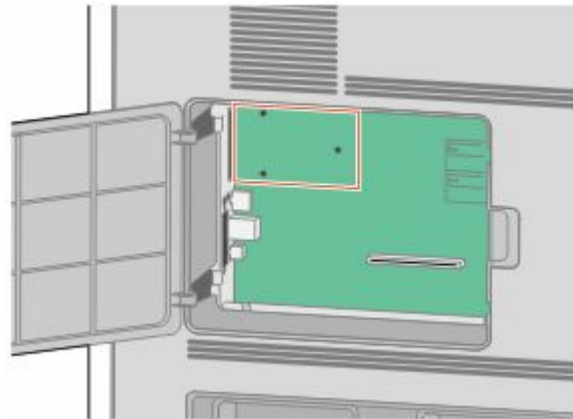

**Note:** If an optional printer hard disk is currently installed, then the printer hard disk must first be removed. To remove the hard disk:

- a** Unplug the printer hard disk interface cable from the system board, leaving the cable attached to the printer hard disk. To unplug the cable, squeeze the paddle at the plug of the interface cable to disengage the latch before pulling the cable out.

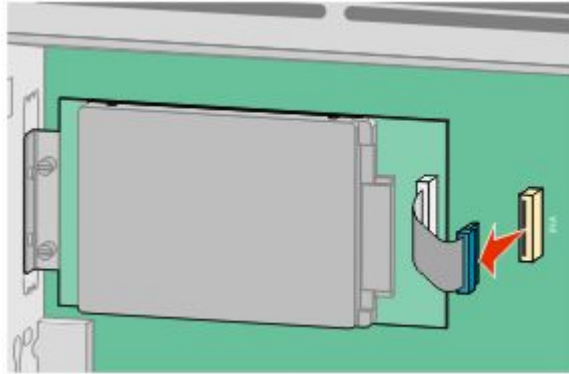

- b** Remove the screws holding the printer hard disk in place.

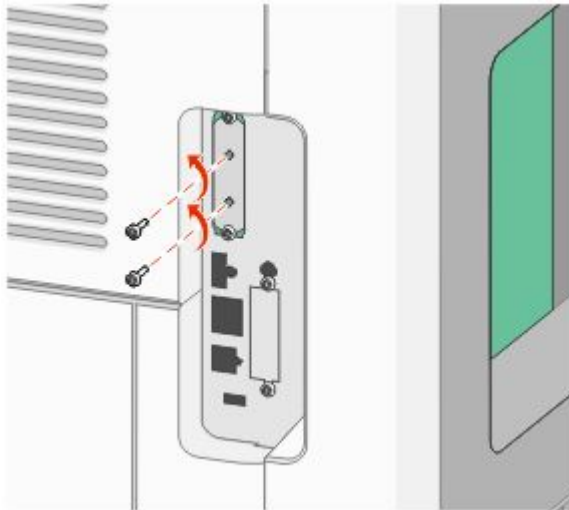

- c** Remove the printer hard disk by pulling it upward to unseat the standoffs.

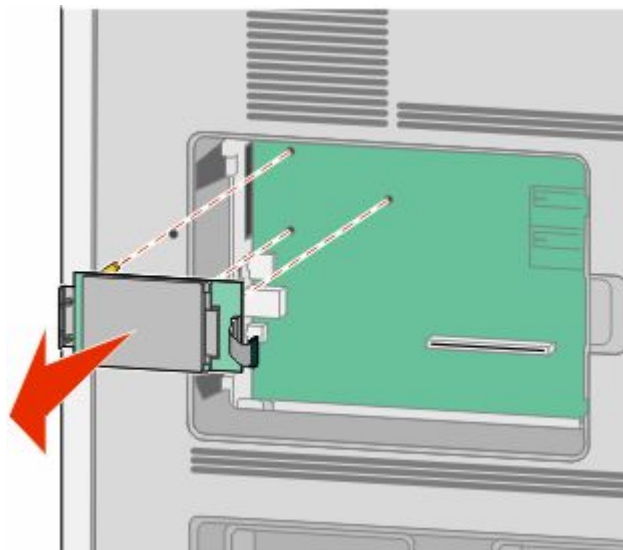



- d** Remove the thumbscrews that attach the printer hard disk mounting bracket to the printer hard disk, and then remove the bracket. Set the printer hard disk aside.

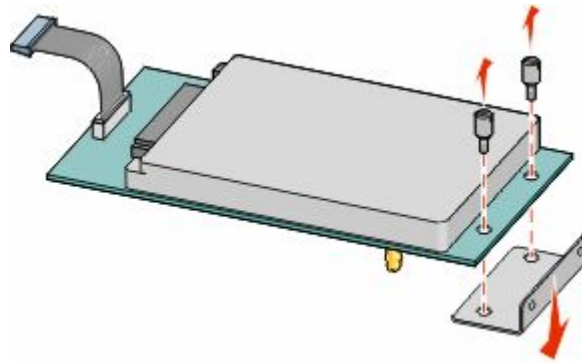

- 4** Remove the metal cover from the ISP opening.

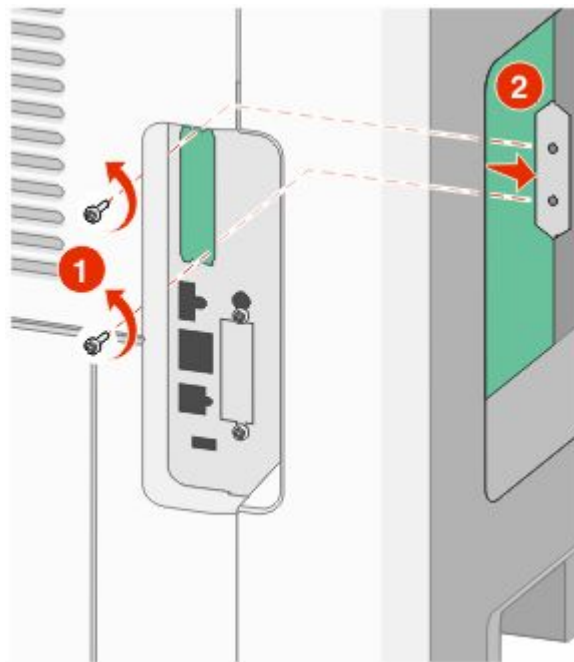

- 5** Align the posts of the plastic tee to the holes in the system board, and then press downward until the tee snaps into place. Be sure each post of the tee has latched completely, and that the tee is seated firmly onto the system board.

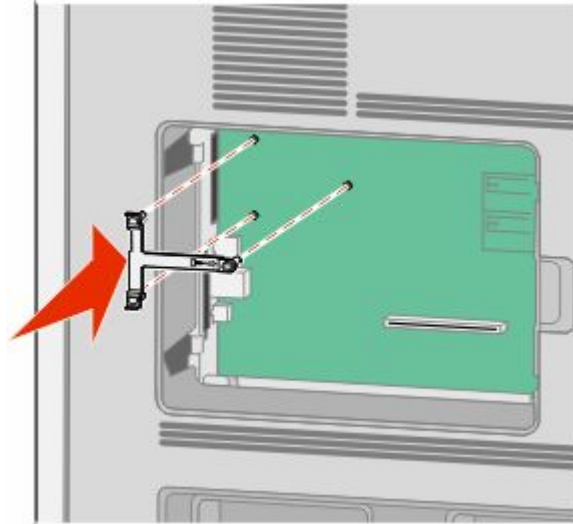

- 6** Install the ISP onto the plastic tee. Angle the ISP over the plastic tee, and then approach the plastic tee so that any overhanging connectors will pass through the ISP opening in the system board cage.



**7** Lower the ISP toward the plastic tee until the ISP is seated between the guides of the plastic tee.

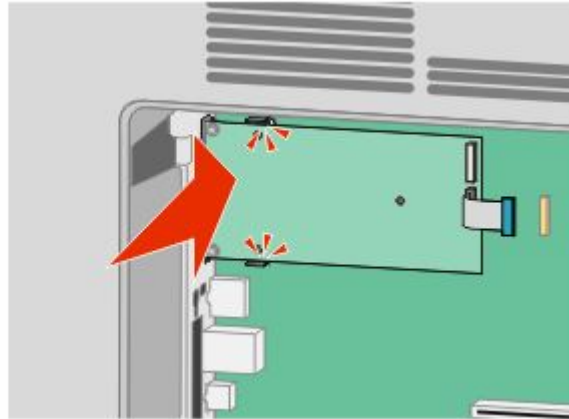

**8** Insert the long thumbscrew and turn it clockwise enough to hold the ISP in place, but do not tighten the thumbscrew at this time.

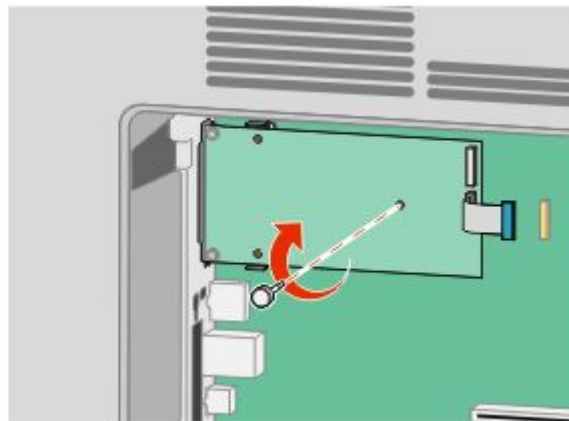

9 Attach the two provided screws to secure the ISP mounting bracket to the system board cage.

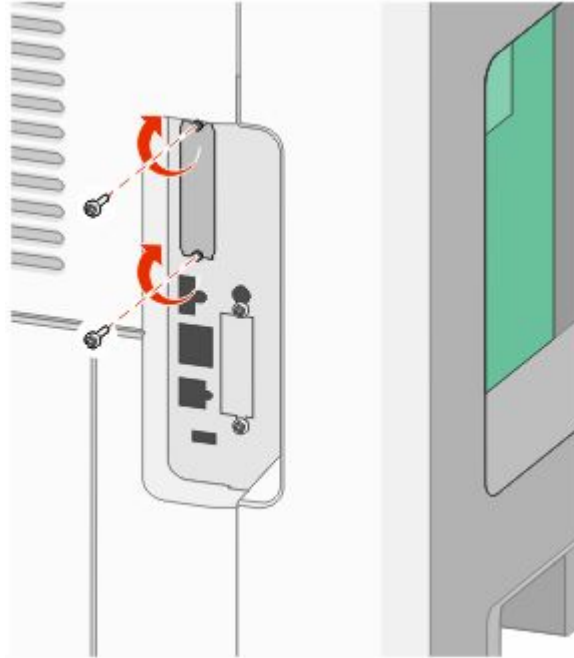

10 Tighten the long thumbscrew.

**Note:** Do not overtighten the thumbscrew.

11 Insert the plug of the ISP interface cable into the receptacle of the system board.

**Note:** The plugs and receptacles are color coded.

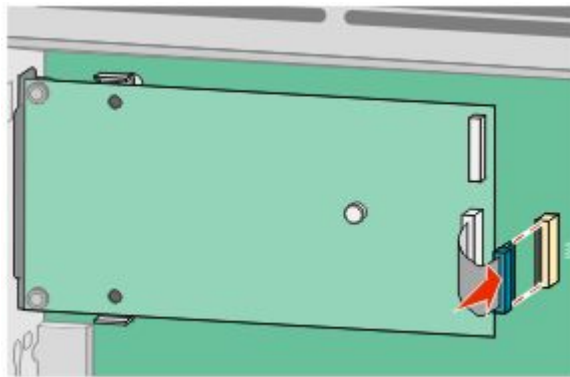

12 If a printer hard disk was previously installed, then attach the printer hard disk to the ISP. For more information, see “Installing a printer hard disk” on page 37.

13 Replace the system board cover and close the system board door.

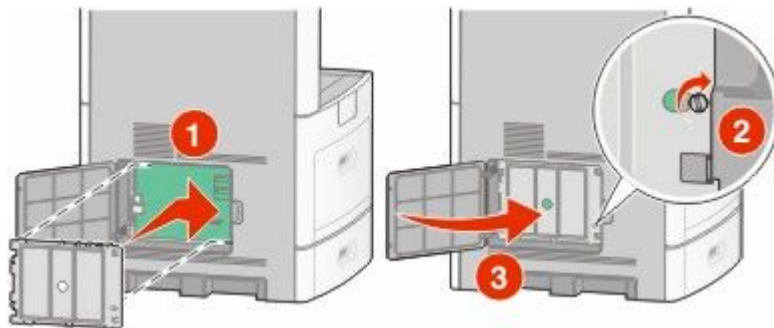

## Installing a printer hard disk

The optional printer hard disk can be installed with or without an Internal Solutions Port (ISP).

**Note:** This operation requires a flathead screwdriver.

**CAUTION—SHOCK HAZARD:** If you are accessing the system board or installing optional hardware or memory devices sometime after setting up the printer, then turn the printer off, and unplug the power cord from the wall outlet before continuing. If you have any other devices attached to the printer, then turn them off as well, and unplug any cables going into the printer.

**Warning—Potential Damage:** System board electronic components are easily damaged by static electricity. Touch something metal on the printer before touching any system board electronic components or connectors.

1 Access the system board.



2 Unpack the printer hard disk.

**Note:** Avoid touching the components on the card.

**3** Locate the appropriate connector on the system board.

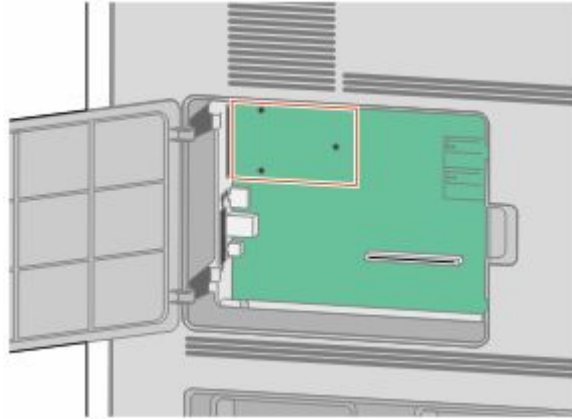

**Note:** If an optional ISP is currently installed, then the printer hard disk must be installed onto the ISP.

To install a printer hard disk onto the ISP:

- a** Using a flathead screwdriver to loosen the screws, remove the thumbscrews that attach the printer hard disk mounting bracket to the printer hard disk, and then remove the bracket.

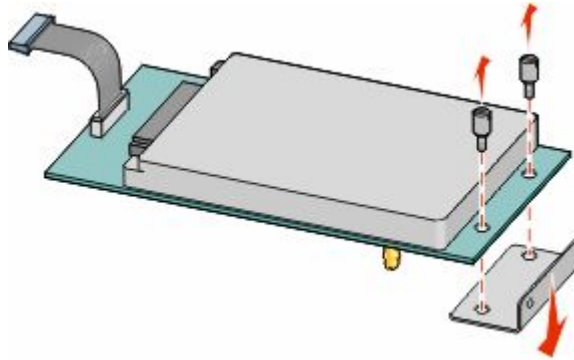

- b** Align the standoffs of the printer hard disk with the holes in the ISP, and then press downward on the printer hard disk until the standoffs have seated into place.

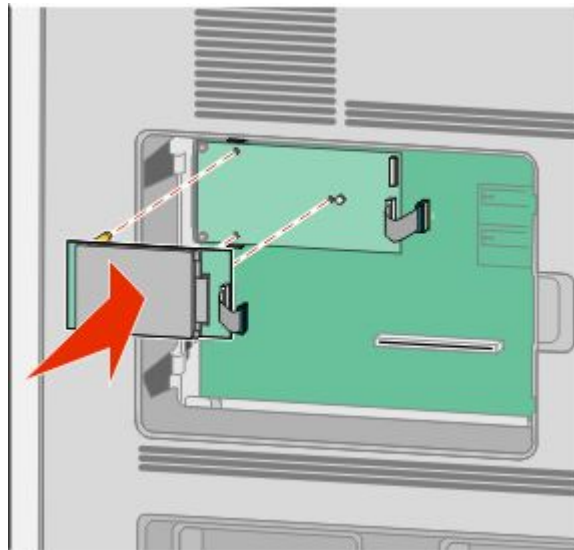

- c Insert the plug of the printer hard disk interface cable into the receptacle of the ISP.

**Note:** The plugs and receptacles are color coded.

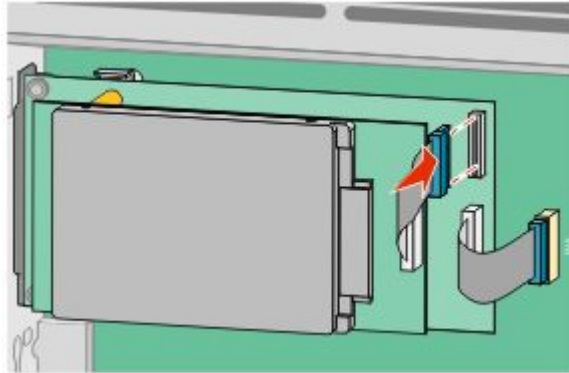

To install a printer hard disk directly onto the system board:

- a Align the standoffs of the printer hard disk with the holes in the system board, and then press downward on the printer hard disk until the standoffs have seated into place.

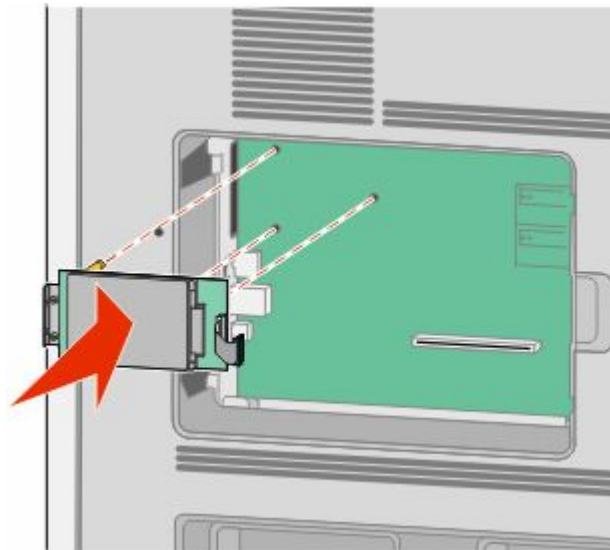

**b** Attach the two provided screws to secure the printer hard disk mounting bracket.

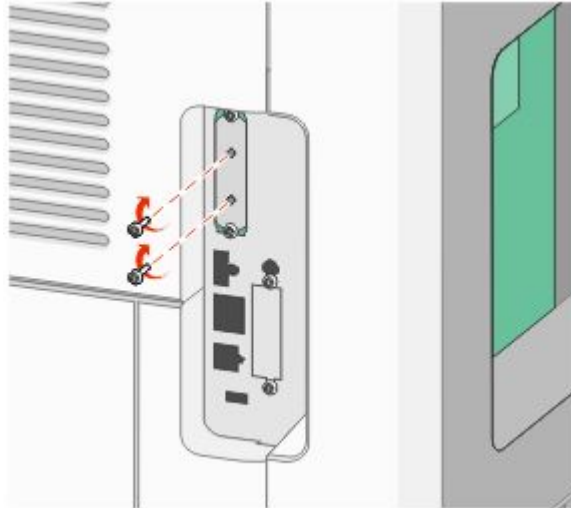

**c** Insert the plug of the printer hard disk interface cable into the receptacle of the system board.

**Note:** The plugs and receptacles are color coded.

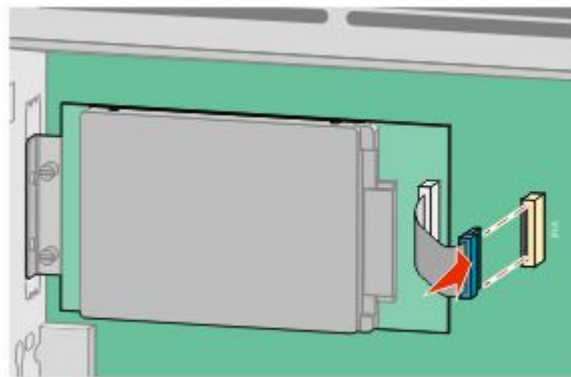

**4** Replace the system board cover and close the system board door.

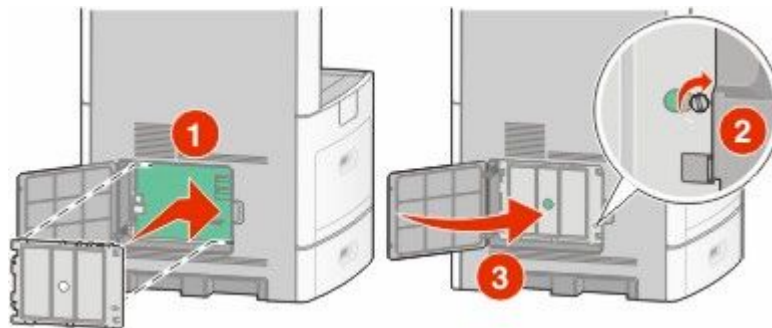



# Installing a fax card

**Note:** This task requires a flathead screwdriver.

**CAUTION—SHOCK HAZARD:** If you are accessing the system board or installing optional hardware or memory devices sometime after setting up the printer, then turn the printer off, and unplug the power cord from the wall outlet before continuing. If you have any other devices attached to the printer, then turn them off as well, and unplug any cables going into the printer.

**Warning—Potential Damage:** System board electronic components are easily damaged by static electricity. Touch something metal on the printer before touching any system board electronic components or connectors.

- 1 Access the system board.



- 2 Unpack the fax card.
- 3 Remove the metal cover from the fax card opening.

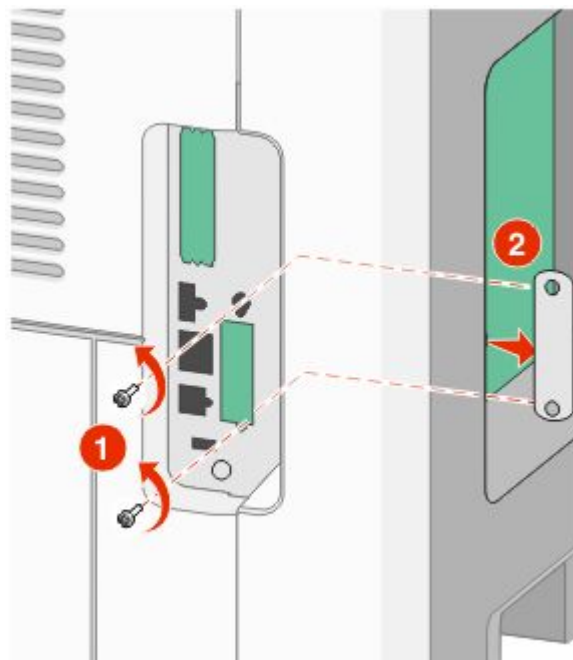

4 Insert the fax card and attach the two provided screws to secure the fax card mounting bracket.

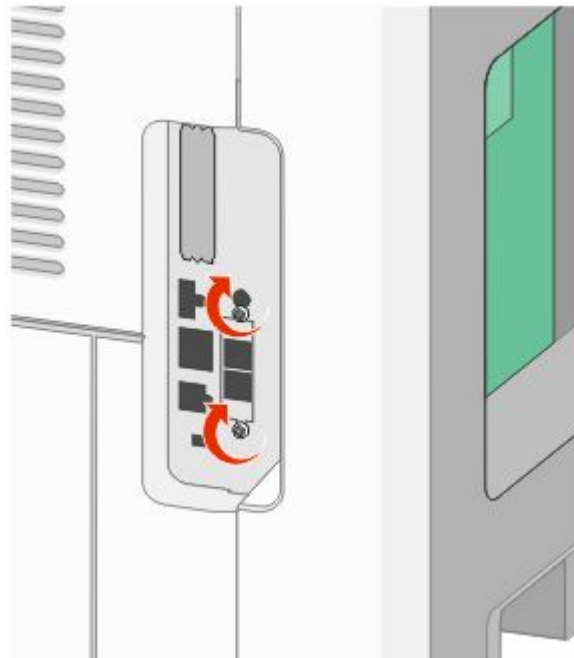
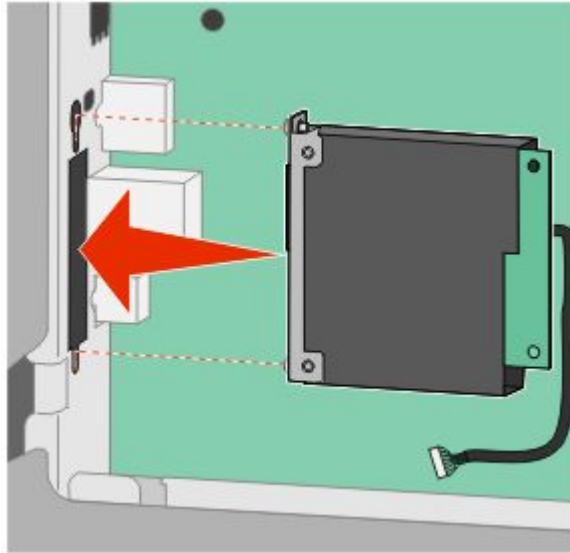

5 Insert the plug of the fax card interface cable into the receptacle of the system board.

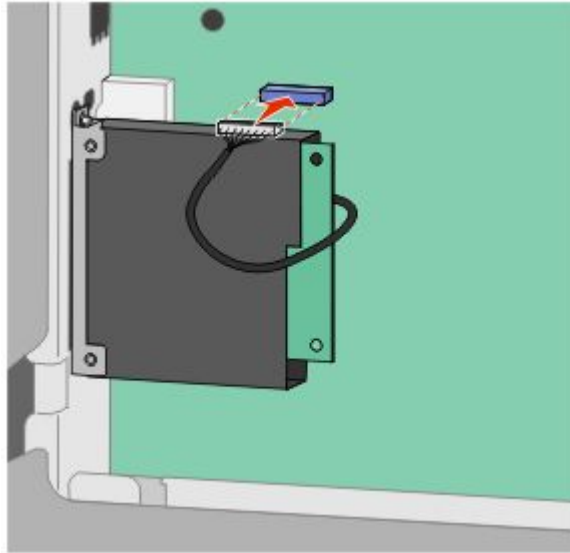

6 Replace the system board cover and close the system board door.

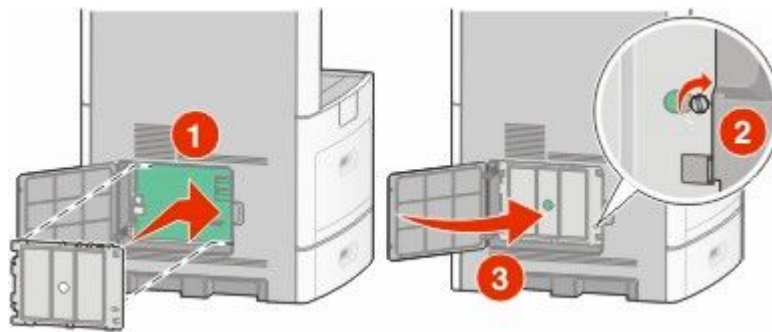

## Attaching cables

Connect the printer to the computer using a USB cable or Ethernet cable.

Be sure to match the following:

- The USB symbol on the cable with the USB symbol on the printer
- The appropriate Ethernet cable to the Ethernet port

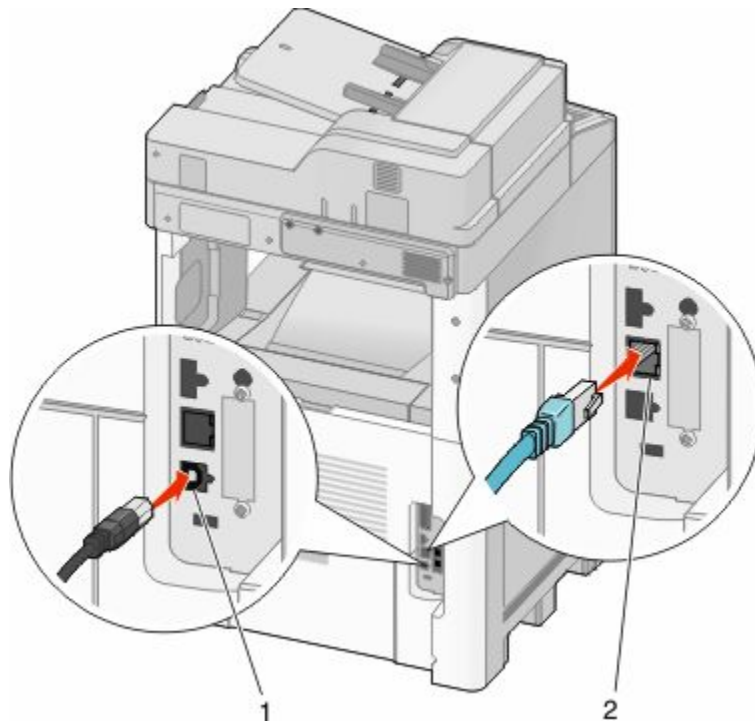

1	USB port
2	Ethernet port

## Verifying printer setup

Once all hardware and software options are installed and the printer is turned on, verify that the printer is set up correctly by printing the following:

- **Menu settings page**—Use this page to verify that all printer options are installed correctly. A list of installed options appears toward the bottom of the page. If an option you installed is not listed, then it is not installed correctly. Remove the option and install it again.
- **Network setup page**—If your printer is a network model and is attached to a network, print a network setup page to verify the network connection. This page also provides important information that aids network printing configuration.

## Printing a menu settings page

Print a menu settings page to review the current menu settings and to verify printer options are installed correctly.

**Note:** If you have not made any menu item settings changes yet, then the menu settings page lists all the factory default settings. Once you select and save other settings from the menus, they replace the factory default settings as *user default settings*. A user default setting remains in effect until you access the menu again, choose another value, and save it. To restore the factory default settings, see “Restoring the factory default settings” on page 256.

- 1 Make sure the printer is on and **Ready** appears.
- 2 On the home screen, touch .

**3** Touch **Reports**.

**4** Touch **Menu Settings Page**.

The menu settings page prints and the printer returns to the home screen.

## Printing a network setup page

If the printer is attached to a network, then print a network setup page to verify the network connection. This page also provides important information that aids network printing configuration.

**1** Make sure the printer is on and **Ready** appears.

**2** On the home screen, touch .

**3** Touch **Reports**.

**4** Touch **Network Setup Page**.

The network setup page prints and the printer returns to the home screen.

**5** Check the first section on the network setup page, and confirm that Status is "Connected."

If Status is "Not Connected," the LAN drop may not be active, or the network cable may be malfunctioning. Consult a system support person for a solution, and then print another network setup page.

## Setting up the printer software

### Installing printer software

A printer driver is software that lets the computer communicate with the printer. The printer software is typically installed during the initial printer setup. If you need to install the software after setup, follow these instructions:

#### For Windows users

- 1** Close all open software programs.
- 2** Insert the *Software and Documentation* CD.
- 3** From the main installation dialog, click **Install**.
- 4** Follow the instructions on the screen.

#### For Macintosh users

- 1** Close all open software applications.
- 2** Insert the *Software and Documentation* CD.
- 3** From the Finder desktop, double-click the printer CD icon that automatically appears.
- 4** Double-click the **Install** icon.
- 5** Follow the instructions on the screen.

# Updating available options in the printer driver

Once the printer software and any options are installed, it may be necessary to manually add the options in the printer driver to make them available for print jobs.

## For Windows users

1 Do one of the following:

### In Windows Vista

- a Click .
- b Click **Control Panel**.
- c Click **Hardware and Sound**.
- d Click **Printers**.

### In Windows XP

- a Click **Start**.
- b Click **Printers and Faxes**.

### In Windows 2000

- a Click **Start**.
- b Click **Settings → Printers**.

- 2 Select the printer.
- 3 Right-click the printer, and then select **Properties**.
- 4 Click the Install Options tab.
- 5 Under Available Options, add any installed hardware options.
- 6 Click **Apply**.

## For Macintosh users

### In Mac OS X version 10.5

- 1 From the Apple menu, choose **System Preferences**.
- 2 Click **Print & Fax**.
- 3 Select the printer, and then click **Options & Supplies**.
- 4 Click **Driver**, and then add any installed hardware options.
- 5 Click **OK**.

### In Mac OS X version 10.4 and earlier

- 1 From the Go menu, choose **Applications**.
- 2 Double-click **Utilities**, and then double-click **Print Center** or **Printer Setup Utility**.
- 3 Select the printer, and then from the Printers menu, choose **Show Info**.

- 4 From the pop-up menu, choose **Installable Options**.
- 5 Add any installed hardware options, and then click **Apply Changes**.

## Setting up wireless printing

### Information you will need to set up the printer on a wireless network

**Note:** Do not connect the installation or network cables until prompted to do so by the setup software.

- **SSID**—The SSID is also referred to as the network name.
- **Wireless Mode (or Network Mode)**—The mode will be either infrastructure or ad hoc.
- **Channel (for ad hoc networks)**—The channel defaults to auto for infrastructure networks.

Some ad hoc networks will also require the auto setting. Check with your system support person if you are not sure which channel to select.

- **Security Method**—There are three basic options for Security Method:
  - WEP key  
If your network uses more than one WEP key, enter up to four in the provided spaces. Select the key currently in use on the network by selecting the Default WEP Transmit Key.  
*or*
  - WPA or WPA2 passphrase  
WPA includes encryption as an additional layer of security. The choices are AES or TKIP. Encryption must be set for the same type on the router and on the printer, or the printer will not be able to communicate on the network.
  - No security  
If your wireless network does not use any type of security, then you will not have any security information.

**Note:** Using an unsecured wireless network is not recommended.

If you are installing the printer on an 802.1X network using the Advanced method, then you may need the following:

- Authentication type
- Inner authentication type
- 802.1X username and password
- Certificates

**Note:** For more information on configuring 802.1X security, see the *Networking Guide on the Software and Documentation CD*.

### Installing the printer on a wireless network (Windows)

Before you install the printer on a wireless network, make sure that:

- Your wireless network is set up and working properly.
- The computer you are using is connected to the same wireless network where you want to set up the printer.

1 Connect the power cable, and then turn the printer on.

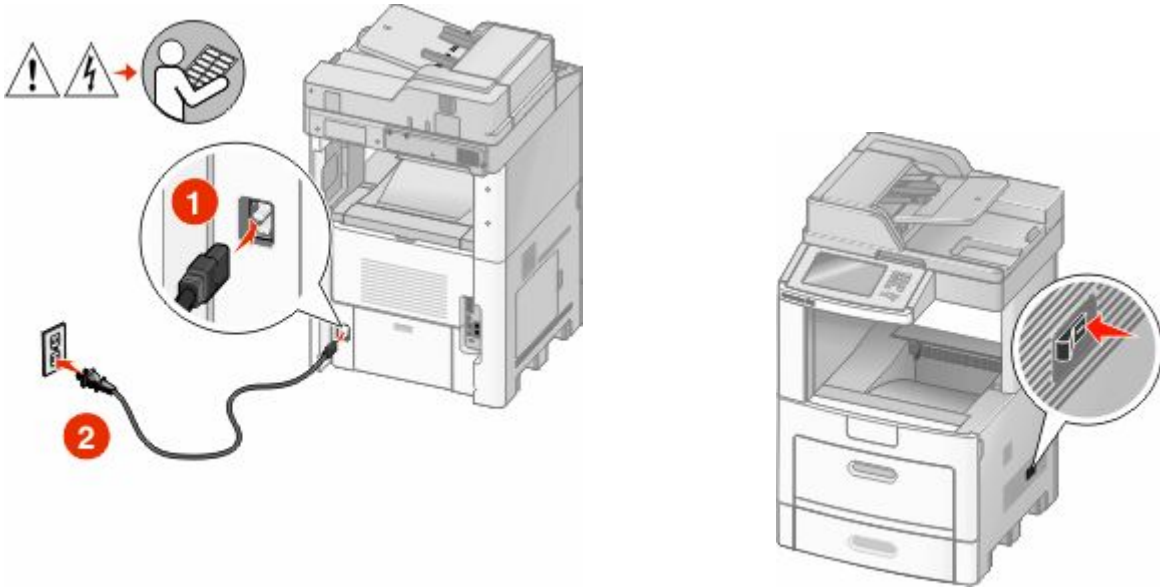

Make sure the printer and computer are fully on and ready.



Do not connect the USB cable until instructed to do so on the screen

2 Insert the *Software and Documentation* CD.

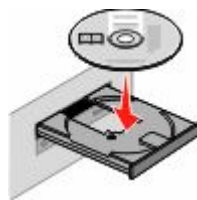

3 Click **Install**.

4 Click **Agree**.

5 Click **Suggested**.

6 Click **Wireless Network Attach**.



**7** Connect the cables in the following order:

- a** Temporarily connect a USB cable between the computer on the wireless network and the printer.

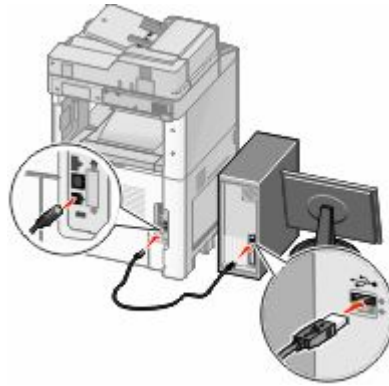

**Note:** After the printer is configured, the software will instruct you to disconnect the temporary USB cable so you can print wirelessly.

- b** If your printer has faxing capabilities, then connect the telephone cable.
- 8** Follow the on-screen instructions to complete the software installation.
- 9** To allow other computers on the wireless network to use the wireless printer, follow steps 2 through 6 and step 8 for each computer.

## Installing the printer on a wireless network (Macintosh)

### Prepare to configure the printer

**1** Locate the printer MAC address on the sheet that came with the printer. Write the last six digits of the MAC address in the space provided below:

MAC address: \_\_\_\_\_

**2** If your printer has faxing capabilities, then connect the telephone cable.

- 3 Connect the power cable, and then turn the power on.

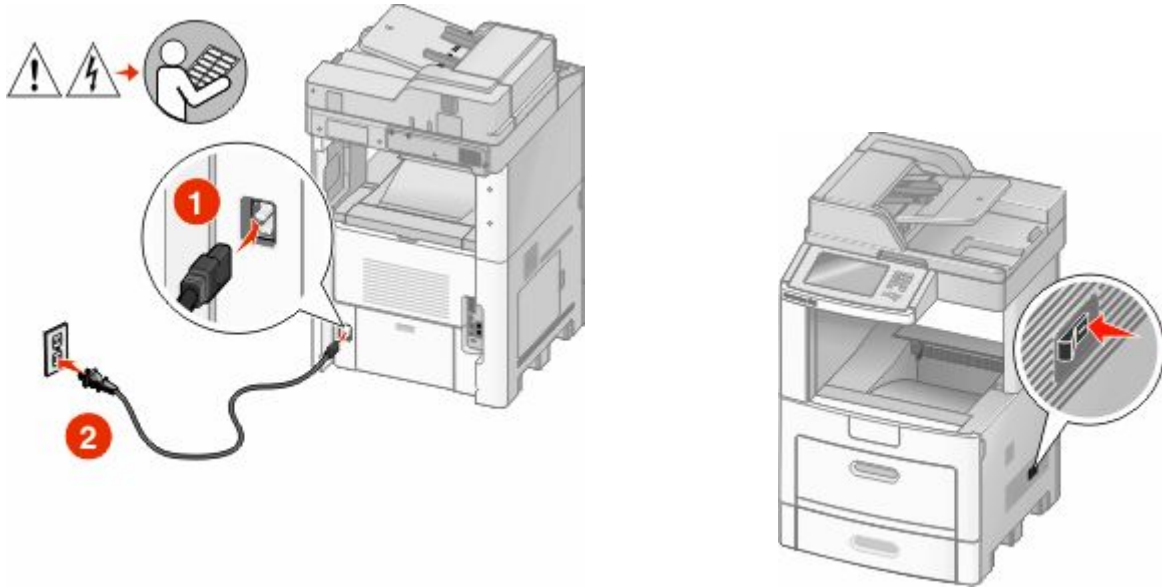

## Enter the printer information

- 1 Access the AirPort options.

### In Mac OS X version 10.5

- a From the Apple menu, choose **System Preferences**.
- b Click **Network**.
- c Click **AirPort**.

### In Mac OS X version 10.4 and earlier

- a From the Go menu, choose **Applications**.
- b Double-click **Internet Connect**.
- c From the toolbar, click **AirPort**.

- 2 From the Network pop-up menu, select **print server xxxxxx**, where the x's are the last six digits of the MAC address located on the MAC address sheet.
- 3 Open the Safari browser.
- 4 From the Bookmarks drop-down menu, select **Show**.
- 5 Under Collections, select **Bonjour** or **Rendezvous**, and then double-click the printer name.
- 6 From the main page of the Embedded Web Server, navigate to the page where the wireless settings information is stored.

## Configure the printer for wireless access

- 1 Type the name of your network (SSID) in the appropriate field.
- 2 Select **Infrastructure** as your Network Mode if you are using a wireless router.
- 3 Select the type of security you use to protect your wireless network.

- 4 Enter the security information necessary for the printer to join your wireless network.
- 5 Click **Submit**.
- 6 Open the AirPort application on your computer:

#### **In Mac OS X version 10.5**

- a From the Apple menu, choose **System Preferences**.
- b Click **Network**.
- c Click **AirPort**.

#### **In Mac OS X version 10.4 and earlier**

- a From the Go menu, choose **Applications**.
- b Double-click **Internet Connect**.
- c From the toolbar, click **AirPort**.

- 7 From the Network pop-up menu, select your wireless network.

## **Configure your computer to use the printer wirelessly**

To print to a network printer, each Macintosh user must install a custom *PostScript Printer Description* (PPD) file and create a printer in the Print Center or Printer Setup Utility.

- 1 Install a PPD file on the computer:
  - a Insert the *Software and Documentation* CD in the CD or DVD drive.
  - b Double-click the installer package for the printer.
  - c From the Welcome screen, click **Continue**.
  - d Click **Continue** again after viewing the Readme file.
  - e Click **Continue** after viewing the license agreement, and then click **Agree** to accept the terms of the agreement.
  - f Select a Destination, and then click **Continue**.
  - g From the Easy Install screen, click **Install**.
  - h Type the user password, and then click **OK**.  
All necessary software is installed on the computer.
  - i Click **Close** when installation is complete.
- 2 Add the printer:
  - a For IP printing:

#### **In Mac OS X version 10.5**

- 1 From the Apple menu, choose **System Preferences**.
- 2 Click **Print & Fax**.
- 3 Click **+**.
- 4 Select the printer from the list.
- 5 Click **Add**.

### In Mac OS X version 10.4

- 1 From the Go menu, choose **Applications**.
- 2 Double-click **Utilities**.
- 3 Locate and double-click **Printer Setup Utility** or **Print Center**.
- 4 From the Printer List, choose **Add**.
- 5 Select the printer from the list.
- 6 Click **Add**.

**b** For AppleTalk printing:

### In Mac OS X version 10.5

- 1 From the Apple menu, choose **System Preferences**.
- 2 Click **Print & Fax**.
- 3 Click **+**.
- 4 Click **AppleTalk**.
- 5 Select the printer from the list.
- 6 Click **Add**.

### In Mac OS X version 10.4

- 1 From the Go menu, choose **Applications**.
- 2 Double-click **Utilities**.
- 3 Locate and double-click **Print Center** or **Printer Setup Utility**.
- 4 From the Printer List, choose **Add**.
- 5 Choose the **Default Browser** tab.
- 6 Click **More Printers**.
- 7 From the first pop-up menu, choose **AppleTalk**.
- 8 From the second pop-up menu, select **Local AppleTalk zone**.
- 9 Select the printer from the list.
- 10 Click **Add**.

## Installing the printer on a wired network

Use the following instructions to install the printer on a wired network. These instructions apply to Ethernet and fiber optic network connections.

Before you install the printer on a wired network, make sure that:

- You have completed the initial setup of the printer.
- The printer is connected to your network with the appropriate type of cable.

### For Windows users

- 1 Insert the *Software and Documentation* CD.

Wait for the Welcome screen to appear.

If the CD does not launch after a minute, then do one of the following:

## In Windows Vista

- a Click .
- b In the Start Search box, type `D:\setup.exe`, where **D** is the letter of your CD or DVD drive.

## In Windows XP and earlier

- a Click **Start**.
- b Click **Run**.
- c Type `D:\setup.exe`, where **D** is the letter of your CD or DVD drive.

**2** Click **Install Printer and Software**.

**3** Click **Agree** to agree to the License Agreement.

**4** Select **Suggested**, and then click **Next**.

**Note:** To configure the printer using a static IP address, using IPv6, or to configure printers using scripts, select **Custom** and follow the on-screen instructions.

**5** Select **Wired Network Attach**, and then click **Next**.

**6** Select the printer manufacturer from the list.

**7** Select the printer model from the list, and then click **Next**.

**8** Select the printer from the list of printers discovered on the network, and then click **Finish**.

**Note:** If your configured printer does not appear in the list of discovered printers, click **Add Port** and follow the on-screen instructions.

**9** Follow the on-screen instructions to complete the installation.

## For Macintosh users

**1** Allow the network DHCP server to assign an IP address to the printer.

**2** Print the network setup page from the printer. For information on printing a network setup page, see "Printing a network setup page" on page 45.

**3** Locate the printer IP address in the TCP/IP section of the network setup page. You will need the IP address if you are configuring access for computers on a different subnet than the printer.

**4** Install the drivers and add the printer.

**a** Install a PPD file on the computer:

**1** Insert the *Software and Documentation* CD in the CD or DVD drive.

**2** Double-click the installer package for the printer.

**3** From the Welcome screen, click **Continue**.

**4** Click **Continue** again after viewing the Readme file.

**5** Click **Continue** after viewing the license agreement, and then click **Agree** to accept the terms of the agreement.

**6** Select a Destination, and then click **Continue**.

**7** From the Easy Install screen, click **Install**.

- 8 Type the user password, and then click **OK**.  
All the necessary software is installed on the computer.
- 9 Click **Close** when installation is complete.

**b** Add the printer:

- For IP printing:

### **In Mac OS X version 10.5**

- 1 From the Apple menu, choose **System Preferences**.
- 2 Click **Print & Fax**.
- 3 Click **+**.
- 4 Select the printer from the list.
- 5 Click **Add**.

### **In Mac OS X version 10.4 and earlier**

- 1 From the Go menu, choose **Applications**.
- 2 Double-click **Utilities**.
- 3 Double-click **Printer Setup Utility** or **Print Center**.
- 4 From the Printer List, click **Add**.
- 5 Select the printer from the list.
- 6 Click **Add**.

- For AppleTalk printing:

### **In Mac OS X version 10.5**

- 1 From the Apple menu, choose **System Preferences**.
- 2 Click **Print & Fax**.
- 3 Click **+**.
- 4 Click **AppleTalk**.
- 5 Select the printer from the list.
- 6 Click **Add**.

### **In Mac OS X version 10.4 and earlier**

- 1 From the Go menu, choose **Applications**.
- 2 Double-click **Utilities**.
- 3 Double-click **Print Center** or **Printer Setup Utility**.
- 4 From the Printer List, click **Add**.
- 5 Choose the **Default Browser** tab.
- 6 Click **More Printers**.
- 7 From the first pop-up menu, choose **AppleTalk**.
- 8 From the second pop-up menu, select **Local AppleTalk zone**.
- 9 Select the printer from the list.
- 10 Click **Add**.

**Note:** If the printer doesn't show up in the list, you may need to add it using the IP address. Contact your system support person for assistance.

# Changing port settings after installing a new network Internal Solutions Port

When a new network Internal Solutions Port (ISP) is installed in the printer, the printer configurations on computers that access the printer must be updated because the printer will be assigned a new IP address. All computers that access the printer must be updated with this new IP address in order to print to it over the network.

## Notes:

- If the printer has a static IP address that will stay the same, then you do not need to make any changes to the computer configurations.
- If the computers are configured to print to the printer by a network name that will stay the same, instead of by IP address, then you do not need to make any changes to the computer configurations.
- If you are adding a wireless ISP to a printer previously configured for a wired connection, then make sure the wired network is disconnected when you configure the printer to operate wirelessly. If the wired connection remains connected, then the wireless configuration will complete, but the wireless ISP will not be active. This can be fixed by disconnecting the wired connection, turning the printer off, and then turning the printer back on again.

## For Windows users

- 1 Print a network setup page and make a note of the new IP address.
- 2 Do one of the following:

### In Windows Vista

- a Click .
- b Click **Control Panel**.
- c Under Hardware and Sound, click **Printer**.

### In Windows XP

- a Click **Start**.
- b Click **Printers and Faxes**.

### In Windows 2000

- a Click **Start**.
- b Click **Settings → Printers**.

- 3 Locate the printer that has changed.

**Note:** If there is more than one copy of the printer, then update all of them with the new IP address.

- 4 Right-click the printer.
- 5 Click **Properties**.
- 6 Click the **Ports** tab.
- 7 Locate the port in the list, and then select it.
- 8 Click **Configure Port**.

- 9 Type the new IP address in the "Printer Name or IP Address" field. You can find the new IP address on the network setup page you printed in step 1.
- 10 Click **OK**, and then click **Close**.

## For Mac users

- 1 Print a network setup page and make a note of the new IP address.
- 2 Locate the printer IP address in the TCP/IP section of the network setup page. You will need the IP address if you are configuring access for computers on a different subnet than the printer.
- 3 Add the printer:
  - For IP printing:

### In Mac OS X version 10.5

- a From the Apple menu, choose **System Preferences**.
- b Click **Print & Fax**.
- c Click **+**.
- d Select the printer from the list.
- e Click **Add**.

### In Mac OS X version 10.4 and earlier

- a From the Go menu, choose **Applications**.
  - b Double-click **Utilities**.
  - c Double-click **Printer Setup Utility** or **Print Center**.
  - d From the Printer List, click **Add**.
  - e Select the printer from the list.
  - f Click **Add**.
- For AppleTalk printing:

### In Mac OS X version 10.5

- a From the Apple menu, choose **System Preferences**.
- b Click **Print & Fax**.
- c Click **+**.
- d Click **AppleTalk**.
- e Select the printer from the list.
- f Click **Add**.

### In Mac OS X version 10.4 and earlier

- a From the Go menu, choose **Applications**.
- b Double-click **Utilities**.
- c Double-click **Print Center** or **Printer Setup Utility**.
- d From the Printer List, click **Add**.
- e Choose the **Default Browser** tab.
- f Click **More Printers**.
- g From the first pop-up menu, choose **AppleTalk**.



- h** From the second pop-up menu, select **Local AppleTalk zone**.
- i** Select the printer from the list.
- j** Click **Add**.

## Setting up serial printing

In serial printing, data is transferred one bit at a time. Although serial printing is usually slower than parallel printing, it is the preferred option when there is a great deal of distance between the printer and computer or when an interface with a better transfer rate is not available.

After installing the serial port, you will need to configure the printer and the computer so they can communicate. Make sure you have connected the serial cable to the serial port on your printer.

- 1** Set the parameters in the printer:
  - a** From the printer control panel, navigate to the menu with port settings.
  - b** Locate the submenu with serial port settings.
  - c** Make any necessary changes to the serial settings.
  - d** Save the new settings.
  - e** Print a menu settings page.
- 2** Install the printer driver:
  - a** Insert the *Software and Documentation CD*. It launches automatically. If the CD does not launch automatically, do one of the following:

### In Windows Vista

- 1** Click .
- 2** In the Start Search box, type `D:\setup.exe`, where **D** is the letter of your CD or DVD drive.

### In Windows XP and earlier

- 1** Click **Start**.
  - 2** Click **Run**.
  - 3** Type `D:\setup.exe`, where **D** is the letter of your CD or DVD drive.
- b** Click **Install Printer and Software**.
  - c** Click **Agree** to accept the Printer Software License Agreement.
  - d** Click **Custom**.
  - e** Make sure **Select Components** is selected, and then click **Next**.
  - f** Make sure **Local** is selected, and then click **Next**.
  - g** Select the manufacturer of the printer from the menu.
  - h** Select the printer model from the menu, and then click **Add Printer**.
  - i** Click the **+** beside the printer model under **Select Components**.
  - j** Make sure the correct port is available under **Select Components**. This is the port where the serial cable attaches to the computer. If the correct port is not available, select the port under the **Select Port** menu, and then click **Add Port**.

- k** Make any configuration changes necessary in the Add a New Port window. Click **Add Port** to finish adding the port.
- l** Make sure the box next to the selected printer model is checked.
- m** Select any other optional software you want to install, and then click **Next**.
- n** Click **Finish** to complete the printer software installation.

**3** Set the COM port parameters:

After the printer driver is installed, you must set the serial parameters in the communications (COM) port assigned to the printer driver.

The serial parameters in the COM port must match the serial parameters you set in the printer.

- a** Open the Device Manager. Do one of the following:

## In Windows Vista

- 1** Click .
- 2** Click **Control Panel**.
- 3** Click **System and Maintenance**.
- 4** Click **System**.
- 5** Click **Device Manager**.

## In Windows XP

- 1** Click **Start**.
- 2** Click **Control Panel**.
- 3** Click **Performance and Maintenance**.
- 4** Click **System**.
- 5** From the Hardware tab, click **Device Manager**.

## In Windows 2000

- 1** Click **Start**.
  - 2** Click **Settings → Control Panel**.
  - 3** Click **System**.
  - 4** From the Hardware tab, click **Device Manager**.
- b** Click **+** to expand the list of available ports.
  - c** Select the communications port where you attached the serial cable to your computer (example: COM1).
  - d** Click **Properties**.
  - e** On the Port Settings tab, set the serial parameters to the same serial parameters in the printer.  
Look for the printer settings under the serial heading on the Menu Settings page you printed earlier.
  - f** Click **OK**, and then close all the windows.
  - g** Print a test page to verify printer installation. When a test page prints successfully, printer setup is complete.

# Setting up the printer to fax

**Note:** Fax capabilities may not be available on all printer models.

The following connection methods may not be applicable in all countries or regions.



**CAUTION—SHOCK HAZARD:** Do not use the fax feature during a lightning storm. Do not set up this product or make any electrical or cabling connections, such as the fax feature, power cord, or telephone, during a lightning storm.

## Choosing a fax connection

You can connect the printer with equipment such as a telephone, an answering machine, or a computer modem.

**Note:** The printer is an analog device that works best when directly connected to the wall jack. Other devices (such as a telephone or answering machine) can be successfully attached to pass through the printer, as described in the setup steps. If you want a digital connection such as ISDN, DSL, or ADSL, a third-party device (such as a DSL filter) is required.

You *do not* need to attach the printer to a computer, but you *do* need to connect it to a telephone line to send and receive faxes.

You can connect the printer to other equipment. See the following table to determine the best way to set up the printer.

Equipment	Benefits
<ul style="list-style-type: none"><li>• The printer</li><li>• A telephone cord</li></ul>	Send and receive faxes without using a computer.
<ul style="list-style-type: none"><li>• The printer</li><li>• A telephone</li><li>• Two telephone cords</li></ul>	<ul style="list-style-type: none"><li>• Use the fax line as a normal telephone line.</li><li>• Send and receive faxes without using a computer.</li></ul>
<ul style="list-style-type: none"><li>• The printer</li><li>• A telephone</li><li>• An answering machine</li><li>• Three telephone cords</li></ul>	Receive both incoming voice messages and faxes.
<ul style="list-style-type: none"><li>• The printer</li><li>• A telephone</li><li>• A computer modem</li><li>• Three telephone cords</li></ul>	Send faxes using the computer or the printer.

# Using an RJ11 adapter

## Country/region

- United Kingdom
- Ireland
- Finland
- Norway
- Denmark
- Italy
- Sweden
- Netherlands
- France
- Portugal

To connect your printer to an answering machine, telephone, or other telecommunications equipment, use the telephone line adapter included in the box with the printer in some countries or regions.

**Note:** If you have DSL, do not connect the printer using a splitter because the fax feature may not work correctly.

- 1 Connect the adapter to the telephone cord that came with the printer.

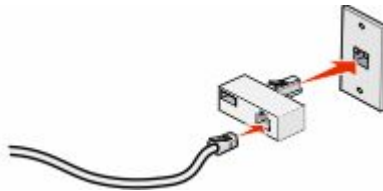

**Note:** The UK adapter is shown. Your adapter may look different, but it will fit the telephone outlet used in your location.

- 2 Connect the telephone line of your chosen telecommunications equipment to the left outlet of the adapter.



If your telecommunications equipment uses a US-style (RJ11) telephone line, follow these steps to connect the equipment:

- 1 Remove the plug from the EXT port  on the back of the printer.

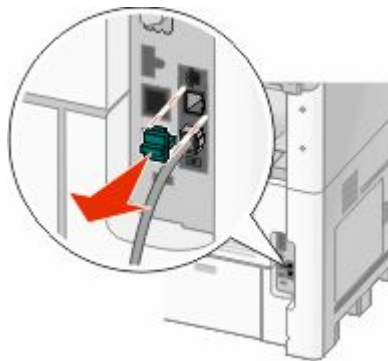

**Note:** Once this plug is removed, any country- or region-specific equipment you connect to the printer by way of the adapter, as shown, will not function properly.



2 Connect your telecommunications equipment directly to the EXT port  on the back of the printer.



**Warning—Potential Damage:** Do not touch cables or the printer in the area shown while actively sending or receiving a fax.





#### Country/region

- Saudi Arabia
- United Arab Emirates
- Egypt
- Bulgaria
- Czech Republic
- Belgium
- Australia
- South Africa
- Greece
- Israel
- Hungary
- Poland
- Romania
- Russia
- Slovenia
- Spain
- Turkey

To connect a telephone, an answering machine, or other telecommunications equipment to the printer:

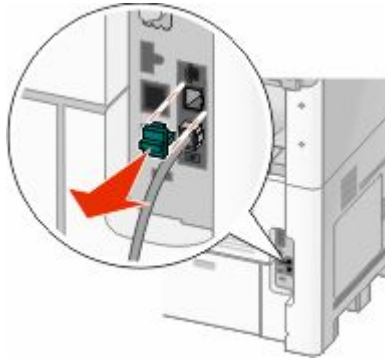
- 1 Remove the plug from the back of the printer.



- 2 Connect your telecommunications equipment directly to the EXT port  on the back of the printer.



**Note:** Once this plug is removed, any country- or region-specific equipment that you connect to the printer by way of the adapter, as shown, will not function properly.



**Country/region**

- Germany
- Austria
- Switzerland

There is a plug installed in the EXT port  of the printer. This plug is necessary for the proper functioning of the printer.



**Note:** Do not remove the plug. If you remove it, other telecommunications devices in your home (such as telephones or answering machines) may not work.

## Connecting directly to a telephone wall jack in Germany

Connect the printer directly to a telephone wall jack to send and receive faxes without using a computer.

**Note:** In Germany (and some other countries), the printer ships with a special RJ-11 plug in the EXT port. Do not remove the RJ-11 plug. It is required for both the fax and telephone to work properly.

- 1 Make sure you have a telephone cord (provided with the product) and a telephone wall jack.
- 2 Connect one end of the telephone cord into the LINE port of the printer.

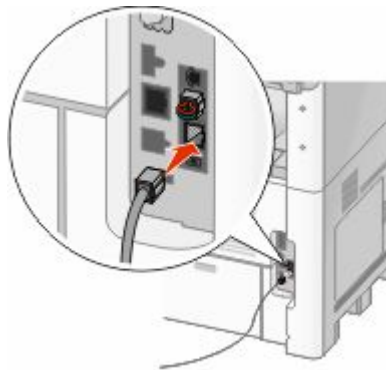

- 3 Connect the other end of the telephone cord into the N slot of an active telephone wall jack.



- 4 If you would like to use the same line for both fax and telephone communication, connect a second telephone line (not provided) between the telephone and the F slot of an active telephone wall jack.

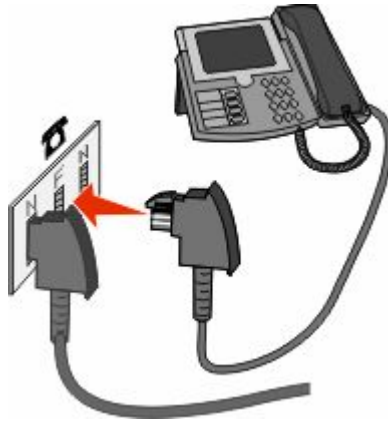

- 5 If you would like to use the same line for recording messages on your answering machine, connect a second telephone line (not provided) between the answering machine and the other N slot of the telephone wall jack.

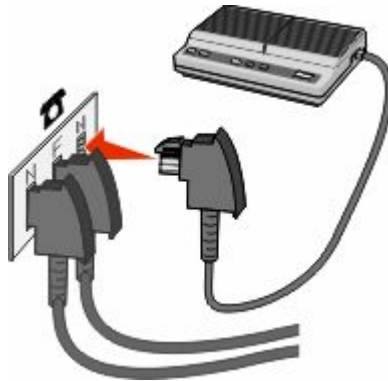

## Connecting to a telephone

Connect a telephone to the printer to use the fax line as a normal telephone line. Then set up the printer wherever your telephone is located to make copies or to send and receive faxes without using a computer.

**Note:** Setup steps may vary depending on your country or region.

- 1 Make sure you have the following:
- A telephone
  - Two telephone cords
  - A telephone wall jack



2 Connect one telephone cord to the LINE port  of the printer, and then plug it into an active telephone wall jack.



3 Remove the protective plug from the EXT port  of the printer.

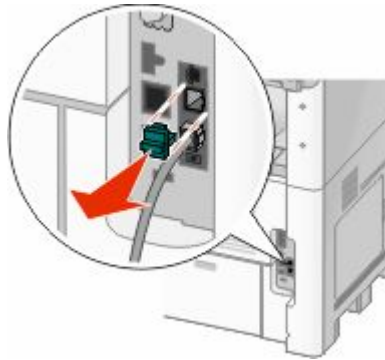

4 Connect the other telephone cord to a telephone, and then plug it into the EXT port  of the printer.



## Connecting to an answering machine

Connect an answering machine to the printer to receive both incoming voice messages and faxes.

**Note:** Setup steps may vary depending on your country or region.

1 Make sure you have the following:

- A telephone
- An answering machine
- Three telephone cords
- A telephone wall jack

- 2** Connect one telephone cord into the LINE port  of the printer, and then plug it into an active telephone wall jack.



- 3** Remove the protective plug from the EXT port  of the printer.

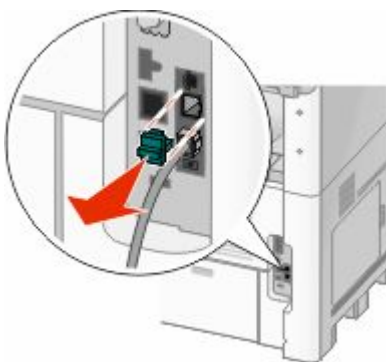

- 4** Connect a second telephone cord from the telephone to the answering machine.



- 5** Connect a third telephone cord from the answering machine to the EXT port  of the printer.



## Connecting to a computer with a modem

Connect the printer to a computer with a modem to send faxes from the software program.

**Note:** Setup steps may vary depending on your country or region.

**1** Make sure you have the following:

- A telephone
- A computer with a modem
- Three telephone cords
- A telephone wall jack

**2** Connect a telephone cord into the LINE  port of the printer, and then plug it into an active telephone wall jack.



**3** Remove the protective plug from the EXT port  of the printer.

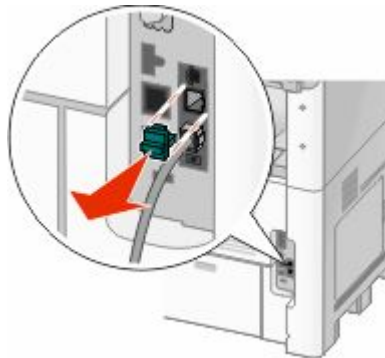

**4** Connect a second telephone cord from the telephone to the computer modem.



Additional printer setup

- 5 Connect a third telephone cord from the computer modem to the EXT port  of the printer.

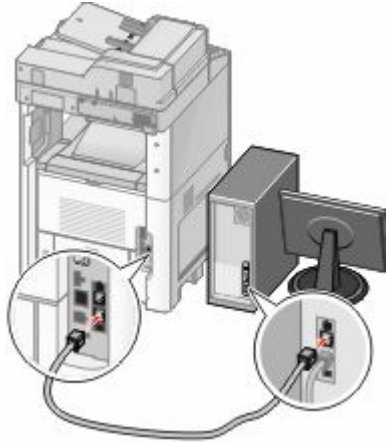

## Setting the outgoing fax name and number

To have the designated fax name and fax number printed on outgoing faxes:

- 1 Type the printer IP address into the address field of your Web browser.  
**Note:** If you do not know the IP address of the printer, then print a network setup page and locate the IP address in the TCP/IP section.
- 2 Click **Settings**.
- 3 Click **Fax Settings**.
- 4 Click **Analog Fax Setup**.
- 5 Click inside the Station Name box, and then enter the name to be printed on all outgoing faxes.
- 6 Click inside the Station Number box, and then enter the printer fax number.
- 7 Click **Submit**.

## Setting the date and time

You can set the date and time so that they are printed on every fax you send. If there is a power failure, then you may have to reset the date and time. To set the date and time:

- 1 Type the printer IP address into the address field of your Web browser.  
**Note:** If you do not know the IP address of the printer, then print a network setup page and locate the IP address in the TCP/IP section.
- 2 Click **Links & Index**.
- 3 Click **Set Date and Time**.
- 4 Click inside the Manually Set Date & Time box, and then enter the current date and time.
- 5 Click **Submit**.

## Turning Daylight Saving Time on

The printer can be set to automatically adjust for Daylight Saving Time (DST):

**1** Type the printer IP address into the address field of your Web browser.

**Note:** If you do not know the IP address of the printer, then print a network setup page and locate the IP address in the TCP/IP section.

**2** Click **Links & Index**.

**3** Click **Set Date and Time**.

**4** Select **Automatically Observe DST**.



**5** Click **Submit**.

# Loading paper and specialty media

This section explains how to load the 250-, 500-, and 2000-sheet trays, and the multipurpose feeder. It also includes information about paper orientation, setting the Paper Size and Paper Type, and linking and unlinking trays.

## Setting the Paper Size and Paper Type

The Paper Size setting is determined by the position of the paper guides in the tray for all trays except the multipurpose feeder. The Paper Size setting for the multipurpose feeder must be set manually. The factory default Paper Type setting is Plain Paper. The Paper Type setting must be set manually for all trays that do not contain plain paper.

- 1 Make sure the printer is on and **Ready** appears.
- 2 On the home screen, touch .
- 3 Touch **Paper Menu**.
- 4 Touch **Paper Size/Type**.
- 5 Touch the arrows for the desired tray until the correct size or type setting appears.
- 6 Touch **Submit**.
- 7 Touch  to return to the home screen.

## Configuring Universal paper settings

The Universal Paper Size is a user-defined setting that lets you print on paper sizes that are not preset in the printer menus. Set the Paper Size for the specified tray to Universal when the size you want is not available from the Paper Size menu. Then, specify all of the following Universal size settings for your paper:

- Units of measure (millimeters or inches)
- Portrait Width
- Portrait Height

**Note:** The smallest supported Universal size is 76 x 76 mm (3 x 3 in.); the largest size is 216 x 356 mm (8.5 x 14 in.).

### Specify a unit of measurement

- 1 Make sure the printer is on and **Ready** appears.
- 2 On the home screen, touch .
- 3 Touch **Paper Menu**.
- 4 Touch the down arrow until **Universal Setup** appears, and then touch **Universal Setup**.
- 5 Touch the left or right arrow to select the desired unit of measure.
- 6 Touch **Portrait Width** or **Portrait Height**.
- 7 Touch the arrows to select the desired width or height.

8 Touch **Submit** to save your selection.

**Submitting Selection** appears, followed by the Paper menu.

9 Touch  to return to the home screen.

## Loading the standard or optional 250-sheet or 550-sheet tray

Although the 250-sheet tray and the 550-sheet tray are different in appearance, they require the same process for loading paper. Use these instructions to load paper in either tray:

1 Pull the tray out.

**Note:** Do not remove trays while a job prints or while **Busy** appears on the display. Doing so may cause a jam.

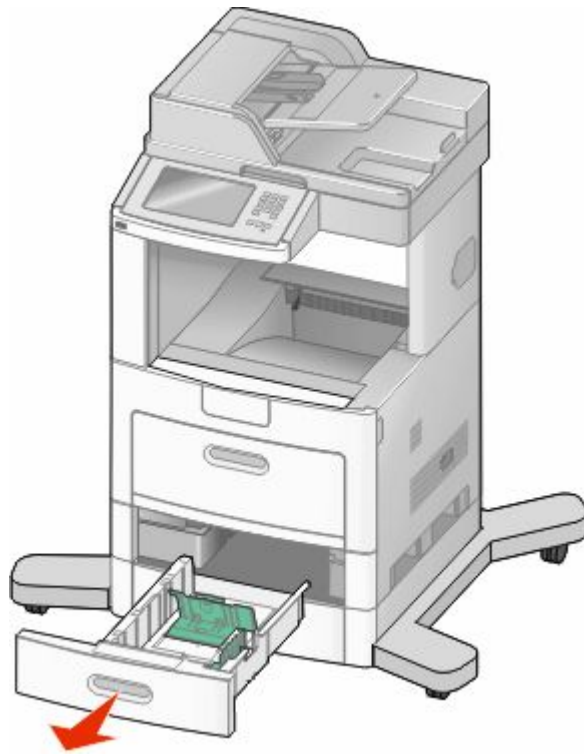

2 Squeeze the width guide tab inward as shown, and move the width guide to the correct position for the paper size being loaded.

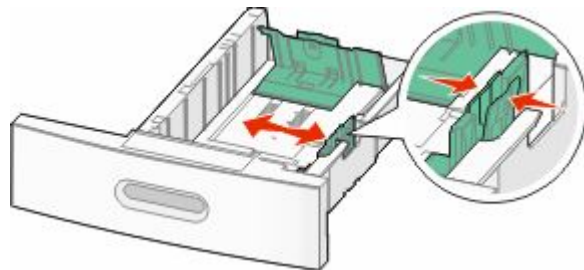

- 3 Unlock the length guide, squeeze the length guide tab inward as shown, and slide the guide to the correct position for the paper size being loaded.

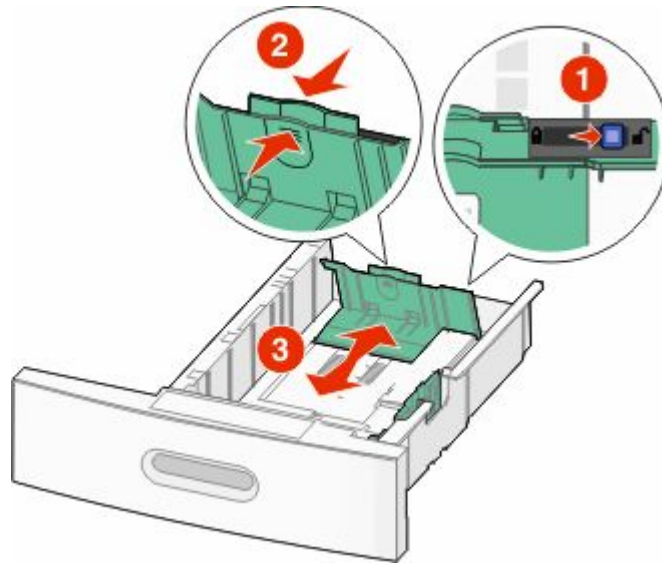

**Notes:**

- Use the size indicators on the bottom of the tray to help position the guides.
- For standard paper sizes, lock the length guide.

- 4 Flex the sheets back and forth to loosen them, and then fan them. Do not fold or crease the paper. Straighten the edges on a level surface.



- 5 Load the paper stack:

- Print side facedown for single-sided printing
- Print side faceup for duplex printing

**Note:** Paper must be loaded differently in the trays if an optional StapleSmart™ II Finisher is installed.

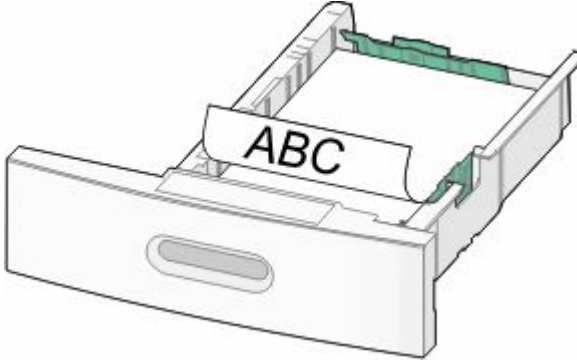
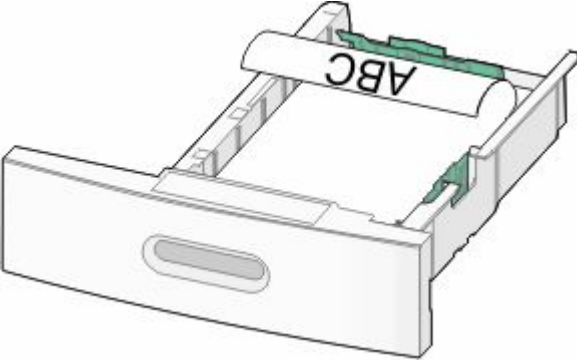
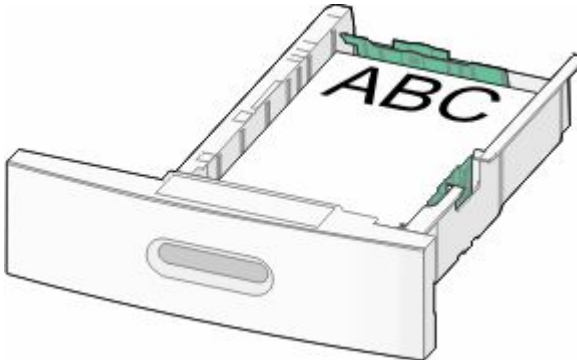
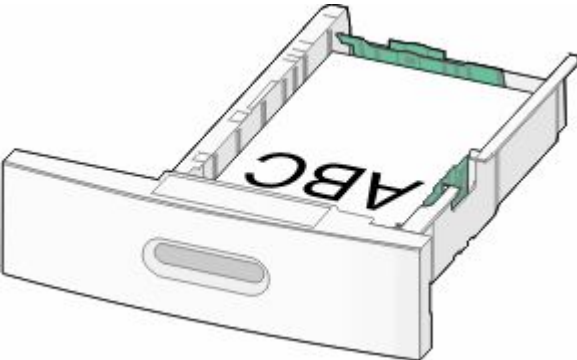

Without an optional StapleSmart II Finisher	With an optional StapleSmart II Finisher
 <p data-bbox="191 577 427 611">Single-sided printing</p>	 <p data-bbox="787 577 1023 611">Single-sided printing</p>
 <p data-bbox="191 997 503 1031">Duplex (two-sided) printing</p>	 <p data-bbox="787 997 1099 1031">Duplex (two-sided) printing</p>

**Note:** Notice the maximum fill line on the side of the tray which indicates the maximum height for loading paper. Do not overload the tray.

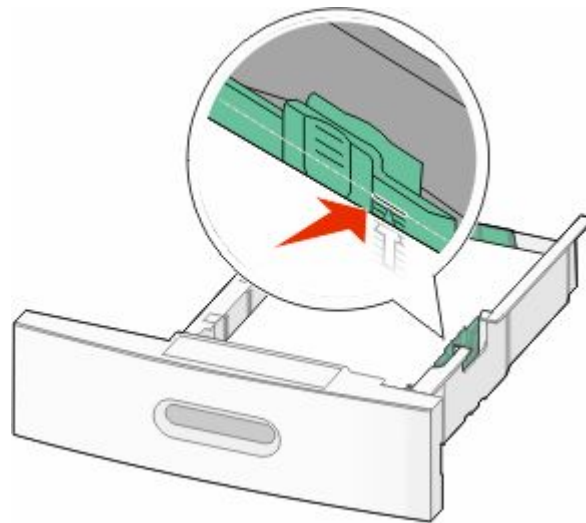

- 6 If necessary, adjust the paper guides to lightly touch the sides of the stack, and lock the length guide for the paper sizes indicated on the tray.

**7** Insert the tray.



**8** If a different type of paper was loaded than the type previously loaded in the tray, then change the Paper Type setting for the tray from the printer control panel.

## Loading the 2000-sheet tray

**1** Pull the tray out.

**2** Pull up and slide the width guide to the correct position for the paper size being loaded.

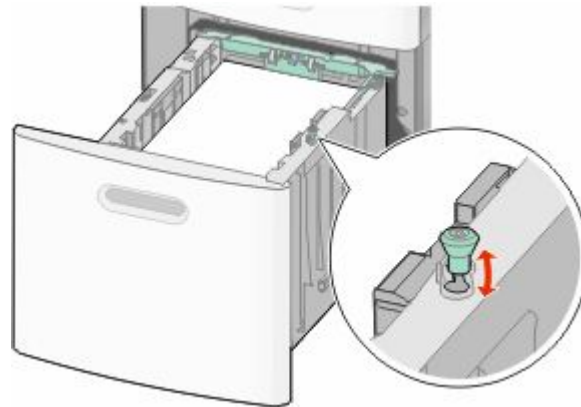

**3** Unlock the length guide.

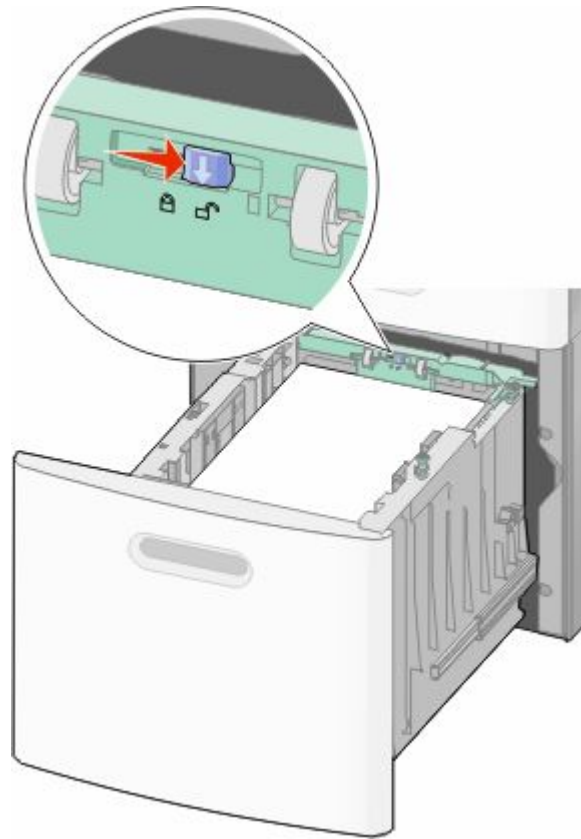

**4** Push the length guide release latch to raise the length guide, slide the guide to the correct position for the paper size being loaded, and then lock the guide.

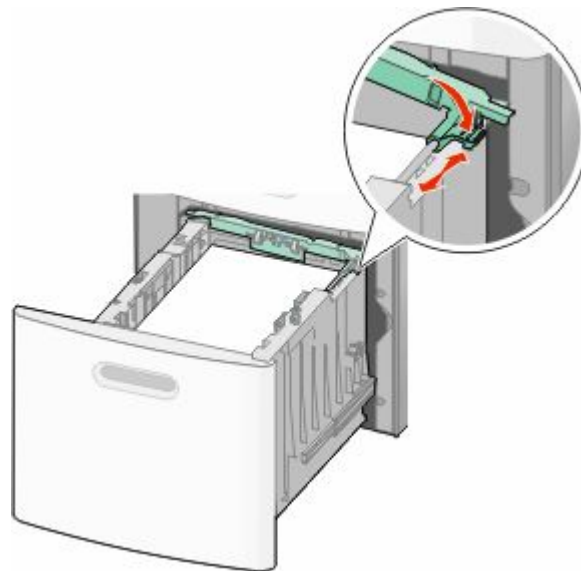

5 Flex the sheets back and forth to loosen them, and then fan them. Do not fold or crease the paper. Straighten the edges on a level surface.



6 Load the paper stack:

- Print side facedown for single-sided printing
- Print side faceup for duplex printing

**Note:** Paper must be loaded differently in the trays if an optional StapleSmart II Finisher is installed.

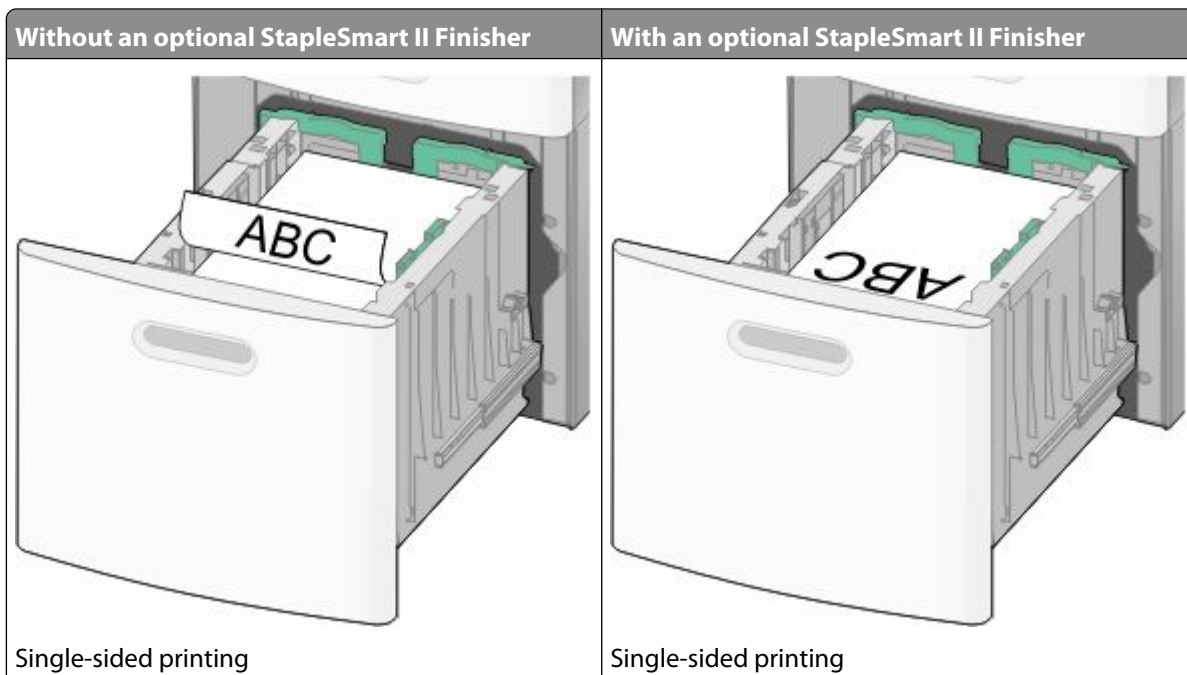

Without an optional StapleSmart II Finisher

With an optional StapleSmart II Finisher

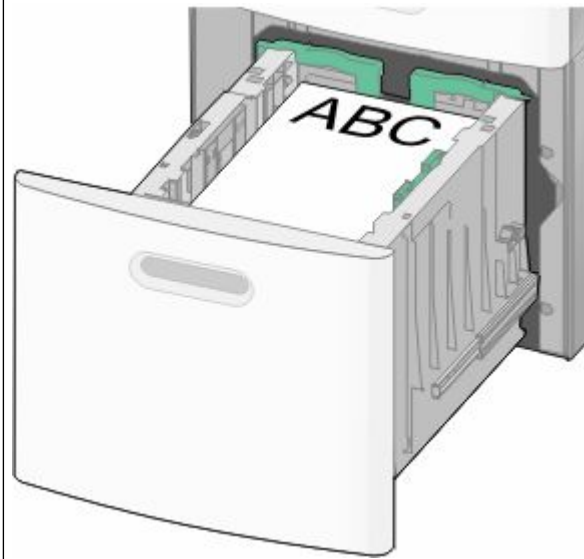

Duplex (two-sided) printing

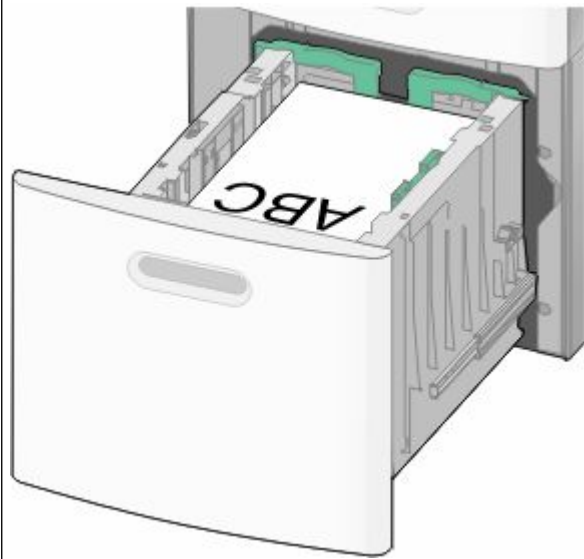

Duplex (two-sided) printing

**Note:** Notice the maximum fill line on the side of the tray which indicates the maximum height for loading paper. Do not overload the tray.

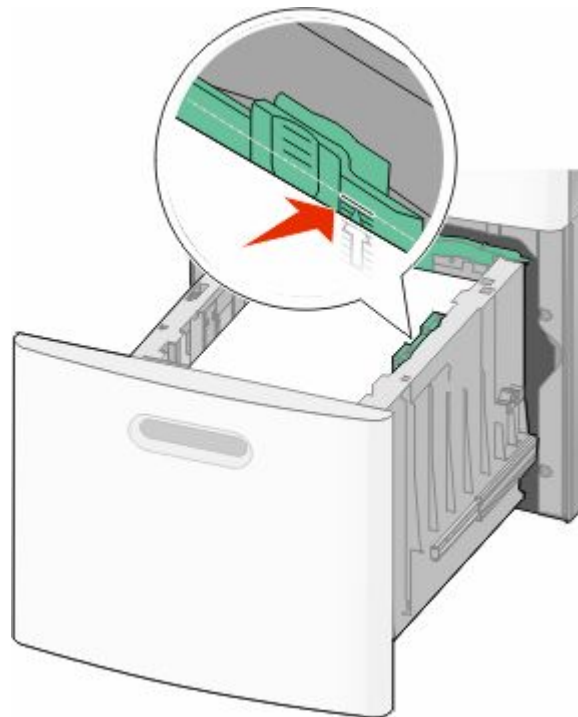

7 Insert the tray.

# Loading the multipurpose feeder

1 Pull down the multipurpose feeder door.



2 Pull out the extension until it is fully extended.



3 Slide the width guide to the far right.

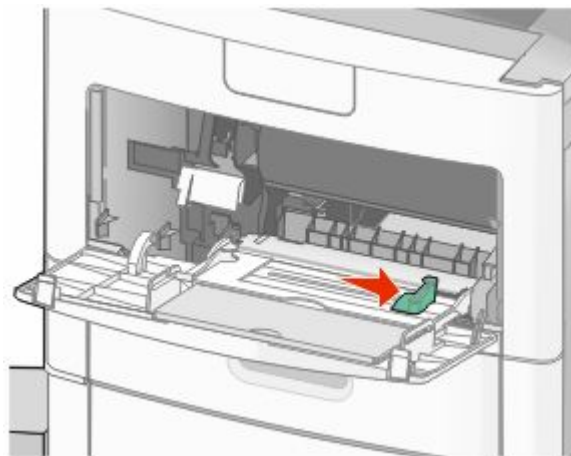

4 Flex the sheets of paper or specialty media back and forth to loosen them, and then fan them. Do not fold or crease them. Straighten the edges on a level surface.

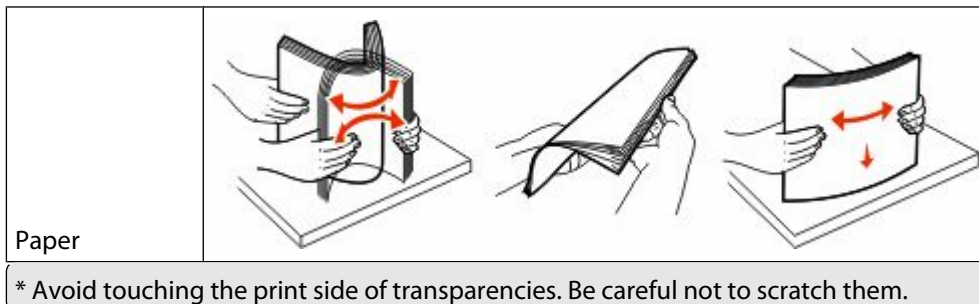

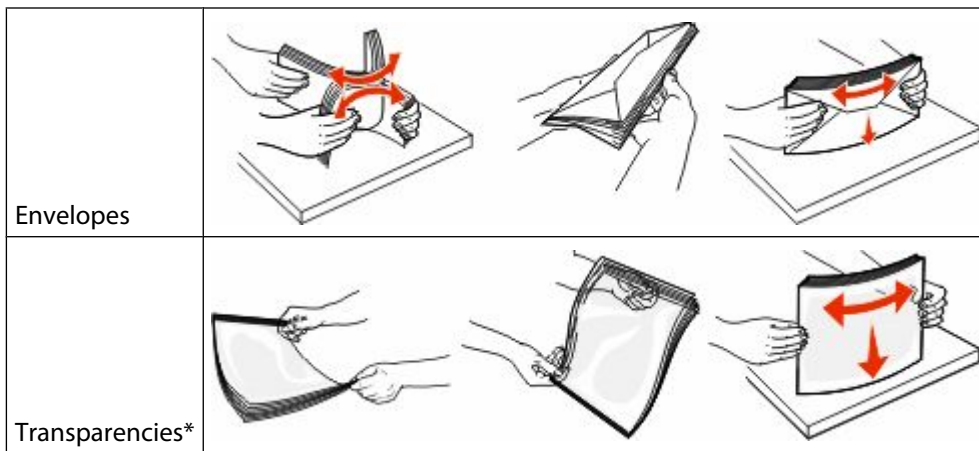

\* Avoid touching the print side of transparencies. Be careful not to scratch them.

**5** Load the paper or specialty media. Slide the stack gently into the multipurpose feeder until it comes to a stop.

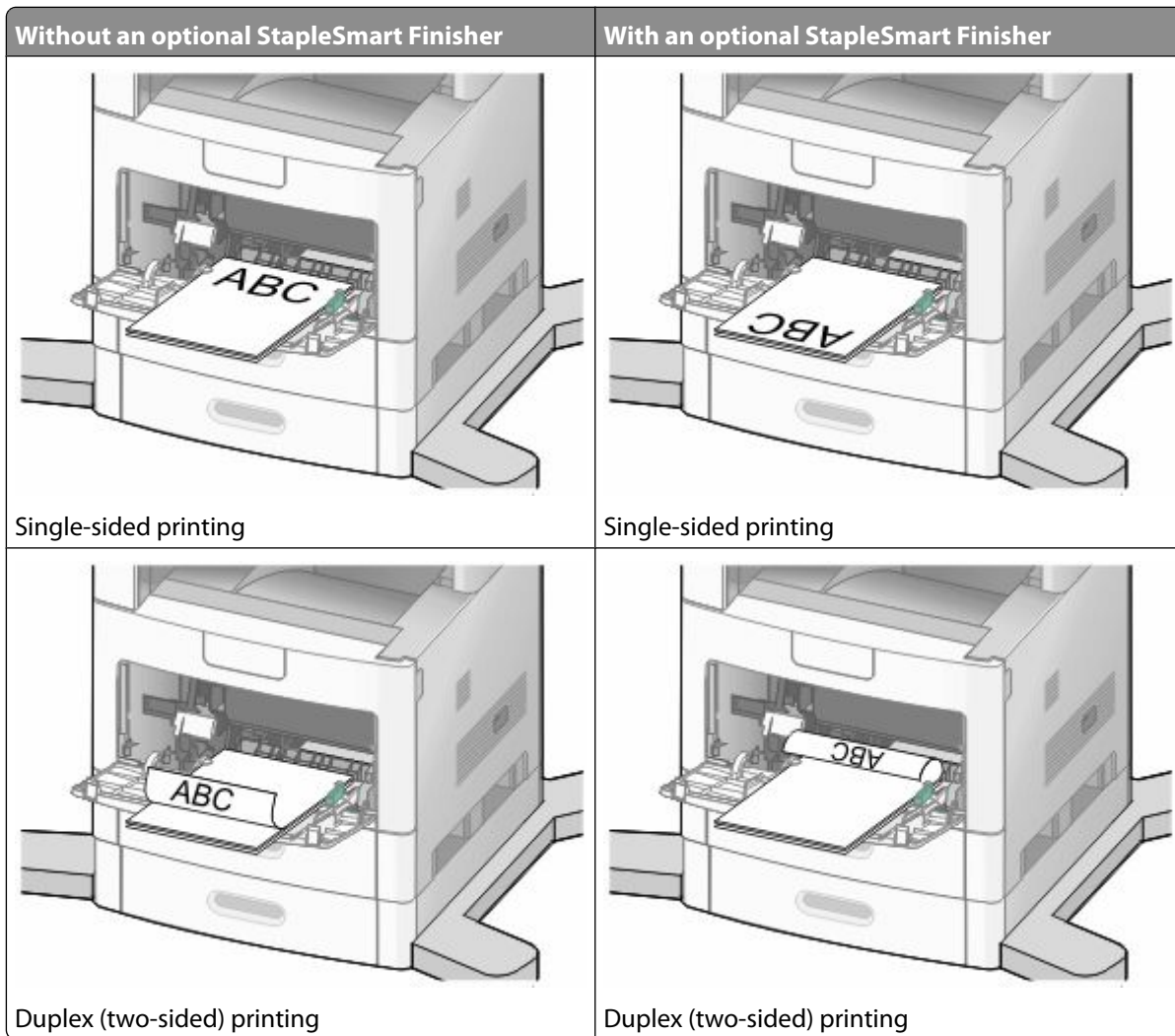

**Notes:**

- Do not exceed the maximum stack height by forcing paper under the stack height limiter.
- Do not load or close a tray while a job is printing.
- Load only one size and type of media at a time.
- Load envelopes with the flap side up.

**Warning—Potential Damage:** Never use envelopes with stamps, clasps, snaps, windows, coated linings, or self-stick adhesives. These envelopes may severely damage the printer.

- 6 Adjust the width guide to lightly touch the edge of the paper stack. Make sure the paper fits loosely in the multipurpose feeder, lies flat, and is not bent or wrinkled.
- 7 From the printer control panel, set the Paper Size and Paper Type.

## Loading the envelope feeder

- 1 Adjust the envelope support for the length of envelope you are loading:
  - **Short envelopes**—Fully close the envelope support.
  - **Medium-length envelopes**—Extend the envelope support to the middle position.
  - **Long envelopes**—Fully open the envelope support.
- 2 Lift the envelope weight back toward the printer.

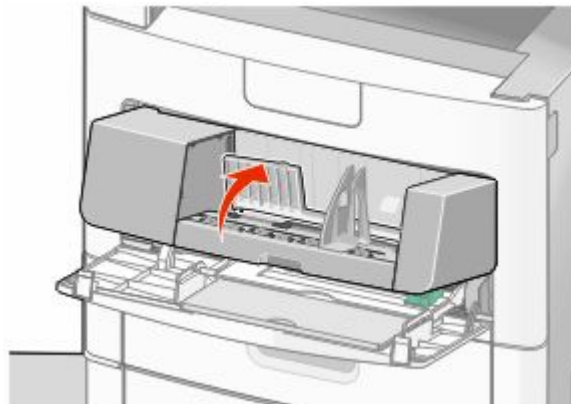

- 3 Slide the width guide to the right.

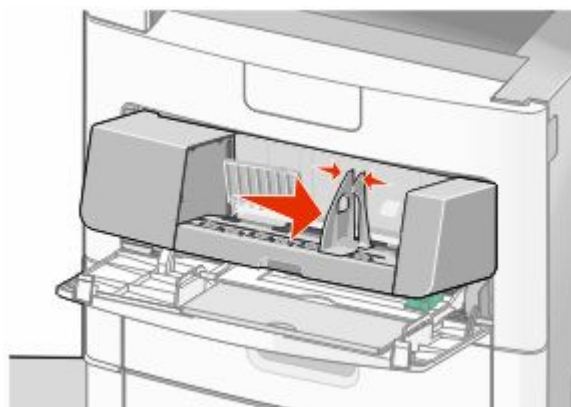



**4** Prepare the envelopes for loading.

Flex the envelopes back and forth to loosen them, and then fan them. Do not fold or crease the paper. Straighten the edges on a level surface.



**5** Load the stack of envelopes flap side down.

**Warning—Potential Damage:** Never use envelopes with stamps, clasps, snaps, windows, coated linings, or self-stick adhesives. These envelopes may severely damage the printer.

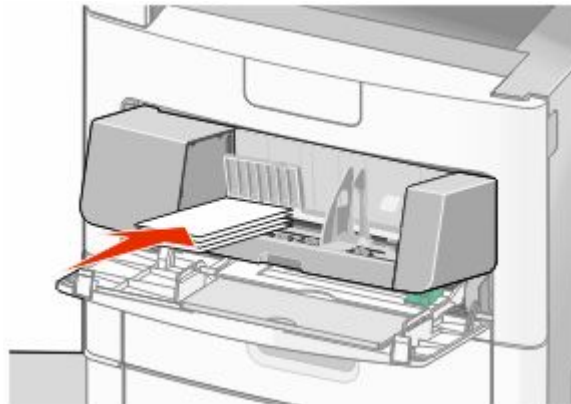

**Note:** Do not exceed the maximum stack height by forcing paper under the stack height limiter.

- 6** Adjust the width guide to lightly touch the edge of the paper stack.
- 7** Lower the envelope weight to touch the paper stack.
- 8** From the printer control panel, set the Paper Size and Paper Type.

## Linking and unlinking trays

### Linking trays

Tray linking is useful for large print jobs or multiple copies. When one linked tray is empty, paper feeds from the next linked tray. When the Paper Size and Paper Type settings are the same for any trays, the trays are automatically linked.

The printer automatically senses the Paper Size setting according to the position of the paper guides in each tray except the multipurpose feeder. The printer can sense A4, A5, JIS B5, Letter, Legal, Executive, and Universal paper sizes. The multipurpose feeder and trays using other paper sizes can be linked manually using the Paper Size menu available from the Paper Size/Type menu.

**Note:** To link the multipurpose feeder, Configure MP must be set to Cassette in the Paper menu in order for MP Feeder Size to appear as a menu item.

The Paper Type setting must be set for all trays from the Paper Type menu available from the Paper Size/Type menu.

## Unlinking trays

Unlinked trays have settings that are *not* the same as the settings of any other tray.

To unlink a tray, change the following tray settings so that they do not match the settings of any other tray:

- Paper Type (for example: Plain Paper, Letterhead, Custom Type <x>)  
Paper Type names describe the paper characteristics. If the name that best describes your paper is used by linked trays, assign a different Paper Type name to the tray, such as Custom Type <x>, or define your own custom name.
- Paper Size (for example: letter, A4, statement)  
Load a different paper size to change the Paper Size setting for a tray automatically. Paper Size settings for the multipurpose feeder are not automatic; they must be set manually from the Paper Size menu.

**Warning—Potential Damage:** Do not assign a Paper Type name that does not accurately describe the type of paper loaded in the tray. The temperature of the fuser varies according to the specified Paper Type. Paper may not be properly processed if an inaccurate Paper Type is selected.

## Assigning a custom paper type name

Assign a custom paper type name to a tray when linking or unlinking the tray.

- 1 Make sure the printer is on and **Ready** appears.
- 2 From the home screen, touch .
- 3 Touch **Paper Menu**.
- 4 Touch **Paper Size/Type**.
- 5 Touch the paper type arrows for the desired tray until the correct custom type appears.
- 6 Touch the tray number or **MP Feeder Type**.
- 7 Touch **Submit**.

## Changing a Custom Type <x> name

You can use the Embedded Web Server or MarkVision™ to define a name other than Custom Type <x> for each of the custom paper types that are loaded. When a Custom Type <x> name is changed, the menus display the new name instead of Custom Type <x>.

To change a Custom Type <x> name from the Embedded Web Server:

- 1 Type the printer IP address into the address field of your Web browser.  
**Note:** If you do not know the IP address of the printer, then print a network setup page and locate the IP address in the TCP/IP section.
- 2 Click **Settings**.
- 3 Under Default Settings, click **Paper Menu**.
- 4 Click **Custom Names**.
- 5 Type a name for the paper type in a Custom Name <x> box.  
**Note:** This custom name will replace a custom type <x> name under the Custom Types and Paper Size/Type menus.

**6** Click **Submit**.

**7** Click **Custom Types**.

**Custom Types** appears, followed by your custom name.

**8** Select a Paper Type setting from the list next to your custom name.

**9** Click **Submit**.

# Paper and specialty media guidelines

## Paper guidelines

Selecting the correct paper or specialty media reduces printing problems. For the best print quality, try a sample of the paper or specialty media before buying large quantities.

## Paper characteristics

The following paper characteristics affect print quality and reliability. Consider these characteristics when evaluating new paper stock.

### Weight

The printer can automatically feed paper weights from 60–176 g/m<sup>2</sup> (16–47 lb bond) grain long. Paper lighter than 60 g/m<sup>2</sup> (16 lb) might not be stiff enough to feed properly, causing jams. For best performance, use 75 g/m<sup>2</sup> (20 lb bond) grain long paper. For paper smaller than 182 x 257 mm (7.2 x 10.1 in.), we recommend 90 g/m<sup>2</sup> (24 lb) or heavier paper.

### Curl

Curl is the tendency for paper to curl at its edges. Excessive curl can cause paper feeding problems. Curl can occur after the paper passes through the printer, where it is exposed to high temperatures. Storing paper unwrapped in hot, humid, cold, or dry conditions, even in the trays, can contribute to paper curling prior to printing and can cause feeding problems.

### Smoothness

Paper smoothness directly affects print quality. If paper is too rough, then toner cannot fuse to it properly. If paper is too smooth, then it can cause paper feeding or print quality issues. Always use paper between 100 and 300 Sheffield points; smoothness between 150 and 250 Sheffield points produces the best print quality.

### Moisture content

The amount of moisture in paper affects both print quality and the ability of the printer to feed the paper correctly. Leave paper in its original wrapper until it is time to use it. This limits the exposure of paper to moisture changes that can degrade its performance.

Condition paper before printing by storing it in its original wrapper in the same environment as the printer for 24 to 48 hours before printing. Extend the time several days if the storage or transportation environment is very different from the printer environment. Thick paper may also require a longer conditioning period.

### Grain direction

Grain refers to the alignment of the paper fibers in a sheet of paper. Grain is either *grain long*, running the length of the paper, or *grain short*, running the width of the paper.

For 60–176 g/m<sup>2</sup> (16–47 lb bond) paper, grain long paper is recommended. For paper heavier than 176 g/m<sup>2</sup>, grain short is recommended.

## Fiber content

Most high-quality xerographic paper is made from 100% chemically treated pulped wood. This content provides the paper with a high degree of stability resulting in fewer paper feeding problems and better print quality. Paper containing fibers such as cotton can negatively affect paper handling.

For detailed information on paper with recycled fiber content, see “Using recycled paper and other office papers” on page 86.

## Unacceptable paper

The following paper types are not recommended for use with the printer:

- Chemically treated papers used to make copies without carbon paper, also known as carbonless papers, carbonless copy paper (CCP), or no carbon required (NCR) paper
- Preprinted papers with chemicals that may contaminate the printer
- Preprinted papers that can be affected by the temperature in the printer fuser
- Preprinted papers that require a registration (the precise print location on the page) greater than  $\pm 2.3$  mm ( $\pm 0.9$  in.), such as optical character recognition (OCR) forms

In some cases, registration can be adjusted with a software application to successfully print on these forms.

- Coated papers (erasable bond), synthetic papers, thermal papers
- Rough-edged, rough or heavily textured surface papers, or curled papers
- Recycled papers that fail EN12281:2002 (European)
- Paper weighing less than 60 g/m<sup>2</sup> (16 lb)
- Multiple-part forms or documents

## Selecting paper

Using appropriate paper prevents jams and helps ensure trouble-free printing.

To help avoid jams and poor print quality:

- *Always* use new, undamaged paper.
- Before loading paper, know the recommended print side of the paper. This information is usually indicated on the paper package.
- *Do not* use paper that has been cut or trimmed by hand.
- *Do not* mix paper sizes, types, or weights in the same source; mixing results in jams.
- *Do not* use coated papers unless they are specifically designed for electrophotographic printing.

## Selecting preprinted forms and letterhead

Use these guidelines when selecting preprinted forms and letterhead:

- Use grain long for 60 to 90 g/m<sup>2</sup> weight paper.
- Use only forms and letterhead printed using an offset lithographic or engraved printing process.
- Avoid papers with rough or heavily textured surfaces.

Use papers printed with heat-resistant inks designed for use in xerographic copiers. The ink must be able to withstand temperatures up to 230°C (446°F) without melting or releasing hazardous emissions. Use inks that are not affected by the resin in toner. Inks that are oxidation-set or oil-based generally meet these requirements; latex inks might not. When in doubt, contact the paper supplier.

Preprinted papers such as letterhead must be able to withstand temperatures up to 230°C (446°F) without melting or releasing hazardous emissions.

## Using recycled paper and other office papers

Recycled office paper produced specifically for use in laser (electrophotographic) printers may be used in your printer. However, no blanket statement can be made that *all* recycled paper will feed well.

Generally, the following property guidelines apply to recycled paper.

- Low moisture content (4–5%)
- Suitable smoothness (100–200 Sheffield units, or 140–350 Bendtsen units, European)

**Note:** Some much smoother papers (such as premium 24 lb laser papers, 50–90 Sheffield units) and much rougher papers (such as premium cotton papers, 200–300 Sheffield units) have been engineered to work very well in laser printers, despite surface texture. Before using these types of paper, consult your paper supplier.

- Suitable sheet-to-sheet coefficient of friction (0.4–0.6)
- Sufficient bending resistance in the direction of feed

Recycled paper, paper of lower weight (<60 g/m<sup>2</sup> [16 lb bond]) and/or lower caliper (<3.8 mils [0.1 mm]), and paper that is cut grain-short for portrait (or short-edge) fed printers may have lower bending resistance than is required for reliable paper feeding. Before using these types of paper for laser (electrophotographic) printing, consult your paper supplier. Remember that these are general guidelines only and that paper meeting these guidelines may still cause paper feeding problems in any laser printer (for example, if the paper curls excessively under normal printing conditions).

## Storing paper

Use these paper storage guidelines to help avoid jams and uneven print quality:

- For best results, store paper where the temperature is 21°C (70°F) and the relative humidity is 40%. Most label manufacturers recommend printing in a temperature range of 18 to 24°C (65 to 75°F) with relative humidity between 40 and 60%.
- Store paper in cartons when possible, on a pallet or shelf, rather than on the floor.
- Store individual packages on a flat surface.
- Do not store anything on top of individual paper packages.

# Supported paper sizes, types, and weights

The following tables provide information on standard and optional paper sources and the types of paper they support.

**Note:** For an unlisted paper size, configure a Universal Paper Size.

## Paper sizes supported by the printer

Paper size	Dimensions	250- or 550-sheet trays (standard or optional)	Optional 2000-sheet tray	Multipurpose feeder	Duplex unit
<b>A4</b>	210 x 297 mm (8.3 x 11.7 in.)	✓	✓	✓	✓
<b>A5</b>	148 x 210 mm (5.8 x 8.3 in.)	✓	X	✓	✓
<b>A6<sup>1,2</sup></b>	105 x 148 mm (4.1 x 5.8 in.)	X	X	✓	X
<b>JIS B5</b>	182 x 257 mm (7.2 x 10.1 in.)	✓	X	✓	✓
<b>Letter</b>	216 x 279 mm (8.5 x 11 in.)	✓	✓	✓	✓
<b>Legal</b>	216 x 356 mm (8.5 x 14 in.)	✓	✓	✓	✓
<b>Executive</b>	184 x 267 mm (7.3 x 10.5 in.)	✓	X	✓	✓
<b>Oficio<sup>1</sup></b>	216 x 340 mm (8.5 x 13.4 in.)	✓	X	✓	✓
<b>Folio<sup>1</sup></b>	216 x 330 mm (8.5 x 13 in.)	✓	X	✓	✓
<b>Statement<sup>1</sup></b>	140 x 216 mm (5.5 x 8.5 in.)	✓	X	✓	X

<sup>1</sup> This size appears in the Paper Size menu only when the paper source does not support size sensing or when size sensing is turned off.

<sup>2</sup> Only the standard exit bin supports this size.

<sup>3</sup> This size setting formats the page for 216 x 356 mm (8.5 x 14 in.) unless the size is specified by the software application.

<sup>4</sup> To support duplexing, the Universal width must be between 148 mm (5.8 in) and 216 mm (8.5 in); Universal length must be between 182 mm (7.2 in) and 356 mm (14 in).

Paper size	Dimensions	250- or 550-sheet trays (standard or optional)	Optional 2000-sheet tray	Multipurpose feeder	Duplex unit
<b>Universal</b> <sup>3,4</sup>	138 x 210 mm (5.5 x 8.3 in.) up to 216 x 356 mm (8.5 x 14 in.)	✓	X	✓	X
	70 x 127 mm (2.8 x 5 in.) up to 216 x 356 mm (8.5 x 14 in.)	X	X	✓	X
	148 x 182 mm (5.8 x 7.7 in.) up to 216 x 356 mm (8.5 x 14 in.)	✓	X	✓	✓
<b>7 3/4 Envelope (Monarch)</b>	98 x 191 mm (3.9 x 7.5 in.)	X	X	✓	X
<b>9 Envelope</b>	98 x 225 mm (3.9 x 8.9 in.)	X	X	✓	X
<b>10 Envelope</b>	105 x 241 mm (4.1 x 9.5 in.)	X	X	✓	X
<b>DL Envelope</b>	110 x 220 mm (4.3 x 8.7 in.)	X	X	✓	X
<b>Other Envelope</b>	98 x 162 mm (3.9 x 6.4 in.) to 176 x 250 mm (6.9 x 9.8 in.)	X	X	✓	X

<sup>1</sup> This size appears in the Paper Size menu only when the paper source does not support size sensing or when size sensing is turned off.

<sup>2</sup> Only the standard exit bin supports this size.

<sup>3</sup> This size setting formats the page for 216 x 356 mm (8.5 x 14 in.) unless the size is specified by the software application.

<sup>4</sup> To support duplexing, the Universal width must be between 148 mm (5.8 in) and 216 mm (8.5 in); Universal length must be between 182 mm (7.2 in) and 356 mm (14 in).

**Note:** An optional 250-sheet Universally Adjustable Tray is available for sizes smaller than A5, such as index cards.



## Paper types and weights supported by the printer

The printer engine supports 60–176 g/m<sup>2</sup> (16–47 lb) paper weights. The duplex unit supports 63–170 g/m<sup>2</sup> (17–45 lb) paper weights.

Paper type	250- or 550-sheet trays (standard or optional)	Optional 2000-sheet tray	Multipurpose feeder	Duplex unit
<b>Paper</b> <ul style="list-style-type: none"> <li>• Plain</li> <li>• Bond</li> <li>• Colored</li> <li>• Custom</li> <li>• Letterhead</li> <li>• Light</li> <li>• Heavy</li> <li>• Preprinted</li> <li>• Rough/Cotton</li> <li>• Recycled</li> </ul>	✓	✓	✓	✓
<b>Card stock</b>	✓	✓	✓	✓
<b>Envelopes</b>	X	X	✓	X
<b>Labels</b> <sup>1</sup>	✓	✓	✓	✓
<b>Transparencies</b>	✓	✓	✓	✓

<sup>1</sup> Single-sided paper labels designed for laser printers are supported for occasional use: no more than 20 pages of labels a month. Vinyl, pharmacy, and dual-web labels are not supported.

**Warning—Potential Damage:** Printing more than 20 pages of paper labels a month may damage the duplex unit.

## Paper types and weights supported by the output bins

Use this table to determine the possible output destinations of print jobs which use supported paper types and weights. The paper capacity of each output bin is listed in parentheses. Paper capacity estimations are calculated based on 75 g/m<sup>2</sup> (20 lb) paper.

The finisher supports 60–176 g/m<sup>2</sup> (16–47 lb) paper weights.

Paper type	Standard exit bin (350 or 550 sheets)	Optional hardware		
		Output Expander (550 sheets) or High Capacity Output Stacker (1850 sheets)	4-Bin Mailbox (400 sheets) <sup>1</sup>	StapleSmart II Finisher (500 sheets) <sup>2</sup>
<b>Paper</b> <ul style="list-style-type: none"> <li>• Plain</li> <li>• Bond</li> <li>• Colored</li> <li>• Custom</li> <li>• Letterhead</li> <li>• Light</li> <li>• Heavy</li> <li>• Preprinted</li> <li>• Rough/Cotton</li> <li>• Recycled</li> </ul>	✓	✓	✓	✓
<b>Card stock</b>	✓	✓	X	X
<b>Envelopes</b>	✓	✓	X	X
<b>Labels</b>	✓	✓	X	X
<b>Transparencies</b>	✓	✓	X	X
<sup>1</sup> Supports 60-90 g/m <sup>2</sup> (16-24 lb) paper weights. <sup>2</sup> Maximum of 50 sheets of 75 g/m <sup>2</sup> (20 lb) paper per stapled packet. Results may vary with heavier paper.				

# Copying

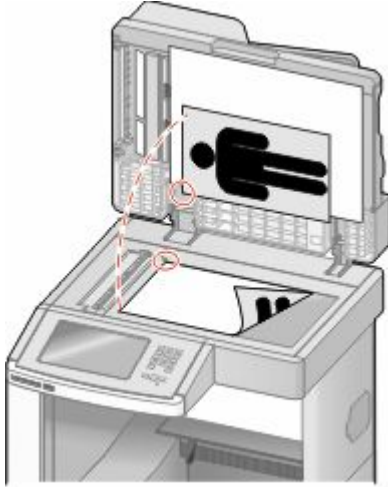
ADF	Scanner glass
 <p data-bbox="149 835 623 863">Use the ADF for multiple-page documents.</p>	 <p data-bbox="641 835 1440 926">Use the scanner glass for single pages, small items (such as postcards or photos), transparencies, photo paper, or thin media (such as magazine clippings).</p>

## Making copies

### Making a quick copy

- 1 Load an original document faceup, short edge first into the ADF or facedown on the scanner glass.  
**Note:** Do not load postcards, photos, small items, transparencies, photo paper, or thin media (such as magazine clippings) into the ADF. Place these items on the scanner glass.
- 2 If you are loading a document into the ADF, then adjust the paper guides.
- 3 From the printer control panel, press .
- 4 If you placed the document on the scanner glass, then touch **Finish the Job** to return to the home screen.

### Copying using the ADF

- 1 Load an original document faceup, short edge first into the ADF.  
**Note:** Do not load postcards, photos, small items, transparencies, photo paper, or thin media (such as magazine clippings) into the ADF. Place these items on the scanner glass.
- 2 Adjust the paper guides.
- 3 On the home screen, touch **Copy**, or use the keypad to enter the number of copies.  
The copy screen appears.

- 4 Change the copy settings as needed.
- 5 Touch **Copy It**.

## Copying using the scanner glass

- 1 Place an original document facedown on the scanner glass in the upper left corner.
- 2 On the home screen, touch **Copy**, or use the keypad to enter the number of copies.  
The copy screen appears.
- 3 Change the copy settings as needed.
- 4 Touch **Copy It**.
- 5 If you have more pages to scan, then place the next document on the scanner glass, and then touch **Scan the Next Page**.
- 6 Touch **Finish the Job** to return to the home screen.

## Copying photos

- 1 Place a photo facedown on the scanner glass in the upper left corner.
- 2 On the home screen, touch **Copy**.
- 3 Touch **Options**.
- 4 Touch **Content**.
- 5 Touch **Photograph**.
- 6 Touch **Done**.
- 7 Touch **Copy It**.
- 8 Touch **Scan the Next Page** or **Finish the Job**.

## Copying on specialty media

### Making transparencies

- 1 Load an original document faceup, short edge first into the ADF or facedown on the scanner glass.  
**Note:** Do not load postcards, photos, small items, transparencies, photo paper, or thin media (such as magazine clippings) into the ADF. Place these items on the scanner glass.
- 2 If you are loading a document into the ADF, then adjust the paper guides.
- 3 On the home screen, touch **Copy**.
- 4 Touch **Copy from**, and then identify the size of the original document.
- 5 Touch **Copy to**, and then touch the tray that contains transparencies, or touch **Manual Feeder** and then place transparencies in the multipurpose feeder.

- 6 Touch the desired size of the transparencies, and then touch **Continue**.
- 7 Touch the arrows until **Transparency** appears.
- 8 Touch **Transparency**, and then touch **Continue**.
- 9 Touch **Copy It**.

## Copying to letterhead

- 1 Load an original document faceup, short edge first into the ADF or facedown on the scanner glass.  
**Note:** Do not load postcards, photos, small items, transparencies, photo paper, or thin media (such as magazine clippings) into the ADF. Place these items on the scanner glass.
- 2 If you are loading a document into the ADF, then adjust the paper guides.
- 3 On the home screen, touch **Copy**.
- 4 Touch **Copy from**, and then identify the size of the original document.
- 5 Touch **Copy to**, and then touch **Manual Feeder** and place letterhead face up, top edge first in the multipurpose feeder.
- 6 Touch the desired size of the letterhead, and then touch **Continue**.
- 7 Touch the arrows until **Letterhead** appears.
- 8 Touch **Letterhead**, and then touch **Continue**.
- 9 Touch **Copy It**.

## Customizing copy settings

### Copying from one size to another

- 1 Load an original document faceup, short edge first into the ADF or facedown on the scanner glass.  
**Note:** Do not load postcards, photos, small items, transparencies, photo paper, or thin media (such as magazine clippings) into the ADF. Place these items on the scanner glass.
- 2 If you are loading a document into the ADF, then adjust the paper guides.
- 3 On the home screen, touch **Copy**.
- 4 Touch **Copy from**, and then identify the size of the original document.
- 5 Touch **Copy to**, and then select the size you want the copy to be.  
**Note:** If you select a paper size that is different from the “Copy from” size, then the printer will scale the size automatically.
- 6 Touch **Copy It**.

## Making copies using paper from a selected tray

During the copy process, you can select the tray that contains the paper type of choice. For example, if specialty media is located in the multipurpose feeder, and you want to make copies on that media:

- 1 Load an original document faceup, short edge first into the ADF or facedown on the scanner glass.  
**Note:** Do not load postcards, photos, small items, transparencies, photo paper, or thin media (such as magazine clippings) into the ADF. Place these items on the scanner glass.
- 2 If you are loading a document into the ADF, then adjust the paper guides.
- 3 On the home screen, touch **Copy**.
- 4 Touch **Copy from**, and then identify the size of the original document.
- 5 Touch **Copy to**, and then touch **Manual Feeder** or the tray that contains the paper type you want.  
**Note:** If you choose Manual Feeder, then you will need to also select the paper size and type.
- 6 Touch **Copy It**.

## Copying a document that contains mixed paper sizes

Use the ADF to copy an original document that contains mixed paper sizes. Depending on the paper sizes loaded and the "Copy to" and "Copy from" settings, each copy is either printed on mixed paper sizes (Example 1) or scaled to fit a single paper size (Example 2).

### Example 1: Copying to mixed paper sizes

The printer has two paper trays, one tray loaded with letter-size paper and the other with legal-size paper. A document that contains letter- and legal-size pages needs to be copied.

- 1 Load an original document faceup, short edge first into the ADF or facedown on the scanner glass.  
**Note:** Do not load postcards, photos, small items, transparencies, photo paper, or thin media (such as magazine clippings) into the ADF. Place these items on the scanner glass.
- 2 If you are loading a document into the ADF, then adjust the paper guides.
- 3 On the home screen, touch **Copy**.
- 4 Touch **Copy from**, and then touch **Auto Size Sense**.
- 5 Touch **Copy to**, and then touch **Auto Size Match**.
- 6 Touch **Copy It**.  
The scanner identifies the mixed paper sizes as they scan. Copies are printed on mixed paper sizes corresponding to the paper sizes of the original document.

## Example 2: Copying to a single paper size

The printer has one paper tray, loaded with letter-size paper. A document that contains letter- and legal-size pages needs to be copied.

- 1 Load an original document faceup, short edge first into the ADF or facedown on the scanner glass.

**Note:** Do not load postcards, photos, small items, transparencies, photo paper, or thin media (such as magazine clippings) into the ADF. Place these items on the scanner glass.

- 2 If you are loading a document into the ADF, then adjust the paper guides.

- 3 On the home screen, touch **Copy**.

- 4 Touch **Copy from**, and then touch **Mixed Letter/Legal**.

- 5 Touch **Copy to**, and then touch **Letter**.

- 6 Touch **Copy It**.

The scanner identifies the mixed paper sizes as they scan and then scales the legal-size pages to print on letter-size paper.

## Copying on both sides of the paper (duplexing)

- 1 Load an original document faceup, short edge first into the ADF or facedown on the scanner glass.

**Note:** Do not load postcards, photos, small items, transparencies, photo paper, or thin media (such as magazine clippings) into the ADF. Place these items on the scanner glass.

- 2 If you are loading a document into the ADF, adjust the paper guides.

- 3 On the home screen, touch **Copy**.

- 4 From the Sides (Duplex) area, touch the button that looks the way you want your copies duplexed.

The first number represents sides of the original documents; the second number represents sides of the copy. For example, select 1-sided to 2-sided if you have 1-sided original documents and you want 2-sided copies.

- 5 Touch **Copy It**.

## Reducing or enlarging copies

Copies can be reduced to 25% of the original document size or enlarged to 400% of the original document size. The factory default setting for Scale is Auto. If you leave Scale set to Auto, the content of your original document will be scaled to fit the size of the paper onto which you are copying.

To reduce or enlarge a copy:

- 1 Load an original document faceup, short edge first into the ADF or facedown on the scanner glass.

**Note:** Do not load postcards, photos, small items, transparencies, photo paper, or thin media (such as magazine clippings) into the ADF. Place these items on the scanner glass.

- 2 If you are loading a document into the ADF, then adjust the paper guides.

- 3 On the home screen, touch **Copy**.

- 4 From the Scale area, touch the arrows to enlarge or reduce your copies.  
Touching “Copy to” or “Copy from” after setting Scale manually changes the scale value back to Auto.
- 5 Touch **Copy It**.

## Adjusting copy quality

- 1 Load an original document faceup, short edge first into the ADF or facedown on the scanner glass.  
**Note:** Do not load postcards, photos, small items, transparencies, photo paper, or thin media (such as magazine clippings) into the ADF. Place these items on the scanner glass.
- 2 If you are loading a document into the ADF, then adjust the paper guides.
- 3 On the home screen, touch **Copy**.
- 4 Touch **Options**.
- 5 Touch **Content**.
- 6 Touch the button that best represents what you are copying:
  - **Text**—Used for original documents that are mostly text or line art
  - **Text/Photo**—Used when the original documents are a mixture of text and graphics or pictures
  - **Photograph**—Used when the original document is a high-quality photograph or inkjet print
  - **Printed Image**—Used when copying halftone photographs, graphics such as documents printed on a laser printer, or pages from a magazine or newspaper that are composed primarily of images
- 7 Touch **Done**.
- 8 Touch **Copy It**.

## Collating copies

If you print multiple copies of a document, then you can choose to print each copy as a set (collated) or to print the copies as groups of pages (not collated).

### Collated



### Not collated



By default, Collate is set to On. If you do not want to collate your copies, then change the setting to Off.

To turn collation off:

- 1 Load an original document faceup, short edge first into the ADF or facedown on the scanner glass.  
**Note:** Do not load postcards, photos, small items, transparencies, photo paper, or thin media (such as magazine clippings) into the ADF. Place these items on the scanner glass.
- 2 If you are loading a document into the ADF, then adjust the paper guides.
- 3 On the home screen, touch **Copy**.
- 4 Use the keypad to enter the number of copies.



5 Touch **Off** if you do not want your copies collated.

6 Touch **Copy It**.

## Placing separator sheets between copies

1 Load an original document faceup, short edge first into the ADF or facedown on the scanner glass.

**Note:** Do not load postcards, photos, small items, transparencies, photo paper, or thin media (such as magazine clippings) into the ADF. Place these items on the scanner glass.

2 If you are loading a document into the ADF, then adjust the paper guides.

3 On the home screen, touch **Copy**.

4 Touch **Options**.

5 Touch **Separator Sheets**.

**Note:** Collate must be On for the separator sheets to be placed between copies. If Collate is Off, the separator sheets are added to the end of the print job.

6 Select one of the following:

- **Between Copies**
- **Between Jobs**
- **Between Pages**

7 Touch **Done**.

8 Touch **Copy It**.

## Copying multiple pages onto a single sheet

In order to save paper, you can copy either two or four consecutive pages of a multiple-page document onto a single sheet of paper.

### Notes:

- The Paper Size must be set to Letter, Legal, A4, or B5 JIS.
- The Copy Size must be set to 100%.

1 Load an original document faceup, short edge first into the ADF or facedown on the scanner glass.

**Note:** Do not load postcards, photos, small items, transparencies, photo paper, or thin media (such as magazine clippings) into the ADF. Place these items on the scanner glass.

2 If you are loading a document into the ADF, then adjust the paper guides.

3 On the home screen, touch **Copy**.

4 Select a duplex setting.

5 Touch **Options**.

6 Touch **Paper Saver**.

7 Select the desired output.

- 8 Touch **Print Page Borders** if you want a box drawn around each page of the copies.
- 9 Touch **Done**.
- 10 Touch **Copy It**.

## Creating a custom job (job build)

The custom job or job build is used to combine one or more sets of original documents into a single copy job. Each set may be scanned using different job parameters. When a copy job is submitted and Custom Job is enabled, the scanner scans the first set of original documents using the supplied parameters, and then it scans the next set with the same or different parameters.

The definition of a set depends on the scan source:

- If you scan a document on the scanner glass, a set consists of one page.
- If you scan multiple pages using the ADF, a set consists of all scanned pages until the ADF becomes empty.
- If you scan one page using the ADF, a set consists of one page.

For example:

- 1 Load an original document faceup, short edge first into the ADF or facedown on the scanner glass.  
**Note:** Do not load postcards, photos, small items, transparencies, photo paper, or thin media (such as magazine clippings) into the ADF. Place these items on the scanner glass.
- 2 If you are loading a document into the ADF, then adjust the paper guides.
- 3 On the home screen, touch **Copy**.
- 4 Touch **Options**.
- 5 Touch **Custom Job**.
- 6 Touch **On**.
- 7 Touch **Done**.
- 8 Touch **Copy It**.  
When the end of a set is reached, the scan screen appears.
- 9 Load the next document faceup, short edge first into the ADF or facedown on the scanner glass, and then touch **Scan the Automatic Document Feeder** or **Scan the flatbed**.  
**Note:** If required, change the job settings.
- 10 If you have another document to scan, load the next document faceup, short edge first into the ADF or facedown on the scanner glass, and then touch **Scan the Automatic Document Feeder** or **Scan the flatbed**. Otherwise, touch **Finish the job**.

# Job interrupt

Job interrupt pauses the current print job and lets you print copies.

**Note:** The Job Interrupt setting must be On for this feature to function.

- 1 Load an original document faceup, short edge first into the ADF or facedown on the scanner glass.  
**Note:** Do not load postcards, photos, small items, transparencies, photo paper, or thin media (such as magazine clippings) into the ADF. Place these items on the scanner glass.
- 2 If you are loading a document into the ADF, then adjust the paper guides.
- 3 From the printer control panel, press .
- 4 If you placed the document on the scanner glass, then touch **Finish the Job** to return to the home screen.

# Placing information on copies

## Placing the date and time at the top of each page

- 1 Load an original document faceup, short edge first into the ADF or facedown on the scanner glass.  
**Note:** Do not load postcards, photos, small items, transparencies, photo paper, or thin media (such as magazine clippings) into the ADF. Place these items on the scanner glass.
- 2 If you are loading a document into the ADF, then adjust the paper guides.
- 3 On the home screen, touch **Copy**.
- 4 Touch **Options**.
- 5 Touch **Header/Footer**.
- 6 Pick an area of the page to place the date and time.
- 7 Touch **Date/Time**, and then touch **Continue**.
- 8 Touch **Done**.
- 9 Touch **Copy It**.

## Placing an overlay message on each page

An overlay message can be placed on each page. The message choices are Urgent, Confidential, Copy, or Draft. To place a message on the copies:

- 1 Load an original document faceup, short edge first into the ADF or facedown on the scanner glass.  
**Note:** Do not load postcards, photos, small items, transparencies, photo paper, or thin media (such as magazine clippings) into the ADF. Place these items on the scanner glass.
- 2 If you are loading a document into the ADF, then adjust the paper guides.
- 3 On the home screen, touch **Copy**.
- 4 Touch **Options**.

- 5 Touch **Overlay**.
- 6 Touch the button containing the overlay you want to use.
- 7 Touch **Done**.
- 8 Touch **Copy It**.

## Canceling a copy job

### Canceling a copy job while the document is in the ADF

When the ADF begins processing a document, the scanning screen appears. To cancel the copy job, touch **Cancel Job** on the touch screen.

A “Canceling scan job” screen appears. The ADF clears all pages in the ADF and cancels the job.

### Canceling a copy job while copying pages using the scanner glass

Touch **Cancel Job** on the touch screen.

A “Canceling scan job” screen appears. Once the job is canceled, the copy screen appears.

### Canceling a copy job while the pages are being printed

- 1 Touch **Cancel Job** on the touch screen, or press  on the keypad.
- 2 Touch the job you want to cancel.
- 3 Touch **Delete Selected Jobs**.

The remaining print job is canceled. The home screen appears.

## Understanding the copy screens and options

### Copy from

This option opens a screen where you can enter the size of the documents you are going to copy.

- Touch a paper size button to select it as the “Copy from” setting. The copy screen appears with your new setting displayed.
- When “Copy from” is set to Mixed Letter/Legal, you can copy an original document that contains mixed paper sizes.
- When “Copy from” is set to Auto Size Sense, the scanner automatically determines the size of the original document.

## Copy to

This option opens a screen where you can enter the size and type of paper on which your copies will be printed.

- Touch a paper size button to select it as the “Copy to” setting. The copy screen appears with your new setting displayed.
- If the size settings for “Copy from” and “Copy to” are different, the printer automatically adjusts the Scale setting to accommodate the difference.
- If the type or size of paper that you want to copy onto is not loaded in one of the trays, touch **Manual Feeder**, and manually send the paper through the multipurpose feeder.
- When “Copy to” is set to Auto Size Match, each copy matches the size of the original document. If a matching paper size is not in one of the trays, the printer scales each copy to fit loaded paper.

## Scale

This option creates an image from your copy that is proportionally scaled anywhere between 25% and 400%. Scale can also be set for you automatically.

- When you want to copy from one size of paper to another, such as from legal-size to letter-size paper, setting the “Copy from” and “Copy to” paper sizes automatically changes the scale to keep all the original document information on your copy.
- Touch the left arrow to decrease the value by 1%; touch the right arrow to increase the value by 1%.
- Hold your finger on an arrow to make a continuous increment change.
- Hold your finger on an arrow for two seconds to cause the pace of the change to accelerate.

## Darkness

This option adjusts how light or dark your copies will turn out in relation to the original document.

## Content

This option tells the printer the original document type. Choose from Text, Text/Photo, Photograph, or Printed Image.

- **Text**—Emphasize sharp, black, high-resolution text against a clean, white background
- **Text/Photo**—Used when the original documents are a mixture of text and graphics or pictures
- **Photograph**—Tells the scanner to pay extra attention to graphics and pictures. This setting increases the time it takes to scan, but emphasizes a reproduction of the full dynamic range of tones in the original document.
- **Printed Image**—Used when copying halftone photographs, graphics such as documents printed on a laser printer, or pages from a magazine or newspaper that are composed primarily of images

## Sides (Duplex)

Use this option to select duplex settings. You can print copies on one or two sides, make two-sided copies (duplex) of two-sided original documents, make two-sided copies from one-sided original documents, or make one-sided copies (simplex) from two-sided original documents.

## Collate

This option keeps the pages of a print job stacked in sequence when printing multiple copies of the document. The factory default setting for Collate is on; the output pages of your copies will be ordered (1,2,3) (1,2,3) (1,2,3). If you want all the copies of each page to remain together, turn Collate off, and your copies will be ordered (1,1,1) (2,2,2) (3,3,3).

## Options

Touching the Options button opens a screen where you can change Paper Saver, Advanced Imaging, Custom Job, Separator Sheets, Margin Shift, Edge Erase, Header/Footer, Overlay, Content, Advanced Duplex, and Save as Shortcut settings.

### Paper Saver

This option lets you print two or more sheets of an original document together on the same page. Paper Saver is also called N-up printing. The N stands for Number. For example, 2-up would print two pages of your document on a single page, and 4-up would print four pages of your document on a single page. Touching Print Page Borders adds or removes the outline border surrounding the original document pages on the output page.

### Advanced Imaging

This option lets you adjust Background Removal, Contrast, Shadow Detail, Scan Edge to Edge, Color Balance, and mirror image before you copy the document.

### Custom Job

This option combines multiple scanning jobs into a single job.

### Separator Sheets

This option places a blank piece of paper between copies, pages, and print jobs. The separator sheets can be drawn from a tray that contains a type or color of paper that is different from the paper your copies are printed on.

### Margin Shift

This option increases the size of the margin a specified distance. This can be useful in providing space to bind or hole-punch copies. Use the increase or decrease arrows to set how much of a margin you want. If the additional margin is too large, then the copy will be cropped.

### Edge Erase

This option eliminates smudges or information around the edges of your document. You can choose to eliminate an equal area around all four sides of the paper, or pick a particular edge. Edge Erase erases whatever is within the selected area, leaving nothing printed on that portion of the paper.

### Header/Footer

This option turns on the Date/Time, Page number, Bates number, or Custom text and prints them in the specified header or footer location.

## Overlay

This option creates a watermark (or message) that overlays the content of your copy. You can choose between Urgent, Confidential, Copy, and Draft, or you can enter a custom message in the "Enter custom text" field. The word you pick will appear, faintly, in large print across each page.

**Note:** A custom overlay can also be created by your system support person. When a custom overlay is created, a button with an icon of that overlay will be available.

## Content

This option enhances copy quality. Choose from Text, Text/Photo, Photograph, or Printed Image.

- **Text**—Use this setting when copying original documents that are mostly text or line art.
- **Text/Photo**—Use this setting when copying original documents that are a mixture of text and graphics or pictures.
- **Photograph**—Use this setting when copying an original document that is a high-quality photograph or inkjet print.
- **Printed Image**—Use this setting when copying halftone photographs, documents printed on a laser printer, or pages from a magazine or newspaper.

## Advanced Duplex

This option controls whether the documents are one-sided or two-sided, what orientation your original documents have, and how your documents are bound.

**Note:** Some Advanced Duplex options may not be available on all printer models.

## Save as Shortcut

This option allows the current settings to be saved as a shortcut.

# Improving copy quality

Question	Tip
When should I use Text mode?	<ul style="list-style-type: none"><li>• Use text mode when text preservation is the main goal of the copy, and preserving images copied from the original document is not a concern.</li><li>• Text mode is recommended for receipts, carbon copy forms, and documents that contain only text or fine line art.</li></ul>
When should I use Text/Photo mode?	<ul style="list-style-type: none"><li>• Use Text/Photo mode when copying an original document that contains a mixture of text and graphics.</li><li>• Text/Photo mode is recommended for magazine articles, business graphics, and brochures.</li></ul>
When should I use Printed Image mode?	Use Printed Image mode when copying halftone photographs, graphics such as documents printed on a laser printer, or pages from a magazine or newspaper
When should I use Photograph mode?	Use Photograph mode when the original document is a high-quality photograph or inkjet print.

# E-mailing

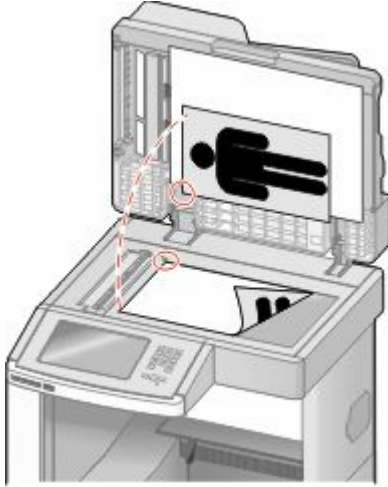
ADF	Scanner glass
 <p data-bbox="151 835 621 863">Use the ADF for multiple-page documents.</p>	 <p data-bbox="643 835 1438 919">Use the scanner glass for single pages, small items (such as postcards or photos), transparencies, photo paper, or thin media (such as magazine clippings).</p>

You can use the printer to e-mail scanned documents to one or more recipients. There are three ways to send an e-mail from the printer. You can type the e-mail address, use a shortcut number, or use the address book.

## Getting ready to e-mail

### Setting up the e-mail function

For e-mail to operate, it must be turned on in the printer configuration and have a valid IP address or gateway address. To set up the e-mail function:

- 1 Type the printer IP address into the address field of your Web browser.  
**Note:** If you do not know the IP address of the printer, then print a network setup page and locate the IP address in the TCP/IP section.
- 2 Click **Settings**.
- 3 Under Default Settings, click **E-mail/FTP Settings**.
- 4 Click **E-mail Settings**.
- 5 Click **Setup E-mail Server**.
- 6 Fill in the fields with the appropriate information.
- 7 Click **Add**.



## Configuring the e-mail settings

- 1 Type the printer IP address into the address field of your Web browser.  
**Note:** If you do not know the IP address of the printer, then print a network setup page and locate the IP address in the TCP/IP section.
- 2 Click **Settings**.
- 3 Click **E-mail/FTP Settings**.
- 4 Click **E-mail Settings**.
- 5 Fill in the fields with the appropriate information.
- 6 Click **Submit**.

## Creating an e-mail shortcut

### Creating an e-mail shortcut using the Embedded Web Server

- 1 Type the printer IP address into the address field of your Web browser.  
**Note:** If you do not know the IP address of the printer, then print a network setup page and locate the IP address in the TCP/IP section.
- 2 Click **Settings**.
- 3 Under Other Settings, click **Manage Shortcuts**.
- 4 Click **E-mail Shortcut Setup**.
- 5 Type a unique name for the recipient, and then enter the e-mail address.  
**Note:** If you are entering multiple addresses, then separate each address with a comma (,).
- 6 Select the scan settings (Format, Content, Color, and Resolution).
- 7 Enter a shortcut number, and then click **Add**.  
If you enter a number that is already in use, then you are prompted to select another number.

### Creating an e-mail shortcut using the touch screen

- 1 On the home screen, touch **E-mail**.
- 2 Type the recipient's e-mail address.  
To create a group of recipients, touch **Next address**, and then type the next recipient's e-mail address.
- 3 Touch **Save as Shortcut**.
- 4 Type a unique name for the shortcut, and then touch **Enter**.
- 5 Verify that the shortcut name and number are correct, and then touch **OK**.  
If the name or number is incorrect, then touch **Cancel**, and then reenter the information.

# E-mailing a document

## Sending an e-mail using the touch screen

- 1 Load an original document faceup, short edge first into the ADF or facedown on the scanner glass.  
**Note:** Do not load postcards, photos, small items, transparencies, photo paper, or thin media (such as magazine clippings) into the ADF. Place these items on the scanner glass.
- 2 If you are loading a document into the ADF, then adjust the paper guides.
- 3 On the home screen, touch **E-mail**.
- 4 Enter the e-mail address or shortcut number.  
To enter additional recipients, touch **Next Address**, and then enter the address or shortcut number you want to add.
- 5 Touch **E-mail It**.

## Sending an e-mail using a shortcut number

- 1 Load an original document faceup, short edge first into the ADF or facedown on the scanner glass.  
**Note:** Do not load postcards, photos, small items, transparencies, photo paper, or thin media (such as magazine clippings) into the ADF. Place these items on the scanner glass.
- 2 If you are loading a document into the ADF, then adjust the paper guides.
- 3 Press **#**, and then enter the shortcut number using the keypad.  
To enter additional recipients, press **Next address**, and then enter the address or shortcut number you want to add.
- 4 Touch **E-mail It**.

## Sending an e-mail using the address book

- 1 Load an original document faceup, short edge first into the ADF or facedown on the scanner glass.  
**Note:** Do not load postcards, photos, small items, transparencies, photo paper, or thin media (such as magazine clippings) into the ADF. Place these items on the scanner glass.
- 2 If you are loading a document into the ADF, adjust the paper guides.
- 3 On the home screen, touch **E-mail**.
- 4 Touch **Search Address Book**.
- 5 Enter the name or part of the name you are searching for, and then touch **Search**.
- 6 Touch the name that you want to add to the To: box.  
To enter additional recipients, press **Next address**, and then enter the address or shortcut number you want to add; or search the address book.
- 7 Touch **E-mail It**.

# Customizing e-mail settings

## Adding e-mail subject and message information

- 1 Load an original document faceup, short edge first into the ADF or facedown on the scanner glass.  
**Note:** Do not load postcards, photos, small items, transparencies, photo paper, or thin media (such as magazine clippings) into the ADF. Place these items on the scanner glass.
- 2 If you are loading a document into the ADF, adjust the paper guides.
- 3 On the home screen, touch **E-mail**.
- 4 Type an e-mail address.
- 5 Touch **Options**.
- 6 Touch **Subject**.
- 7 Type the e-mail subject.
- 8 Touch **Done**.
- 9 Touch **Message**.
- 10 Type an e-mail message.
- 11 Touch **Done**.
- 12 Touch **E-mail It**.

## Changing the output file type

- 1 Load an original document faceup, short edge first into the ADF or facedown on the scanner glass.  
**Note:** Do not load postcards, photos, small items, transparencies, photo paper, or thin media (such as magazine clippings) into the ADF. Place these items on the scanner glass.
- 2 If you are loading a document into the ADF, then adjust the paper guides.
- 3 On the home screen, touch **E-mail**.
- 4 Type an e-mail address.
- 5 Touch **Options**.
- 6 Touch the button that represents the file type you want to send.
  - **PDF**—Creates a single file with multiple pages, viewable with Adobe Reader. Adobe Reader is provided free by Adobe at [www.adobe.com](http://www.adobe.com).
  - **Secure PDF**—Creates an encrypted PDF file that protects the file contents from unauthorized access
  - **TIFF**—Creates multiple files or a single file. If Multi-page TIFF is turned off in the Settings menu of the Embedded Web Server, then TIFF saves one page in each file. The file size is usually larger than an equivalent JPEG.

- **JPEG**—Creates and attaches a separate file for each page of your original document, viewable by most Web browsers and graphics programs
- **XPS**—Creates a single XML Paper Specification (XPS) file with multiple pages, viewable using an Internet Explorer-hosted viewer and the .NET Framework, or by downloading a third party standalone viewer

## 7 Touch **E-mail It**.

**Note:** If you selected Encrypted PDF, then enter your password twice.

# Canceling an e-mail

- When using the ADF, touch **Cancel Job** while **Scanning...** appears.
- When using the scanner glass, touch **Cancel Job** while **Scanning...** appears or while **Scan the Next Page / Finish the Job** appears.

# Understanding e-mail options

## Original Size

This option opens a screen where you can choose the size of the documents you are going to e-mail.

- Touch a paper size button to select that size as the Original Size setting. The e-mail screen appears with your new setting displayed.
- When “Original Size” is set to Mixed Letter/Legal, you can scan an original document that contains mixed paper sizes.
- When “Original Size” is set to Auto Size Sense, the scanner automatically determines the size of the original document.

## Sides (Duplex)

This option informs the printer if the original document is simplex (printed on one side) or duplex (printed on both sides). This lets the scanner know what needs to be scanned for inclusion in the e-mail.

## Orientation

This option tells the printer whether the original document is in portrait or landscape orientation and then changes the Sides and Binding settings to match the original document orientation.

## Binding

Tells the printer whether the original document is bound on the long-edge or short-edge side.

## E-mail Subject

This option lets you enter a subject line for your e-mail. You can enter up to 255 characters.

## E-mail File Name

This option lets you customize the attachment file name.

## E-mail Message

This option lets you enter a message that will be sent with your scanned attachment.

## Resolution

Adjusts the output quality of your e-mail. Increasing the image resolution increases the e-mail file size and the time needed to scan your original document. Image resolution can be decreased to reduce the e-mail file size.

## Send As

This option sets the output (PDF, TIFF, JPEG or XPS) for the scanned image.

- **PDF**—Creates a single file with multiple pages, viewable with Adobe Reader. Adobe Reader is provided free by Adobe at [www.adobe.com](http://www.adobe.com).
- **Secure PDF**—Creates an encrypted PDF file that protects the file contents from unauthorized access
- **TIFF**—Creates multiple files or a single file. If Multi-page TIFF is turned off in the Settings menu of the Embedded Web Server, then TIFF saves one page in each file. The file size is usually larger than an equivalent JPEG.
- **JPEG**—Creates and attaches a separate file for each page of your original document, viewable by most Web browsers and graphics programs
- **XPS**—Creates a single XPS file with multiple pages, viewable using an Internet Explorer-hosted viewer and the .NET Framework, or by downloading a third party standalone viewer

## Content

This option tells the printer the original document type. Choose from Text, Text/Photo, or Photo. Color can be turned on or off with any of the Content choices. Content affects the quality and size of your e-mail.

- **Text**—Emphasizes sharp, black, high-resolution text against a clean, white background
- **Text/Photo**—Used when the original documents are a mixture of text and graphics or pictures
- **Photograph**—Tells the scanner to pay extra attention to graphics and pictures. This setting increases the time it takes to scan, but emphasizes a reproduction of the full dynamic range of tones in the original document. This increases the amount of information saved.
- **Color**—Sets the scan type and output for the e-mail. Color documents can be scanned and sent to an e-mail address.

## Advanced Options

Touching this button opens a screen where you change Advanced Imaging, Custom Job, Transmission Log, Scan Preview, Edge Erase, and Darkness settings.

- **Advanced Imaging**—Adjusts Background Removal, Contrast, Scan Edge to Edge, Shadow Detail, and Mirror Image before you copy the document
- **Custom Job (Job Build)**—Combines multiple scanning jobs into a single job
- **Transmission Log**—Prints the transmission log or transmission error log

- **Scan Preview**—Displays the first page of the image before it is included in the e-mail. When the first page is scanned, the scanning is paused and a preview image appears.
- **Edge Erase**—Eliminates smudges or information around the edges of a document. You can choose to eliminate an equal area around all four sides of the paper, or pick a particular edge. Edge Erase will erase whatever is within the area selected, leaving nothing on that portion of the scan.
- **Darkness**—Adjusts how light or dark your scanned e-mails will turn out

# Faxing

**Note:** Fax capabilities may not be available on all printer models.

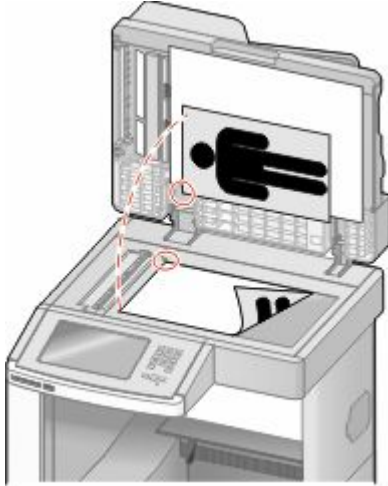
ADF	Scanner glass
 <p data-bbox="149 890 623 919">Use the ADF for multiple-page documents.</p>	 <p data-bbox="643 890 1442 982">Use the scanner glass for single pages, small items (such as postcards or photos), transparencies, photo paper, or thin media (such as magazine clippings).</p>

## Sending a fax

### Sending a fax using the printer control panel

- 1 Load an original document faceup, short edge first into the ADF or facedown on the scanner glass.  
**Note:** Do not load postcards, photos, small items, transparencies, photo paper, or thin media (such as magazine clippings) into the ADF. Place these items on the scanner glass.
- 2 If you are loading a document into the ADF, then adjust the paper guides.
- 3 On the home screen, touch **Fax**.
- 4 Enter the fax number or a shortcut using the touch screen or keypad.  
To add recipients, touch **Next Number**, and then enter the recipient's telephone number or shortcut number, or search the address book.  
**Note:** To place a dial pause within a fax number, press . The dial pause appears as a comma in the "Fax to" box. Use this feature if you need to dial an outside line first.
- 5 Touch **Fax It**.

## Sending a fax using the computer

Faxing from a computer lets you send electronic documents without leaving your desk. This gives you the flexibility of faxing documents directly from software programs.

**Note:** In order to perform this function from your computer, you must use the PostScript printer driver for your printer.

- 1 From your software program, click **File → Print**.
- 2 From the Print window, select your printer, and then click **Properties**.
- 3 Choose the **Other Options** tab, and then click **Fax**.
- 4 Click **OK**, and then click **OK** again.
- 5 On the Fax screen, type the name and number of the fax recipient.
- 6 Click **Send**.

## Creating shortcuts

### Creating a fax destination shortcut using the Embedded Web Server

Instead of entering the entire phone number of a fax recipient on the printer control panel each time you want to send a fax, you can create a permanent fax destination and assign a shortcut number. A shortcut can be created to a single fax number or a group of fax numbers.

- 1 Type the printer IP address into the address field of your Web browser.  
**Note:** If you do not know the IP address of the printer, then print a network setup page and locate the IP address in the TCP/IP section.
- 2 Click **Settings**.
- 3 Click **Manage Shortcuts**.  
**Note:** A password may be required. If you do not have an ID and password, get one from your system support person.
- 4 Click **Fax Shortcut Setup**.
- 5 Type a unique name for the shortcut, and then enter the fax number.  
To create a multiple-number shortcut, enter the fax numbers for the group.  
**Note:** Separate each fax number in the group with a semicolon (;).
- 6 Assign a shortcut number.  
If you enter a number that is already in use, then you are prompted to select another number.
- 7 Click **Add**.



## Creating a fax destination shortcut using the touch screen

- 1 Load an original document faceup, short edge first into the ADF or facedown on the scanner glass.  
**Note:** Do not load postcards, photos, small items, transparencies, photo paper, or thin media (such as magazine clippings) into the ADF. Place these items on the scanner glass.
- 2 If you are loading a document into the ADF, then adjust the paper guides.
- 3 On the home screen, touch **Fax**.
- 4 Enter the fax number.  
To create a group of fax numbers, touch **Next number**, and then enter the next fax number.
- 5 Touch **Save as Shortcut**.
- 6 Enter a name for the shortcut.
- 7 Verify that the shortcut name and number are correct, and then touch **OK**. If the name or number is incorrect, then touch **Cancel**, and then reenter the information.  
If you enter a number that is already in use, then you are prompted to select another number.
- 8 Touch **Fax It** to send the fax, or touch  to return to the home screen.

## Using shortcuts and the address book

### Using fax shortcuts

Fax shortcuts are just like the speed dial numbers on a telephone or fax machine. You can assign shortcut numbers when creating permanent fax destinations. Permanent fax destinations or speed dial numbers are created in the Manage Shortcuts link located under Settings on the Embedded Web Server. A shortcut number (1–99999) can contain a single recipient or multiple recipients. By creating a group fax shortcut with a shortcut number, you can quickly and easily fax broadcast information to an entire group.

- 1 Load an original document faceup, short edge first into the ADF or facedown on the scanner glass.  
**Note:** Do not place postcards, photos, small items, transparencies, photo paper, or thin media (such as magazine clippings) into the ADF. Place these items on the scanner glass.
- 2 If you are loading a document into the ADF, then adjust the paper guides.
- 3 Press , and then enter the shortcut number using the keypad.

### Using the address book

**Note:** If the address book feature is not enabled, then contact your system support person.

- 1 Load an original document faceup, short edge first into the ADF or facedown on the scanner glass.  
**Note:** Do not load postcards, photos, small items, transparencies, photo paper, or thin media (such as magazine clippings) into the ADF. Place these items on the scanner glass.
- 2 If you are loading a document into the ADF, then adjust the paper guides.
- 3 On the home screen, touch **Fax**.

- 4 Touch **Search Address Book**.
- 5 Using the virtual keyboard, type the name or part of the name of the person whose fax number you want to find. (Do not attempt to search for multiple names at the same time.)
- 6 Touch **Search**.
- 7 Touch the name to add it to the “Fax to” list.
- 8 Repeat steps 4 through 7 to enter additional addresses.
- 9 Touch **Fax It**.

## Customizing fax settings

### Changing the fax resolution

Adjusting the resolution setting changes the quality of the fax. Settings range from Standard (fastest speed) to Ultra Fine (slowest speed, best quality).

- 1 Load an original document faceup, short edge first into the ADF or facedown on the scanner glass.  
**Note:** Do not load postcards, photos, small items, transparencies, photo paper, or thin media (such as magazine clippings) into the ADF. Place these items on the scanner glass.
- 2 If you are loading a document into the ADF, then adjust the paper guides.
- 3 On the home screen, touch **Fax**.
- 4 Use the keypad to enter the fax number.
- 5 Touch **Options**.
- 6 From the Resolution area, touch the arrows to change to the resolution you want.
- 7 Touch **Fax It**.

### Making a fax lighter or darker

- 1 Load an original document faceup, short edge first into the ADF or facedown on the scanner glass.  
**Note:** Do not load postcards, photos, small items, transparencies, photo paper, or thin media (such as magazine clippings) into the ADF. Place these items on the scanner glass.
- 2 If you are loading a document into the ADF, then adjust the paper guides.
- 3 On the home screen, touch **Fax**.
- 4 Use the keypad to enter the fax number.
- 5 Touch **Options**.
- 6 From the Darkness area, touch the arrows to adjust the darkness of the fax.
- 7 Touch **Fax It**.

## Sending a fax at a scheduled time

- 1 Load an original document faceup, short edge first into the ADF or facedown on the scanner glass.  
**Note:** Do not load postcards, photos, small items, transparencies, photo paper, or thin media (such as magazine clippings) into the ADF. Place these items on the scanner glass.
- 2 If you are loading a document into the ADF, then adjust the paper guides.
- 3 On the home screen, touch **Fax**.
- 4 Enter the fax number using the numbers on the touch screen or keypad.
- 5 Touch **Options**.
- 6 Touch **Advanced Options**.
- 7 Touch **Delayed Send**.  
**Note:** If Fax Mode is set to Fax Server, the Delayed Send button will not appear. Faxes waiting for transmission are listed in the Fax Queue.
- 8 Touch the arrows to adjust the time the fax will be transmitted.  
The time is increased or decreased in increments of 30 minutes. If the current time is shown, the left arrow is unavailable.
- 9 Touch **Done**.
- 10 Touch **Fax it**.  
**Note:** The document is scanned and then faxed at the scheduled time.

## Viewing a fax log

- 1 Type the printer IP address into the address field of your Web browser.  
**Note:** If you do not know the IP address of the printer, then print a network setup page and locate the IP address in the TCP/IP section.
- 2 Click **Settings**.
- 3 Click **Reports**.
- 4 Click **Fax Job Log** or **Fax Call Log**.

## Blocking junk faxes

- 1 Type the printer IP address into the address field of your Web browser.  
**Note:** If you do not know the IP address of the printer, then print a network setup page and locate the IP address in the TCP/IP section.
- 2 Click **Settings**.
- 3 Click **Fax Settings**.
- 4 Click **Analog Fax Setup**.

- 5 Click the **Block No Name Fax** option.

This option blocks all incoming faxes that have a private caller ID or no fax station name.

- 6 In the Banned Fax List field, enter the phone numbers or fax station names of specific fax callers you want to block.

## Canceling an outgoing fax

### Canceling a fax while the original documents are still scanning

- When using the ADF, touch **Cancel Job** while **Scanning...** appears.
- When using the scanner glass, touch **Cancel Job** while **Scanning...** appears or while **Scan the Next Page / Finish the Job** appears.

### Canceling a fax after the original documents have been scanned to memory

- 1 On the home screen, touch **Cancel Jobs**.

The Cancel Jobs screen appears.

- 2 Touch the job or jobs you want to cancel.

Only three jobs appear on the screen; touch the down arrow until the job you want appears, and then touch the job you want to cancel.

- 3 Touch **Delete Selected Jobs**.

The Deleting Selected Jobs screen appears, the selected jobs are deleted, and then the home screen appears.

## Understanding fax options

### Original Size

This option opens a screen where you can choose the size of the documents you are going to fax.

- Touch a paper size button to select that size as the Original Size setting. The fax screen appears with your new setting displayed.
- When Original Size is set to Mixed Letter/Legal, you can scan an original document that contains mixed paper sizes.
- When "Original Size" is set to Auto Size Sense, the scanner automatically determines the size of the original document.

## Content

This option tells the printer the original document type. Choose from Text, Text/Photo, or Photograph. Color can be turned on or off with any of the Content choices. Content affects the quality and size of your scan.

- **Text**—Emphasizes sharp, black, high-resolution text against a clean, white background
- **Text/Photo**—Used when the original documents are a mixture of text and graphics or pictures
- **Photograph**—Tells the scanner to pay extra attention to graphics and pictures. This setting increases the time it takes to scan, but emphasizes a reproduction of the full dynamic range of tones in the original document. This increases the amount of information saved.
- **Color**—Sets the scan type and output for the fax. Color documents can be scanned and sent to a fax destination.

## Sides (Duplex)

This option informs the printer if the original document is simplex (printed on one side) or duplex (printed on both sides). This lets the scanner know what needs to be scanned for inclusion in the fax.

## Resolution

This options increases how closely the scanner examines the document you want to fax. If you are faxing a photo, a drawing with fine lines, or a document with very small text, increase the Resolution setting. This will increase the amount of time required for the scan and will increase the quality of the fax output.

- **Standard**—Suitable for most documents
- **Fine**—Recommended for documents with small print
- **Super fine**—Recommended for original documents with fine detail
- **Ultra fine**—Recommended for documents with pictures or photos

## Darkness

This option adjusts how light or dark your faxes will turn out in relation to the original document.

## Advanced Options

Touching this button opens a screen where you can change Delayed Send, Advanced Imaging, Custom Job, Transmission Log, Scan Preview, Edge Erase, and Advanced Duplex settings.

- **Delayed Send**—Lets you send a fax at a later time or date. After setting up your fax, touch **Delayed Send**, enter the time and date you would like to send your fax, and then touch **Done**. This setting can be especially useful in sending information to fax lines that are not readily available during certain hours, or when transmission times are cheaper.

**Note:** If the printer is turned off when the delayed fax is scheduled to be sent, the fax is sent the next time the printer is turned on.

- **Advanced Imaging**—Adjusts Background Removal, Contrast, Scan Edge to Edge, Shadow Detail, and Mirror Image before you fax the document
- **Custom Job (Job Build)**—Combines multiple scanning jobs into a single job
- **Transmission Log**—Prints the transmission log or transmission error log
- **Scan Preview**—Displays the image before it is included in the fax. When the first page is scanned, the scanning is paused, and a preview image appears.

- **Edge Erase**—Eliminates smudges or information around the edges of a document. You can choose to eliminate an equal area around all four sides of the paper, or pick a particular edge. Edge Erase will erase whatever is within the area selected, leaving nothing on that portion of the scan.
- **Advanced Duplex**—Controls how many sides and what orientation an original document has, and whether original documents are bound along the long edge or the short edge

**Note:** Some Advanced Duplex options may not be available on all printer models.

## Improving fax quality

Question	Tip
When should I use Text mode?	<ul style="list-style-type: none"> <li>• Use Text mode when text preservation is the main goal of the fax, and preserving images copied from the original document is not a concern.</li> <li>• Text mode is recommended for faxing receipts, carbon copy forms, and documents that contain only text or fine line art.</li> </ul>
When should I use Text/Photo mode?	<ul style="list-style-type: none"> <li>• Use Text/Photo mode when faxing an original document that contains a mixture of text and graphics.</li> <li>• Text/Photo mode is recommended for magazine articles, business graphics, and brochures.</li> </ul>
When should I use Photo mode?	Use Photo mode when faxing photos printed on a laser printer or taken from a magazine or newspaper.

## Holding and forwarding faxes

### Holding faxes

This option lets you hold received faxes from printing until they are released. Held faxes can be released manually or at a scheduled day or time.

- 1 Type the printer IP address into the address field of your Web browser.

**Note:** If you do not know the IP address of the printer, then print a network setup page and locate the IP address in the TCP/IP section.

- 2 Click **Settings**.
- 3 Click **Fax Settings**.
- 4 Click **Analog Fax Setup**.
- 5 Click **Holding Faxes**.
- 6 Enter a password in the Print Faxes Password box.
- 7 From the Held Fax Mode menu, select one of the following:
  - **Off**
  - **Always On**
  - **Manual**
  - **Scheduled**

- 8** If you selected **Scheduled**, then continue with the following steps. Otherwise, go to step 9.
  - a** Click **Fax Holding Schedule**.
  - b** From the Action menu, select **Hold faxes**.
  - c** From the Time menu, select the time you want the held faxes released.
  - d** From the Day(s) menu, select the day you want the held faxes released.
- 9** Click **Add**.

## Forwarding a fax

This option lets you print and forward received faxes to a fax number, e-mail address, FTP site, or LDSS.

- 1** Type the printer IP address into the address field of your Web browser.

**Note:** If you do not know the IP address of the printer, then print a network setup page and locate the IP address in the TCP/IP section.
- 2** Click **Settings**.
- 3** Click **Fax Settings**.
- 4** Click **Analog Fax Setup**.
- 5** From the Fax Forwarding menu, select one of the following:
  - **Print**
  - **Print and Forward**
  - **Forward**
- 6** From the "Forward to" menu, select one of the following:
  - **Fax**
  - **E-mail**
  - **FTP**
  - **LDSS**
  - **eSF**
- 7** Click inside the Forward to Shortcut box, and then enter the shortcut number where you want the fax forwarded.

**Note:** The shortcut number must be a valid shortcut number for the setting that was selected in the "Forward to" menu.
- 8** Click **Submit**.

# Scanning to an FTP address

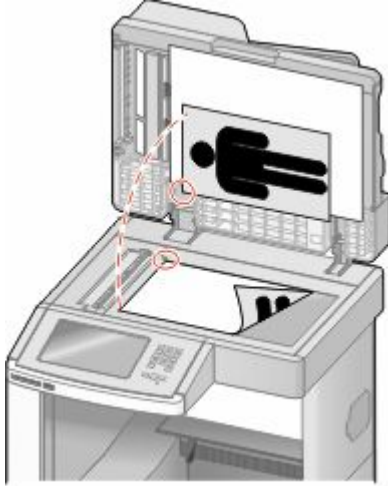
ADF	Scanner glass
 <p data-bbox="147 835 625 863">Use the ADF for multiple-page documents.</p>	 <p data-bbox="639 835 1442 926">Use the scanner glass for single pages, small items (such as postcards or photos), transparencies, photo paper, or thin media (such as magazine clippings).</p>

The scanner lets you scan documents directly to a *File Transfer Protocol (FTP)* server. Only one FTP address may be sent to the server at a time.

Once an FTP destination has been configured by your system support person, the name of the destination becomes available as a shortcut number, or it is listed as a profile under the Held Jobs icon. An FTP destination could also be another PostScript printer; for example, a color document can be scanned and then sent to a color printer. Sending a document to an FTP server is similar to sending a fax. The difference is that you are sending the information over your network instead of over the phone line.

## Scanning to an FTP address

### Scanning to an FTP address using the keypad

- 1 Load an original document faceup, short edge first into the ADF or facedown on the scanner glass.  
**Note:** Do not load postcards, photos, small items, transparencies, photo paper, or thin media (such as magazine clippings) into the ADF. Place these items on the scanner glass.
- 2 If you are loading a document into the ADF, adjust the paper guides.
- 3 On the home screen, touch **FTP**.
- 4 Type the FTP address.
- 5 Touch **Send It**.



## Scanning to an FTP address using a shortcut number

- 1 Load an original document faceup, short edge first into the ADF or facedown on the scanner glass.  
**Note:** Do not load postcards, photos, small items, transparencies, photo paper, or thin media (such as magazine clippings) into the ADF. Place these items on the scanner glass.
- 2 If you are loading a document into the ADF, then adjust the paper guides.
- 3 Press #, and then enter the FTP shortcut number.
- 4 Touch **Send It**.

## Scanning to an FTP address using the address book

- 1 Load an original document faceup, short edge first into the ADF or facedown on the scanner glass.  
**Note:** Do not load postcards, photos, small items, transparencies, photo paper, or thin media (such as magazine clippings) into the ADF. Place these items on the scanner glass.
- 2 If you are loading a document into the ADF, adjust the paper guides.
- 3 On the home screen, touch **FTP**.
- 4 Touch **Search Address Book**.
- 5 Type the name or part of the name you are searching for, and then touch **Search**.
- 6 Touch the name that you want to add to the To: field.
- 7 Touch **Send It**.

## Creating shortcuts

Instead of entering the entire FTP site address on the control panel each time you want to send a document to an FTP server, you can create a permanent FTP destination and assign a shortcut number. There are two methods for creating shortcut numbers: using a computer or using the printer touch screen.

### Creating an FTP shortcut using the Embedded Web Server

- 1 Type the printer IP address into the address field of your Web browser.  
**Note:** If you do not know the IP address of the printer, then print a network setup page and locate the IP address in the TCP/IP section.
- 2 Click **Settings**.
- 3 Under Other Settings, click **Manage Shortcuts**.  
**Note:** A password may be required. If you do not have an ID and password, get one from your system support person.
- 4 Click **FTP Shortcut Setup**.
- 5 Enter the appropriate information into the boxes.

**6** Enter a shortcut number.

If you enter a number that is already in use, then you are prompted to select another number.

**7** Click **Add**.

## Creating an FTP shortcut using the touch screen

**1** On the home screen, touch **FTP**.

**2** Type the address of the FTP site.

**3** Touch **Save as Shortcut**.

**4** Enter a name for the shortcut.

**5** Verify that the shortcut name and number are correct, and then touch **OK**. If the name or number is incorrect, then touch **Cancel**, and then reenter the information.

If you enter a number that is already in use, then you are prompted to select another number.

**6** Touch **Send It** to start the scan, or touch  to return to the home screen.

## Understanding FTP options

### Original Size

This option opens a screen where you can choose the size of the documents you are going to copy.

- Touch a paper size button to select that size as the Original Size setting. The FTP screen appears with your new setting displayed.
- When "Original Size" is set to Mixed Letter/Legal, you can scan an original document that contains mixed paper sizes.
- When "Original Size" is set to Auto Size Sense, the scanner automatically determines the size of the original document.

### Sides (Duplex)

This option informs the printer if the original document is simplex (printed on one side) or duplex (printed on both sides). This lets the scanner know what needs to be scanned for inclusion in the document.

### Orientation

This option tells the printer whether the original document is in portrait or landscape orientation and then changes the Sides and Binding settings to match the original document orientation.

### Binding

Tells the printer whether the original document is bound on the long-edge or short-edge side.

## Resolution

This option adjusts the output quality of your file. Increasing the image resolution increases the file size and the time needed to scan your original document. Image resolution can be decreased to reduce the file size.

## Send As

This option sets the output (PDF, TIFF, JPEG or XPS) for the scanned image.

- **PDF**—Creates a single file with multiple pages, viewable with Adobe Reader. Adobe Reader is provided free by Adobe at [www.adobe.com](http://www.adobe.com).
- **Secure PDF**—Creates an encrypted PDF file that protects the file contents from unauthorized access
- **TIFF**—Creates multiple files or a single file. If Multi-page TIFF is turned off in the Settings menu of the Embedded Web Server, then TIFF saves one page in each file. The file size is usually larger than an equivalent JPEG.
- **JPEG**—Creates and attaches a separate file for each page of your original document, viewable by most Web browsers and graphics programs
- **XPS**—Creates a single XPS file with multiple pages, viewable using an Internet Explorer-hosted viewer and the .NET Framework, or by downloading a third party standalone viewer

## Content

This option tells the printer the original document type. Choose from Text, Text/Photo, or Photo. Color can be turned on or off with any of the Content choices. Content affects the quality and size of your FTP file.

- **Text**—Emphasize sharp, black, high-resolution text against a clean, white background
- **Text/Photo**—Used when the original documents are a mixture of text and graphics or pictures
- **Photograph**—Tells the scanner to pay extra attention to graphics and pictures. This setting increases the time it takes to scan, but emphasizes a reproduction of the full dynamic range of tones in the original document. This increases the amount of information saved.
- **Color**—Sets the scan type and output for the FTP file. Color documents can be scanned and sent to an FTP site, computer, e-mail address, or the printer.

## Advanced Options

Touching this button opens a screen where you can change Advanced Imaging, Custom Job, Transmission Log, Scan Preview, Edge Erase, and Darkness settings.

- **Advanced Imaging**—Adjusts image output settings before you scan the document
  - **Background Removal**—Adjusts the white portion of the output. Click the arrow buttons to increase or decrease the white portion.
  - **Color Dropout**—Color dropout is used for form Optical Character Recognition (OCR) processing. Selecting a color eliminates the color from a form, enabling improved OCR capabilities.
  - **Contrast**—Click the arrow buttons to increase or decrease the contrast.
  - **JPEG Quality**—Click the arrow buttons to increase or decrease the image compression.
  - **Mirror Image**—Select this box to create a mirror image scan.
  - **Negative Image**—Select this box to create a negative image scan.
  - **Shadow Detail**—Click the arrow buttons to increase or decrease the visible detail in the shadows.

- **Scan edge to edge**—Select this box to scan edge to edge.
- **Sharpness**—Click the arrow buttons to increase or decrease the sharpness.
- **Custom Job (Job Build)**—Combines multiple scanning jobs into a single job
- **Transmission Log**—Prints the transmission log or transmission error log
- **Scan Preview**—Displays the first page of an image before it is included in the FTP file. When the first page is scanned, the scanning is paused and a preview image appears.
- **Edge Erase**—Eliminates smudges or information around the edges of a document. You can choose to eliminate an equal area around all four sides of the paper, or pick a particular edge. Edge Erase will erase whatever is within the area selected, leaving nothing on that portion of the scan.
- **Darkness**—Adjusts how light or dark your scanned documents will turn out

## Improving FTP quality

Question	Tip
When should I use Text mode?	<ul style="list-style-type: none"> <li>• Use Text mode when text preservation is the main goal of sending a document to an FTP site, and preserving images copied from the original document is not a concern.</li> <li>• Text mode is recommended for receipts, carbon copy forms, and documents that only contain text or fine line art.</li> </ul>
When should I use Text/Photo mode?	<ul style="list-style-type: none"> <li>• Use Text/Photo mode when sending a document to an FTP site that contains a mixture of text and graphics.</li> <li>• Text/Photo mode is recommended for magazine articles, business graphics, and brochures.</li> </ul>
When should I use Photo mode?	Use Photo mode when the original document is composed mostly of photos printed on a laser printer or taken from a magazine or newspaper.

# Scanning to a computer or flash drive

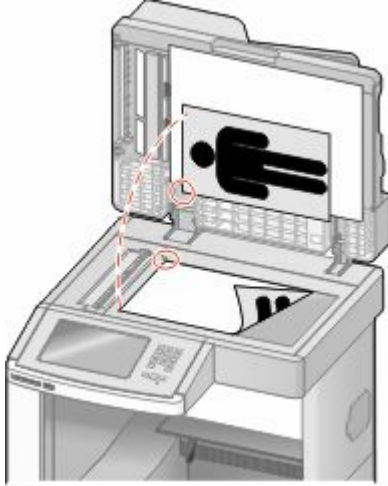
ADF	Scanner glass
 <p data-bbox="149 835 623 863">Use the ADF for multiple-page documents.</p>	 <p data-bbox="639 835 1438 926">Use the scanner glass for single pages, small items (such as postcards or photos), transparencies, photo paper, or thin media (such as magazine clippings).</p>

The scanner lets you scan documents directly to a computer or a flash drive. The computer does not have to be directly connected to the printer for you to receive Scan to PC images. You can scan the document back to the computer over the network by creating a scan profile on the computer and then downloading the profile to the printer.

## Scanning to a computer

- 1 Type the printer IP address into the address field of your Web browser.

**Note:** If you do not know the IP address of the printer, then print a network setup page and locate the IP address in the TCP/IP section.

- 2 Click **Scan Profile**.
- 3 Click **Create**.
- 4 Select your scan settings, and then click **Next**.
- 5 Select a location on your computer where you want to save the scanned output file.
- 6 Enter a scan name.  
The scan name is the name that appears in the Scan Profile list on the display.
- 7 Click **Submit**.
- 8 Review the instructions on the Scan Profile screen.

A shortcut number was automatically assigned when you clicked Submit. You can use this shortcut number when you are ready to scan your documents.

- a Load an original document faceup, short edge first into the ADF or facedown on the scanner glass.

**Note:** Do not load postcards, photos, small items, transparencies, photo paper, or thin media (such as magazine clippings) into the ADF. Place these items on the scanner glass.

- b If you are loading a document into the ADF, then adjust the paper guides.

- c Press **#**, and then enter the shortcut number using the keypad, or touch **Held Jobs** on the home screen, and then touch **Profiles**.

- d After you enter the shortcut number, the scanner scans and sends the document to the directory or program you specified. If you touched **Profiles** on the home screen, then locate your shortcut on the list.

- 9 Return to the computer to view the file.

The output file is saved in the location you specified or launched in the program you specified.

## Scanning to a flash drive

- 1 Load an original document faceup, short edge first into the ADF or facedown on the scanner glass.

**Note:** Do not load postcards, photos, small items, transparencies, photo paper, or thin media (such as magazine clippings) into the ADF. Place these items on the scanner glass.

- 2 If you are loading a document into the ADF, then adjust the paper guides.

- 3 Insert the flash drive into the USB port on the front of the printer.

The Held Jobs screen appears.

- 4 Touch **Scan to USB drive**.

- 5 Select the scan settings.

- 6 Touch **Scan It**.

## Understanding scan profile options

### Quick Setup

This option lets you select preset formats or customize the scan job settings. You can select one of these settings:

Custom	Photo - Color JPEG
Text - BW PDF	Photo - Color TIFF
Text - BW TIFF	Text/Photo - BW PDF Text/Photo - Color PDF

To customize the scan job settings, from the Quick Setup menu, select **Custom**. Then change the scan settings as needed.

## Format Type

This option sets the output (PDF, JPEG, TIFF, SECURE PDF, or XPS) for the scanned image.

- **PDF**—Creates a single file with multiple pages, viewable with Adobe Reader. Adobe Reader is provided free by Adobe at [www.adobe.com](http://www.adobe.com).
- **JPEG**—Creates and attaches a separate file for each page of your original document, viewable by most Web browsers and graphics programs
- **TIFF**—Creates multiple files or a single file. If Multi-page TIFF is turned off in the Settings menu of the Embedded Web Server, then TIFF saves one page in each file. The file size is usually larger than an equivalent JPEG.
- **Secure PDF**—Creates an encrypted PDF file that protects the file contents from unauthorized access
- **XPS**—Creates a single XPS file with multiple pages, viewable using an Internet Explorer-hosted viewer and the .NET Framework, or by downloading a third party standalone viewer

## Compression

This option sets the format used to compress the scanned output file.

## Default Content

This option tells the printer the original document type. Choose from Text, Text/Photo, or Photo. Content affects the quality and size of your scanned file.

**Text**—Emphasizes sharp, black, high-resolution text against a clean, white background

**Text/Photo**—Used when the original documents are a mixture of text and graphics or pictures

**Photo**—Tells the scanner to pay extra attention to graphics and pictures. This setting increases the time it takes to scan, but emphasizes a reproduction of the full dynamic range of tones in the original document. This increases the amount of information saved.

## Color

This option tells the printer the color of the original documents. You can select Gray, BW (Black and White), or Color.

## Original Size

This option sets the size of the documents you are going to scan. When Original Size is set to Mixed Sizes, you can scan an original document that contains mixed paper sizes (letter- and legal-size pages).

## Orientation

This option tells the printer whether the original document is in portrait or landscape orientation and then changes the Sides and Binding settings to match the original document orientation.

## Sides (Duplex)

This option informs the printer if your original document is simplex (printed on one side) or duplex (printed on both sides). This lets the scanner know what needs to be scanned for inclusion in the document.

## Darkness

This option adjusts how light or dark your scanned documents will turn out in relation to the original document.

## Resolution

This option adjusts the output quality of your file. Increasing the image resolution increases the file size and the time needed to scan your original document. Image resolution can be decreased to reduce the file size.

## Advanced Imaging

This option lets you adjust Background Removal, Contrast, Shadow Detail, Sharpness, and Color Dropout before you scan the document. It also lets you Scan edge to edge, as a Mirror Image, or as a Negative Image.

- **Background Removal**—Adjusts the white portion of the output. Click the arrow buttons to increase or decrease the white portion.
- **Contrast**—Click the arrow buttons to increase or decrease the contrast.
- **Shadow Detail**—Click the arrow buttons to increase or decrease the visible detail in the shadows.
- **Sharpness**—Click the arrow buttons to increase or decrease the sharpness.
- **Color Dropout**—Color dropout is used for form Optical Character Recognition (OCR) processing. Selecting a color eliminates the color from a form, enabling improved OCR capabilities.
- **Color Dropout Threshold**—Click the arrow buttons to increase or decrease the amount of color dropout.
- **Scan edge to edge**—Select this box to scan edge to edge.
- **Mirror Image**—Select this box to create a mirror image scan.
- **Negative Image**—Select this box to create a negative image scan.

## Improving scan quality

Question	Tip
When should I use Text mode?	<ul style="list-style-type: none"><li>• Use Text mode when text preservation is the main goal of the scan, and preserving images copied from the original document is not a concern.</li><li>• Text mode is recommended for receipts, carbon copy forms, and documents that only contain text or fine line art.</li></ul>
When should I use Text/Photo mode?	<ul style="list-style-type: none"><li>• Use Text/Photo mode when scanning an original document that contains a mixture of text and graphics.</li><li>• Text/Photo mode is recommended for magazine articles, business graphics, and brochures.</li></ul>
When should I use Photo mode?	Use Photo mode when scanning photos printed on a laser printer or taken from a magazine or newspaper.



# Printing

This chapter covers printing, printer reports, and job cancelation. Selection and handling of paper and specialty media can affect how reliably documents print. For more information, see “Avoiding jams” on page 138 and “Storing paper” on page 86.

## Printing a document

- 1 Load paper into a tray or feeder.
- 2 From the printer control panel Paper menu, set the Paper Type and Paper Size to match the loaded paper.
- 3 Do one of the following:

### For Windows users

- a With a document open, click **File** → **Print**.
- b Click **Properties**, **Preferences**, **Options**, or **Setup**, and then adjust the settings as needed.

**Note:** To print on a specific size or type of paper, adjust the paper size or type settings to match the loaded paper, or select the appropriate tray or feeder.

- c Click **OK**, and then click **Print**.

### For Macintosh users

- a Customize the settings as needed in the Page Setup dialog:
  - 1 With a document open, choose **File** > **Page Setup**.
  - 2 Choose a paper size or create a custom size to match the loaded paper.
  - 3 Click **OK**.

- b Customize the settings as needed in the Print dialog:
  - 1 With a document open, choose **File** > **Print**.  
If necessary, click the disclosure triangle to see more options.
  - 2 From the Print dialog and pop-up menus, adjust the settings as needed.

**Note:** To print on a specific paper type, adjust the paper type setting to match the loaded paper, or select the appropriate tray or feeder.

- 3 Click **Print**.

## Printing on specialty media

### Tips on using letterhead

- Use letterhead designed specifically for laser printers.
- Print samples on the letterhead being considered for use before buying large quantities.
- Before loading letterhead, fan the stack to prevent sheets from sticking together.

- Page orientation is important when printing on letterhead. For information on how to load letterhead, see:
  - “Loading the standard or optional 250-sheet or 550-sheet tray” on page 71
  - “Loading the 2000-sheet tray” on page 74
  - “Loading the multipurpose feeder” on page 78

## Tips on using transparencies

Print samples on the transparencies being considered for use before buying large quantities.

When printing on transparencies:

- Feed transparencies from a 250-sheet tray, a 550-sheet tray, or the multipurpose feeder.
- Use transparencies designed specifically for laser printers. Check with the manufacturer or vendor to ensure transparencies are able to withstand temperatures up to 230°C (446°F) without melting, discoloring, offsetting, or releasing hazardous emissions.
- Use transparencies that are 138–146 g/m<sup>2</sup> (37–39 lb. bond) in weight.
- To prevent print quality problems, avoid getting fingerprints on the transparencies.
- Before loading transparencies, fan the stack to prevent sheets from sticking together.

## Tips on using envelopes

Print samples on the envelopes being considered for use before buying large quantities.

When printing on envelopes:

- Feed envelopes from the multipurpose feeder or the optional envelope feeder.
- Set the Paper Type to Envelope, and select the envelope size.
- Use envelopes designed specifically for laser printers. Check with the manufacturer or vendor to ensure the envelopes can withstand temperatures up to 230°C (446°F) without sealing, wrinkling, curling excessively, or releasing hazardous emissions.
- For the best performance, use envelopes made from 90 g/m<sup>2</sup> (24 lb bond) paper. Use up to 105 g/m<sup>2</sup> (28 lb bond) weight for envelopes as long as the cotton content is 25% or less. All-cotton envelopes must not exceed 90 g/m<sup>2</sup> (24 lb bond) weight.
- Use only new envelopes.
- To optimize performance and minimize jams, do not use envelopes that:
  - Have excessive curl or twist
  - Are stuck together or damaged in any way
  - Have windows, holes, perforations, cutouts, or embossing
  - Have metal clasps, string ties, or folding bars
  - Have an interlocking design
  - Have postage stamps attached
  - Have any exposed adhesive when the flap is in the sealed or closed position
  - Have bent corners
  - Have rough, cockle, or laid finishes
- Adjust the width guide to fit the width of the envelopes.

**Note:** A combination of high humidity (over 60%) and the high printing temperature may wrinkle or seal envelopes.

## Tips on using labels

Print samples on the labels being considered for use before buying large quantities.

**Note:** Single-sided paper labels designed for laser printers are supported for occasional use: no more than 20 pages of labels a month. Vinyl, pharmacy, and dual-web labels are not supported.

When printing on labels:

- Feed labels from a 250-sheet tray, a 550-sheet tray, or the multipurpose feeder.
- Use labels designed specifically for laser printers. Check with the manufacturer or vendor to verify that:
  - The labels can withstand temperatures up to 230°C (446°F) without sealing, excessive curling, wrinkling, or releasing hazardous emissions.
  - Label adhesives, face sheet (printable stock), and topcoats can withstand up to 25 psi (172 kPa) pressure without delaminating, oozing around the edges, or releasing hazardous fumes.
- Do not use labels with slick backing material.
- Use full label sheets. Partial sheets may cause labels to peel off during printing, resulting in a jam. Partial sheets also contaminate the printer and the cartridge with adhesive, and could void the printer and cartridge warranties.
- Do not use labels with exposed adhesive.
- Do not print within 1 mm (0.04 in.) of the edge of the label, of the perforations, or between die-cuts of the label.
- Be sure adhesive backing does not reach to the sheet edge. Zone coating of the adhesive at least 1 mm (0.04 in.) away from edges is recommended. Adhesive material contaminates the printer and could void the warranty.
- If zone coating of the adhesive is not possible, remove a 1.6-mm (0.06-in.) strip on the leading and driver edge, and use a non-oozing adhesive.
- Portrait orientation works best, especially when printing bar codes.

## Tips on using card stock

Card stock is heavy, single-ply specialty media. Many of its variable characteristics, such as moisture content, thickness, and texture, can significantly impact print quality. Print samples on the card stock being considered for use before buying large quantities.

When printing on card stock:

- Feed card stock from a 250-sheet tray, a 550-sheet tray, or the multipurpose feeder.
- Make sure the Paper Type is Card Stock.
- Select the appropriate Paper Texture setting.
- Be aware that preprinting, perforation, and creasing may significantly affect the print quality and cause jams or other paper handling problems.
- Check with the manufacturer or vendor to ensure the card stock can withstand temperatures up to 230°C (446°F) without releasing hazardous emissions.
- Do not use preprinted card stock manufactured with chemicals that may contaminate the printer. Preprinting introduces semi-liquid and volatile components into the printer.
- Use grain short card stock when possible.

# Printing confidential and other held jobs

## Holding jobs in the printer

When sending a job to the printer, you can specify that you want the printer to hold the job in memory until you start the job from the printer control panel. All print jobs that can be initiated by the user at the printer are called *held jobs*.

**Note:** Confidential, Verify, Reserve, and Repeat print jobs may be deleted if the printer requires extra memory to process additional held jobs.

Job type	Description
Confidential	When you send a Confidential print job to the printer, you must create a PIN from the computer. The PIN must be four digits using the numbers 0–9. The job is held in printer memory until you enter the PIN from the printer control panel and choose to print or delete the job.
Verify	When you send a Verify print job, the printer prints one copy and holds the remaining copies in printer memory. Verify lets you examine the first copy to see if it is satisfactory before printing the remaining copies. Once all copies are printed, the job is automatically deleted from printer memory.
Reserve	When you send a Reserve print job, the printer does not print the job immediately. It stores the job in memory so you can print the job later. The job is held in memory until you delete it from the Held Jobs menu.
Repeat	When you send a Repeat print job, the printer prints all requested copies of the job <i>and</i> stores the job in memory so you can print additional copies later. You can print additional copies as long as the job remains stored in memory.

Other types of held jobs include:

- Profiles from various sources
- Forms from a kiosk
- Bookmarks
- Jobs not printed, which are called *parked jobs*

## Printing confidential and other held jobs from Windows

**Note:** Confidential and Verify print jobs are automatically deleted from memory after they print. Repeat and Reserve jobs continue to be held in the printer until you choose to delete them.

- 1 With a document open, click **File → Print**.
- 2 Click **Properties, Preferences, Options, or Setup**.
- 3 Click **Other Options**, and then click **Print and Hold**.
- 4 Select your job type (Confidential, Reserve, Repeat, or Verify), and then assign a user name. For a confidential job, also enter a four-digit PIN.
- 5 Click **OK** or **Print**, and then go to the printer to release the job.
- 6 On the home screen, touch **Held jobs**.

- 7 Touch your user name.  
**Note:** A maximum of 500 results can be displayed for held jobs. If your name does not appear, touch the down arrow until your name appears, or touch **Search Held Jobs** if there are a large number of held jobs in the printer.
- 8 Touch **Confidential Jobs**.
- 9 Enter your PIN.
- 10 Touch the job you want to print.
- 11 Touch **Print**, or touch the arrows to increase or decrease the number of copies, and then touch **Print**.

## Printing confidential and other held jobs from a Macintosh computer

**Note:** Confidential and Verify print jobs are automatically deleted from memory after they print. Repeat and Reserve jobs continue to be held in the printer until you choose to delete them.

- 1 With a document open, choose **File > Print**.  
If necessary, click the disclosure triangle to see more options.
- 2 From the print options or Copies & Pages pop-up menu, choose **Job Routing**.
- 3 Select your job type (Confidential, Reserve, Repeat, or Verify), and then assign a user name. For a confidential job, also enter a four-digit PIN.
- 4 Click OK or Print, and then go to the printer to release the job.
- 5 On the home screen, touch **Held jobs**.
- 6 Touch your user name.  
**Note:** A maximum of 500 results can be displayed for held jobs. If your name does not appear, touch the down arrow until your name appears, or touch **Search Held Jobs** if there are a large number of held jobs in the printer.
- 7 Touch **Confidential Jobs**.
- 8 Enter your PIN.
- 9 Touch the job you want to print.
- 10 Touch **Print**, or touch the arrows to increase or decrease the number of copies, and then touch **Print**.

# Printing from a flash drive

A USB port is located on the printer control panel. Insert a flash drive to print supported file types. Supported file types include: .pdf, .gif, .jpeg, .jpg, .bmp, .png, .tiff, .tif, .pcx, and .dcx.

Many flash drives are tested and approved for use with the printer.

## Notes:

- Hi-Speed flash drives must support the Full-speed standard. Flash drives supporting only USB Low-speed capabilities are not supported.
- USB devices must support the FAT (*File Allocation Tables*) system. Devices formatted with NTFS (*New Technology File System*) or any other file system are not supported.
- If selecting an encrypted .pdf file, then enter the file password from the printer control panel.
- Before printing an encrypted .pdf file, enter the file password from the printer control panel.
- You cannot print files for which you do not have printing permissions.

To print from a flash drive:

- 1 Make sure the printer is on and **Ready** appears.
- 2 Insert a flash drive into the USB port.



## Notes:

- If you insert the flash drive when the printer requires attention, such as when a jam has occurred, then the printer ignores the flash drive.
  - If you insert the flash drive while the printer is printing other jobs, then **Printer Busy** appears. After the other jobs are processed, you may need to view the held jobs list to print documents from the flash drive.
- 3 Touch the document you want to print.

**Note:** Folders found on the flash drive appear as folders. File names are appended by the extension type (for example, .jpg).

4 Touch the arrows if you want to increase the number of printed copies.

5 Touch **Print**.

**Note:** Do not remove the flash drive from the USB port until the document has finished printing.

If you leave the flash drive in the printer after leaving the initial USB menu screen, then you can still print .pdf files from the flash drive as held jobs.

## Printing information pages



### Printing a directory list

A directory list shows the resources stored in flash memory or on the printer hard disk.

- 1 Make sure the printer is on and **Ready** appears.
- 2 On the home screen, touch .
- 3 Touch **Reports**.
- 4 Touch the down arrow until **Print Directory** appears.
- 5 Touch **Print Directory**.

### Printing the print quality test pages

Print the print quality test pages to isolate print quality problems.

- 1 Turn the printer off.
- 2 Hold down  and  while turning the printer on.
- 3 Release the buttons when the screen with the progress bar appears.  
The printer performs a power-on sequence, and then the Configuration menu appears.
- 4 Touch the down arrow until **Print Quality Pages** appears.
- 5 Touch **Print Quality Pages**.  
The print quality test pages print.
- 6 Touch **Back**.
- 7 Touch **Exit Configuration**.

## Canceling a print job

### Canceling a print job from the printer control panel

- 1 Touch **Cancel Jobs** on the touch screen, or press  on the keypad.
- 2 Touch the job you want to cancel.
- 3 Touch **Delete Selected Jobs**.

# Canceling a print job from the computer

To cancel a print job, do one of the following:

## For Windows users

In Windows Vista:

- 1 Click .
- 2 Click **Control Panel**.
- 3 Click **Hardware and Sound**.
- 4 Click **Printers**.
- 5 Double-click the printer icon.
- 6 Select the job to cancel.
- 7 From the keyboard, press **Delete**.

In Windows XP:

- 1 Click **Start**.
- 2 From **Printers and Faxes**, double-click the printer icon.
- 3 Select the job to cancel.
- 4 From the keyboard, press **Delete**.

From the Windows taskbar:

When you send a job to print, a small printer icon appears in the right corner of the taskbar.

- 1 Double-click the printer icon.  
A list of print jobs appears in the printer window.
- 2 Select a job to cancel.
- 3 From the keyboard, press **Delete**.

## For Macintosh users

In Mac OS X version 10.5:

- 1 From the Apple menu, choose **System Preferences**.
- 2 Click **Print & Fax**, and then double-click the printer icon.
- 3 From the printer window, select the job to cancel.
- 4 From the icon bar at the top of the window, click the **Delete** icon.

In Mac OS X version 10.4 and earlier:

- 1 From the Go menu, choose **Applications**.
- 2 Double-click **Utilities**, and then double-click **Print Center** or **Printer Setup Utility**.
- 3 Double-click the printer icon.



- 4 From the printer window, select the job to cancel.
- 5 From the icon bar at the top of the window, click the **Delete** icon.

# Clearing jams

Jam error messages appear on the control panel display and include the area of the printer where the jam occurred. When there is more than one jam, the number of jammed pages is displayed.

## Avoiding jams

The following hints can help you avoid jams.

### Paper tray recommendations

- Make sure the paper lies flat in the tray.
- Do not remove trays while the printer is printing.
- Do not load trays, the multipurpose feeder, or the envelope feeder while the printer is printing. Load them prior to printing, or wait for a prompt to load them.
- Do not load too much paper. Make sure the stack height does not exceed the indicated maximum height.
- Make sure the guides in the paper trays, multipurpose feeder, or envelope feeder are properly positioned and are not pressing too tightly against the paper or envelopes.
- Push all trays in firmly after loading paper.

### Paper recommendations

- Use only recommended paper or specialty media. For more information, see “Paper types and weights supported by the printer” on page 89.
- Do not load wrinkled, creased, damp, bent, or curled paper.
- Flex, fan, and straighten paper before loading it.
- Do not use paper that has been cut or trimmed by hand.
- Do not mix paper sizes, weights, or types in the same stack.
- Make sure all sizes and types are set correctly in the printer control panel menus.
- Store paper per the manufacturer's recommendations.

### Envelope recommendations

- To reduce wrinkling, use the Envelope Enhance menu in the Paper menu.
- Do not feed envelopes that:
  - Have excessive curl or twist
  - Have windows, holes, perforations, cutouts, or embossing
  - Have metal clasps, string ties, or folding bars
  - Have an interlocking design
  - Have postage stamps attached
  - Have any exposed adhesive when the flap is in the sealed or closed position
  - Have bent corners
  - Have rough, cockle, or laid finishes
  - Are stuck together or damaged in any way

# Understanding jam numbers and locations

When a jam occurs, a message indicating the jam location appears. Open doors and covers and remove trays to access jam locations. To resolve any paper jam message, you must clear all jammed paper from the paper path.

The following table lists the jams that can occur and the location of each jam:

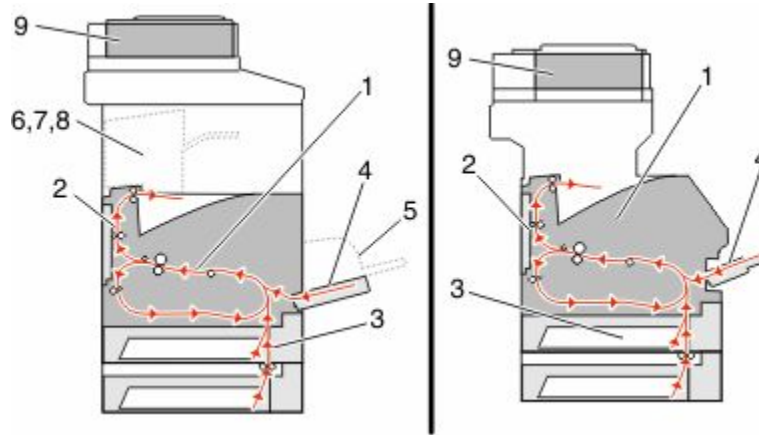

	Jam numbers	Area
<b>1</b>	200–202	Printer
<b>2</b>	230–239	Duplex unit
<b>3</b>	240–249	Paper tray
<b>4</b>	250	Multipurpose feeder
<b>5</b>	260	Envelope feeder
<b>6</b>	270–279	Optional output bin
<b>7</b>	280–282	Finisher
<b>8</b>	283	Stapler
<b>9</b>	290–294	ADF cover

## 200 and 201 paper jams

- 1** Touch **Status/Supplies** to identify the location of the jam.
- 2** Lower the multipurpose feeder door.

3 Push the release latch, and then open the front cover.

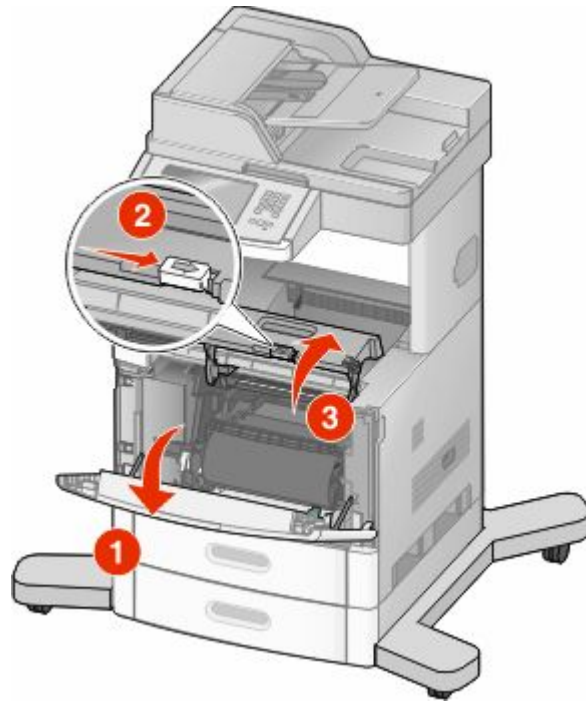

4 Lift and pull the print cartridge out of the printer.

**Warning—Potential Damage:** Do not touch the photoconductor drum on the underside of the cartridge. Use the cartridge handle whenever you are holding the cartridge.

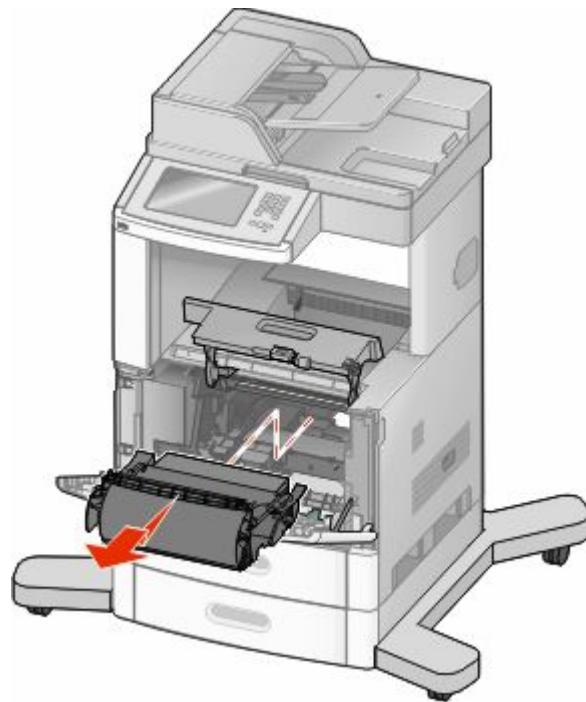

5 Place the print cartridge aside.

**Warning—Potential Damage:** Do not leave the cartridge exposed to light for extended periods.

**Warning—Potential Damage:** The jammed paper may be covered with unfused toner which can stain garments and skin.

6 Remove the jammed paper.



**CAUTION—HOT SURFACE:** The inside of the printer might be hot. To reduce the risk of injury from a hot component, allow the surface to cool before touching.

**Note:** If the paper is not easy to remove, then open the rear door and remove the paper from there.

7 Align and reinstall the print cartridge.

8 Close the front cover.

9 Close the multipurpose feeder door.

10 Touch **Continue**.

## 202 paper jam

Touch **Status/Supplies** to identify the location of the jam. If the paper is exiting the printer, then pull the paper out, and then touch **Continue**.

If the paper is not exiting the printer:

1 Pull down the top rear door.

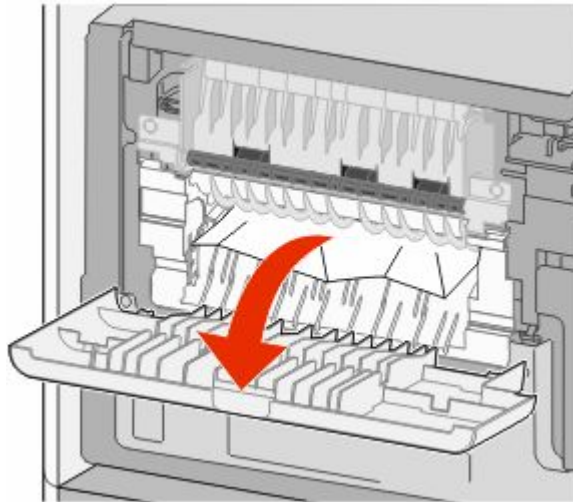

2 Remove the jammed paper.

3 Close the top rear door.

4 Touch **Continue**.

## 230–239 paper jams

- 1 Touch **Status/Supplies** to identify the location of the jam.
- 2 Pull the standard tray out.
- 3 Pull down the bottom rear door.

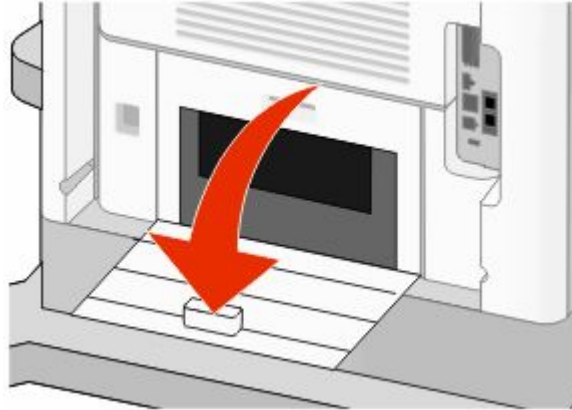

- 4 Push the tab down.

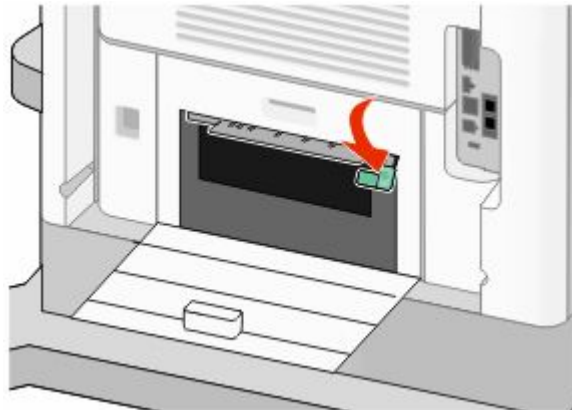

- 5 Remove the jammed paper.
- 6 Close the bottom rear door.
- 7 Insert the standard tray.
- 8 Touch **Continue**.

## 240–249 paper jams

- 1 Touch **Status/Supplies** to identify the location of the jam.
- 2 Pull the standard tray out.

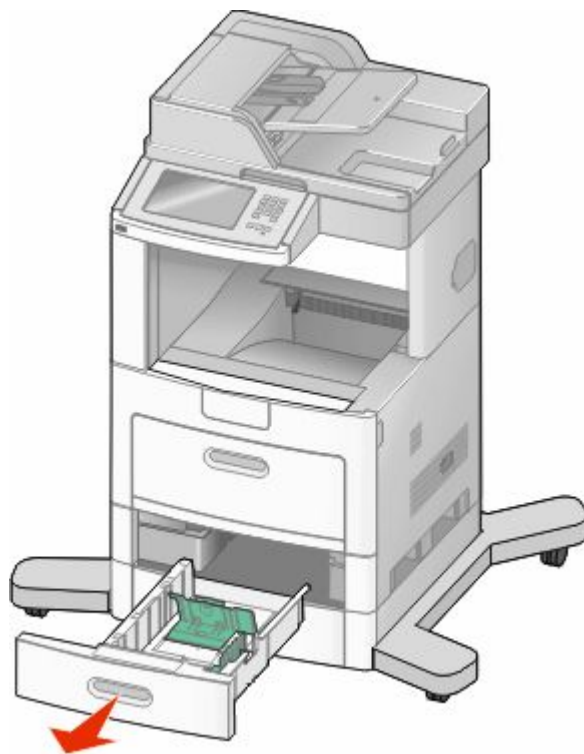

- 3 Remove any jammed paper, and then close the tray.
- 4 Touch **Continue**.
- 5 If the jam message persists, then pull out any optional trays.
- 6 Remove the jammed paper, and then insert the trays.
- 7 Touch **Continue**.

## 250 paper jam

- 1 Touch **Status/Supplies** to identify the location of the jam.
- 2 Remove the paper from the multipurpose feeder.

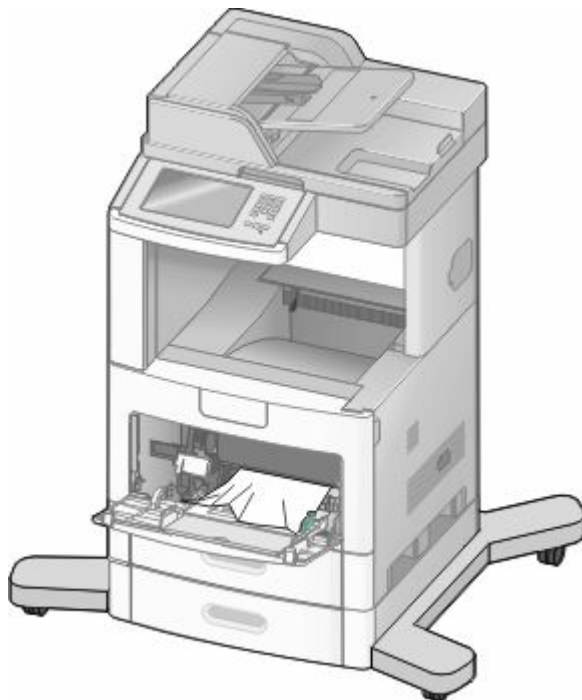

- 3 Flex the sheets of paper back and forth to loosen them, and then fan them. Do not fold or crease the paper. Straighten the edges on a level surface.
- 4 Load the paper into the multipurpose feeder.
- 5 Slide the paper guide toward the inside of the tray until it lightly rests against the edge of the paper.

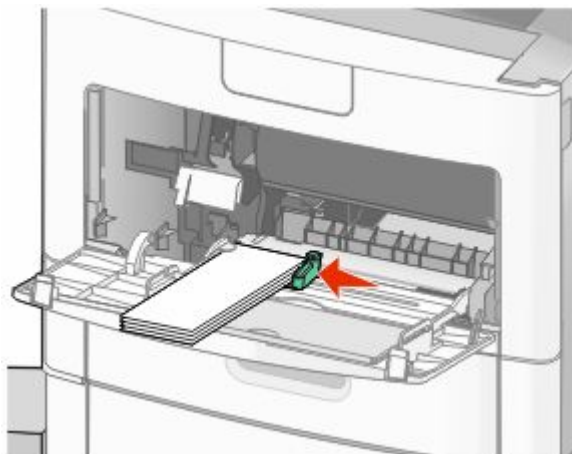

- 6 Touch **Continue**.



## 260 paper jam

Touch **Status/Supplies** to identify the location of the jam. The envelope feeder feeds envelopes from the bottom of the stack; the bottom envelope will be the one that is jammed.

- 1 Lift the envelope weight.
- 2 Remove all envelopes.
- 3 If the jammed envelope has entered the printer and cannot be pulled out, then lift the envelope feeder up and then out of the printer, and then set it aside.
- 4 Remove the envelope from the printer.  
**Note:** If you cannot remove the envelope, then the print cartridge will have to be removed. For more information, see "200 and 201 paper jams" on page 139.
- 5 Reinstall the envelope feeder. Make sure it *snaps* into place.
- 6 Flex and stack the envelopes.
- 7 Load the envelopes in the envelope feeder.
- 8 Adjust the paper guide.
- 9 Lower the envelope weight.
- 10 Touch **Continue**.

## 270–279 paper jams

To clear a jam in the high-capacity output stacker or the 4-bin mailbox:

- 1 Touch **Status/Supplies** to identify the location of the jam.
- 2 If the paper is exiting into a bin, then pull the paper straight out, and then touch **Continue**.  
If not, then continue with step 3.
- 3 Pull down the output bin door or doors.
- 4 Remove the jammed paper.
- 5 Close the output bin door or doors.
- 6 Touch **Continue**.

## 280–282 paper jams

- 1 Touch **Status/Supplies** to identify the location of the jam.
- 2 Pull down the StapleSmart finisher door.
- 3 Remove the jammed paper.
- 4 Close the StapleSmart finisher door.
- 5 Touch **Continue**.

## 283 staple jams

- 1 Touch **Status/Supplies** to identify the location of the jam.
- 2 Press the latch to open the stapler door.

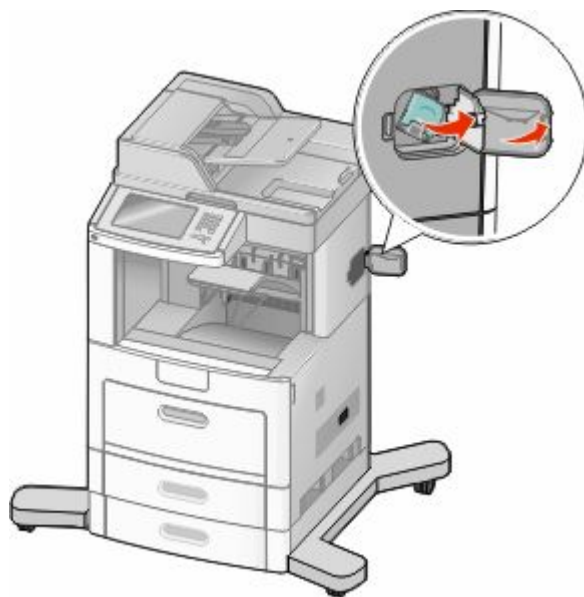

- 3 Pull the latch of the staple cartridge holder down, and then pull the holder out of the printer.

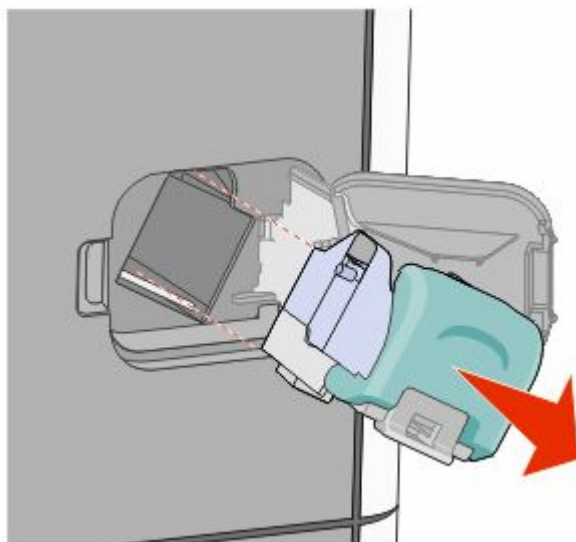

4 Use the metal tab to lift the staple guard, and then remove any loose staples.

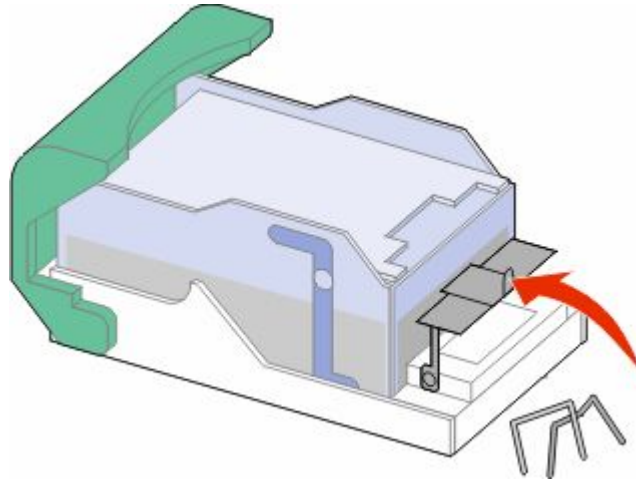

5 Close the staple guard.

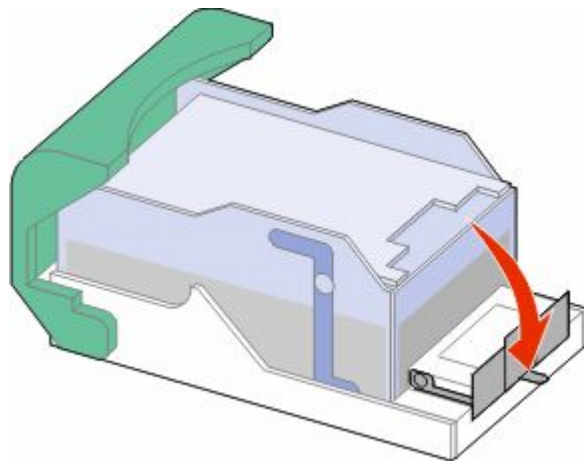

6 Press down on the staple guard until it *snaps* into place.

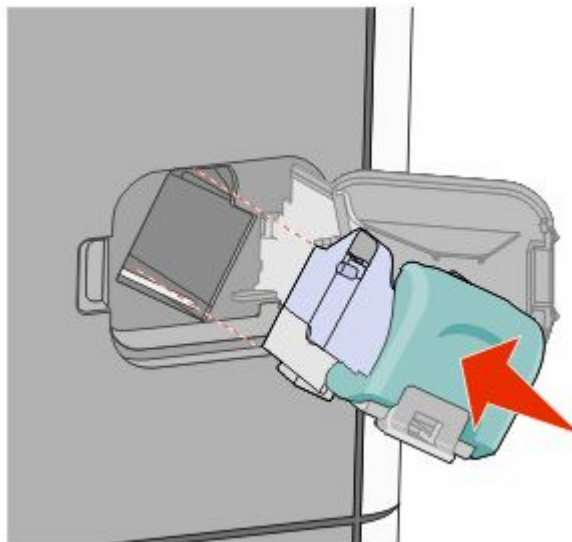

- 7 Push the cartridge holder firmly back into the stapler unit until the cartridge holder *clicks* into place.
- 8 Close the stapler door.

## 290–294 paper jams

- 1 Remove all original documents from the ADF.
- 2 Open the ADF cover, and then remove any jammed paper.

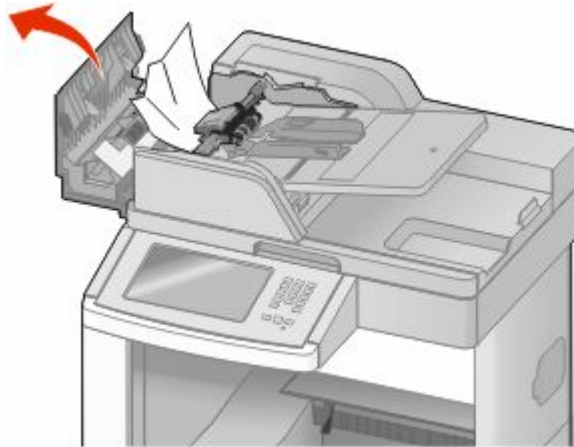

- 3 Close the ADF cover.
- 4 Open the scanner cover, and then remove any jammed pages.

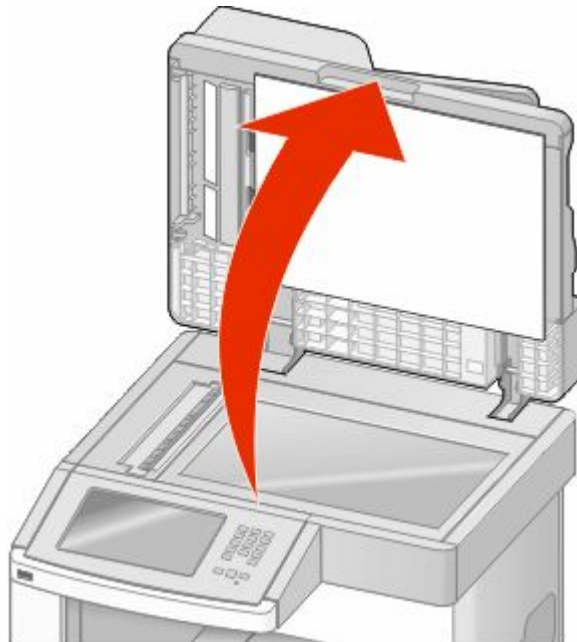

5 Open the bottom ADF door, and then remove any jammed pages.

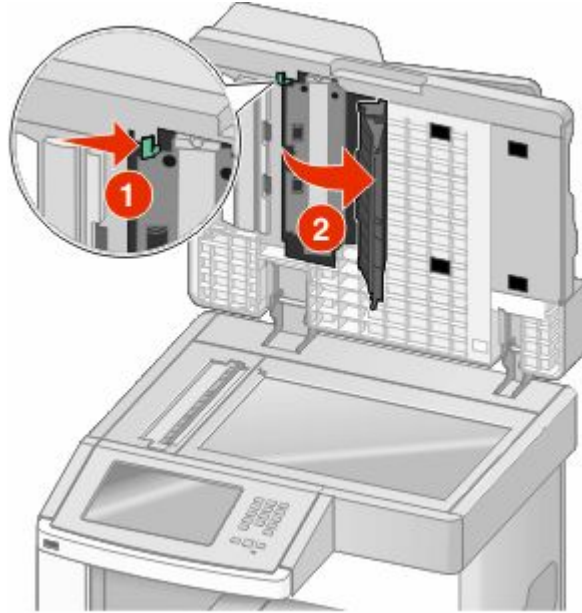

6 Close the bottom ADF door and scanner cover.

7 Touch **Restart Job**.

# Understanding printer menus

## Menu list

A number of menus are available to make it easy for you to change printer settings. To access the menus, touch  on the home screen.

### Paper Menu

- Default Source
- Paper Size/Type
- Configure MP
- Envelope Enhance
- Substitute Size
- Paper Texture
- Paper Weight
- Paper Loading
- Custom Types
- Custom Names
- Custom Scan Sizes
- Custom Bin Names
- Universal Setup
- Bin Setup

### Reports

- Menu Settings Page
- Device Statistics
- Network Setup Page
- Network <x> Setup Page
- Wireless Setup Page<sup>1</sup>
- Shortcut List
- Fax Job Log
- Fax Call Log
- Copy Shortcuts
- E-mail Shortcuts
- Fax Shortcuts
- FTP Shortcuts
- Profiles List
- NetWare Setup Page
- Print Fonts
- Print Directory
- Asset Report

### Network/Ports

- Active NIC
- Standard Network<sup>2</sup>
- SMTP Setup
- Standard USB
- Parallel <x>
- Serial <x>

<sup>1</sup> Only appears if a wireless card is installed.

<sup>2</sup> Depending on the printer setup, this menu item appears as Standard Network or Network <x>.

### Security

- Edit Security Setups
- Miscellaneous Security Settings
- Confidential Print
- Disc Wiping
- Security Audit Log
- Set Date and Time

### Settings

- General Settings
- Copy Settings
- Fax Settings
- E-mail Settings
- FTP Settings
- Flash Drive Menu
- Print Settings

### Help

- Print all guides
- Copy guide
- E-mail guide
- Fax guide
- FTP guide
- Information guide
- Print Defects guide

# Paper menu

## Default Source menu

Menu item	Description
<b>Default Source</b> Tray <x> MP Feeder Envelope Feeder Manual Paper Manual Env	Sets a default paper source for all print jobs <b>Notes:</b> <ul style="list-style-type: none"><li>• Tray 1 (standard tray) is the factory default setting.</li><li>• Only an installed paper source will appear as a menu setting.</li><li>• A paper source selected by a print job will override the Default Source setting for the duration of the print job.</li><li>• If the same size and type of paper are in two trays and the Paper Size and Paper Type settings match, then the trays are automatically linked. When one tray is empty, the job prints using the linked tray.</li><li>• From the Paper menu, Configure MP must be set to Cassette in order for MP Feeder to appear as a menu setting.</li></ul>

## Paper Size/Type menu

Menu item	Description
<b>Tray &lt;x&gt; Size</b> A4 A5 A6 JIS B5 Letter Legal Executive <sup>1</sup> Oficio <sup>1</sup> Folio Statement <sup>1</sup> Universal	Specifies the paper size loaded in each tray <b>Notes:</b> <ul style="list-style-type: none"><li>• A4 is the international factory default setting. Letter is the US factory default setting.</li><li>• For trays with automatic size sensing, only the size detected by the hardware appears.</li><li>• Use this menu item to configure automatic tray linking. If the same size and type of paper are in two trays and the Paper Size and Paper Type settings match, then the trays are automatically linked. When one tray is empty, the job prints using the linked tray.</li><li>• Automatic size sensing is not supported for Oficio, Folio, or Statement paper sizes.</li><li>• The 2000-sheet tray supports A4, Letter, and Legal paper sizes.</li></ul>

<sup>1</sup> Appears only if Tray Size Sensing is turned off.

**Note:** Only installed trays, drawers, and feeders are listed in this menu.

Menu item	Description
<p><b>Tray &lt;x&gt; Type</b></p> <ul style="list-style-type: none"> <li>Plain Paper</li> <li>Card Stock</li> <li>Transparency</li> <li>Recycled</li> <li>Bond</li> <li>Letterhead</li> <li>Preprinted</li> <li>Colored Paper</li> <li>Light Paper</li> <li>Heavy Paper</li> <li>Rough/Cotton Paper</li> <li>Custom Type &lt;x&gt;</li> </ul>	<p>Specifies the type of paper loaded in each tray</p> <p><b>Notes:</b></p> <ul style="list-style-type: none"> <li>• Plain Paper is the factory default setting for Tray 1. Custom Type &lt;x&gt; is the factory default setting for all other trays.</li> <li>• If available, a user-defined name will appear instead of Custom Type &lt;x&gt;.</li> <li>• Use this menu item to configure automatic tray linking. If the same size and type of paper are in two trays and the Paper Size and Paper Type settings match, then the trays are automatically linked. When one tray is empty, the job prints using the linked tray.</li> </ul>
<p><b>MP Feeder Size</b></p> <ul style="list-style-type: none"> <li>A4</li> <li>A5</li> <li>A6</li> <li>JIS B5</li> <li>Letter</li> <li>Legal</li> <li>Executive</li> <li>Oficio</li> <li>Folio</li> <li>Statement</li> <li>Universal</li> <li>7 3/4 Envelope</li> <li>9 Envelope</li> <li>10 Envelope</li> <li>DL Envelope</li> <li>Other Envelope</li> </ul>	<p>Specifies the paper size loaded in the multipurpose feeder</p> <p><b>Notes:</b></p> <ul style="list-style-type: none"> <li>• From the Paper menu, Configure MP must be set to Cassette in order for MP Feeder Size to appear as a menu item.</li> <li>• A4 is the international factory default setting. Letter is the US factory default setting.</li> <li>• The multipurpose feeder does not automatically sense paper size. The paper size value must be set.</li> </ul>
<p><sup>1</sup> Appears only if Tray Size Sensing is turned off.</p> <p><b>Note:</b> Only installed trays, drawers, and feeders are listed in this menu.</p>	



Menu item	Description
<p><b>MP Feeder Type</b></p> <ul style="list-style-type: none"> <li>Plain Paper</li> <li>Card Stock</li> <li>Transparency</li> <li>Recycled</li> <li>Bond</li> <li>Envelope</li> <li>Rough Envelope</li> <li>Letterhead</li> <li>Preprinted</li> <li>Colored Paper</li> <li>Light Paper</li> <li>Heavy Paper</li> <li>Rough/Cotton Paper</li> <li>Custom Type &lt;x&gt;</li> </ul>	<p>Specifies the type of paper loaded in the multipurpose feeder</p> <p><b>Notes:</b></p> <ul style="list-style-type: none"> <li>• From the Paper menu, Configure MP must be set to Cassette in order for MP Feeder Type to appear as a menu item.</li> <li>• Plain paper is the factory default setting.</li> </ul>
<p><b>Envelope Feeder Size</b></p> <ul style="list-style-type: none"> <li>7 3/4 Envelope</li> <li>9 Envelope</li> <li>10 Envelope</li> <li>DL Envelope</li> <li>Other Envelope</li> </ul>	<p>Specifies the envelope size loaded in the envelope feeder</p> <p><b>Note:</b> DL Envelope is the international factory default setting. 10 Envelope is the US factory default setting.</p>
<p><b>Envelope Feeder Type</b></p> <ul style="list-style-type: none"> <li>Envelope</li> <li>Rough Envelope</li> <li>Custom Type &lt;x&gt;</li> </ul>	<p>Specifies the type of envelope loaded in the envelope feeder</p> <p><b>Notes:</b></p> <ul style="list-style-type: none"> <li>• Envelope is the factory default setting.</li> <li>• The Custom Type setting can be used to store up to six types of envelopes.</li> </ul>
<p><b>Manual Paper Size</b></p> <ul style="list-style-type: none"> <li>A4</li> <li>A5</li> <li>A6</li> <li>JIS B5</li> <li>Letter</li> <li>Legal</li> <li>Executive</li> <li>Oficio</li> <li>Folio</li> <li>Statement</li> <li>Universal</li> </ul>	<p>Specifies the size of the paper being manually loaded</p> <p><b>Note:</b> A4 is the international factory default setting. Letter is the US factory default setting.</p>
<p><sup>1</sup> Appears only if Tray Size Sensing is turned off.</p> <p><b>Note:</b> Only installed trays, drawers, and feeders are listed in this menu.</p>	

Menu item	Description
<b>Manual Paper Type</b> Plain Paper Card Stock Transparency Recycled Bond Letterhead Preprinted Colored Paper Light Paper Heavy Paper Rough/Cotton Paper Custom Type <x>	Specifies the type of paper being manually loaded <b>Note:</b> Plain Paper is the factory default setting.
<b>Manual Envelope Size</b> 7 3/4 Envelope 9 Envelope 10 Envelope DL Envelope Other Envelope	Specifies the size of the envelope being manually loaded <b>Note:</b> DL Envelope is the international factory default setting. 10 Envelope is the US factory default setting.
<b>Manual Envelope Type</b> Envelope Rough Envelope Custom Type <x>	Specifies the type of envelope being manually loaded <b>Note:</b> Envelope is the factory default setting.
<sup>1</sup> Appears only if Tray Size Sensing is turned off. <b>Note:</b> Only installed trays, drawers, and feeders are listed in this menu.	

## Configure MP menu

Menu item	Description
<b>Configure MP</b> Cassette Manual First	Determines when the printer selects paper from the multipurpose feeder <b>Notes:</b> <ul style="list-style-type: none"> <li>• Cassette is the factory default setting.</li> <li>• The Cassette setting configures the multipurpose feeder as an automatic paper source.</li> <li>• When Manual is selected, the multipurpose feeder can be used only for manual feed print jobs.</li> <li>• If paper is loaded in the multipurpose feeder and First is selected, then paper always feeds from the multipurpose feeder first.</li> </ul>

## Envelope Enhance

The envelope conditioner significantly reduces the wrinkling of some envelopes.

Menu item	Description
<b>Envelope Enhance</b> Off 1 (Least) 2 3 4 5 6 (Most)	Enables or disables the envelope conditioner  <b>Notes:</b> <ul style="list-style-type: none"> <li>• The factory default setting is 5.</li> <li>• If noise reduction is more important than wrinkle reduction, then decrease the setting.</li> </ul>

## Substitute Size menu

Menu item	Description
<b>Substitute Size</b> Off Statement/A5 Letter/A4 All Listed	Substitutes a specified paper size if the requested paper size is not available  <b>Notes:</b> <ul style="list-style-type: none"> <li>• All Listed is the factory default setting. All available substitutions are allowed.</li> <li>• The Off setting indicates no size substitutions are allowed.</li> <li>• Setting a substitution lets the job print without a Change Paper message appearing.</li> </ul>

## Paper Texture menu

Menu item	Description
<b>Plain Texture</b> Smooth Normal Rough	Specifies the relative texture of the paper loaded in a specific tray <b>Note:</b> Normal is the factory default setting.
<b>Card Stock Texture</b> Smooth Normal Rough	Specifies the relative texture of the card stock loaded in a specific tray <b>Notes:</b> <ul style="list-style-type: none"> <li>• Normal is the factory default setting.</li> <li>• Settings appear only if card stock is supported.</li> </ul>
<b>Transparency Texture</b> Smooth Normal Rough	Specifies the relative texture of the transparencies loaded in a specific tray <b>Note:</b> Normal is the factory default setting.

Menu item	Description
<b>Recycled Texture</b> Smooth Normal Rough	Specifies the relative texture of the recycled paper loaded in a specific tray <b>Note:</b> Normal is the factory default setting.
<b>Bond Texture</b> Smooth Normal Rough	Specifies the relative texture of the paper loaded in a specific tray <b>Note:</b> Rough is the factory default setting.
<b>Envelope Texture</b> Smooth Normal Rough	Specifies the relative texture of the envelopes loaded in a specific tray <b>Note:</b> Normal is the factory default setting.
<b>Rough Envelope Texture</b> Smooth Normal Rough	Specifies the relative texture of the rough envelopes loaded in a specific tray <b>Note:</b> Rough is the factory default setting.
<b>Letterhead Texture</b> Smooth Normal Rough	Specifies the relative texture of the paper loaded in a specific tray <b>Note:</b> Normal is the factory default setting.
<b>Preprinted Texture</b> Smooth Normal Rough	Specifies the relative texture of the paper loaded in a specific tray <b>Note:</b> Normal is the factory default setting.
<b>Colored Texture</b> Smooth Normal Rough	Specifies the relative texture of the paper loaded in a specific tray <b>Note:</b> Normal is the factory default setting.
<b>Light Texture</b> Smooth Normal Rough	Specifies the relative texture of the paper loaded in a specific tray <b>Note:</b> Normal is the factory default setting.
<b>Heavy Texture</b> Smooth Normal Rough	Specifies the relative texture of the paper loaded in a specific tray <b>Note:</b> Normal is the factory default setting.
<b>Rough Texture</b> Smooth Normal Rough	Specifies the relative texture of the paper loaded in a specific tray <b>Note:</b> Rough is the factory default setting.

Menu item	Description
<b>Custom &lt;x&gt; Texture</b> Smooth Normal Rough	Specifies the relative texture of the custom paper loaded in a specific tray <b>Note:</b> Normal is the factory default setting.

## Paper Weight menu

Menu item	Description
<b>Plain Weight</b> Light Normal Heavy	Specifies the relative weight of the paper loaded in a specific tray <b>Note:</b> Normal is the factory default setting.
<b>Card Stock Weight</b> Light Normal Heavy	Specifies the relative weight of the card stock loaded in a specific tray <b>Note:</b> Normal is the factory default setting.
<b>Transparency Weight</b> Light Normal Heavy	Specifies the relative weight of the paper loaded in a specific tray <b>Note:</b> Normal is the factory default setting.
<b>Recycled Weight</b> Light Normal Heavy	Specifies the relative weight of the recycled paper loaded in a specific tray <b>Note:</b> Normal is the factory default setting.
<b>Bond Weight</b> Light Normal Heavy	Specifies the relative weight of the paper loaded in a specific tray <b>Note:</b> Normal is the factory default setting.
<b>Envelope Weight</b> Light Normal Heavy	Specifies the relative weight of the envelopes loaded in a specific tray <b>Note:</b> Normal is the factory default setting.
<b>Rough Envelope Weight</b> Light Normal Heavy	Specifies the relative weight of the rough envelopes loaded in a specific tray <b>Note:</b> Normal is the factory default setting.
<b>Letterhead Weight</b> Light Normal Heavy	Specifies the relative weight of the paper loaded in a specific tray <b>Note:</b> Normal is the factory default setting.

Menu item	Description
<b>Preprinted Weight</b> Light Normal Heavy	Specifies the relative weight of the paper loaded in a specific tray <b>Note:</b> Normal is the factory default setting.
<b>Colored Weight</b> Light Normal Heavy	Specifies the relative weight of the paper loaded in a specific tray <b>Note:</b> Normal is the factory default setting.
<b>Light Weight</b> Light	Specifies the relative weight of the paper loaded in a specific tray
<b>Heavy Weight</b> Heavy	Specifies the relative weight of the paper loaded in a specific tray
<b>Rough Weight</b> Light Normal Heavy	Specifies the relative weight of the paper loaded in a specific tray <b>Note:</b> Normal is the factory default setting.
<b>Custom &lt;x&gt;</b> Light Normal Heavy	Specifies the relative weight of the custom paper type loaded in a specific tray <b>Notes:</b> <ul style="list-style-type: none"> <li>• Normal is the factory default setting.</li> <li>• Settings appear only if the custom type is supported.</li> </ul>

## Paper Loading menu

Menu item	Description
<b>Card Stock Loading</b> Duplex Off	Determines whether 2-sided printing occurs for all jobs that specify Card Stock as the paper type <b>Note:</b> Off is the factory default setting.
<b>Recycled Loading</b> Duplex Off	Determines whether 2-sided printing occurs for all jobs that specify Recycled as the paper type <b>Note:</b> Off is the factory default setting.
<b>Bond Loading</b> Duplex Off	Determines whether 2-sided printing occurs for all jobs that specify Bond as the paper type <b>Note:</b> Off is the factory default setting.
<b>Letterhead Loading</b> Duplex Off	Determines whether 2-sided printing occurs for all jobs that specify Letterhead as the paper type <b>Note:</b> Off is the factory default setting.
<b>Notes:</b> <ul style="list-style-type: none"> <li>• Duplex sets the printer default to 2-sided printing for every print job unless 1-sided printing is selected from Print Properties in Windows or the Print dialog in Macintosh.</li> <li>• If Duplex is selected, all print jobs are sent through the duplex unit, including 1-sided jobs.</li> </ul>	

Menu item	Description
<b>Preprinted Loading</b> Duplex Off	Determines whether 2-sided printing occurs for all jobs that specify Preprinted as the paper type <b>Note:</b> Off is the factory default setting.
<b>Colored Loading</b> Duplex Off	Determines whether 2-sided printing occurs for all jobs that specify Colored as the paper type <b>Note:</b> Off is the factory default setting.
<b>Light Loading</b> Duplex Off	Determines whether 2-sided printing occurs for all jobs that specify Light as the paper type <b>Note:</b> Off is the factory default setting.
<b>Heavy Loading</b> Duplex Off	Determines whether 2-sided printing occurs for all jobs that specify Heavy as the paper type <b>Note:</b> Off is the factory default setting.
<b>Rough Loading</b> Duplex Off	Determines whether 2-sided printing occurs for all jobs that specify Rough as the paper type <b>Note:</b> Off is the factory default setting.
<b>Custom &lt;x&gt; Loading</b> Duplex Off	Determines whether 2-sided printing occurs for all jobs that specify Custom <x> as the paper type <b>Notes:</b> <ul style="list-style-type: none"> <li>• Off is the factory default setting.</li> <li>• Custom &lt;x&gt; Loading is available only if the custom type is supported.</li> </ul>
<b>Notes:</b> <ul style="list-style-type: none"> <li>• Duplex sets the printer default to 2-sided printing for every print job unless 1-sided printing is selected from Print Properties in Windows or the Print dialog in Macintosh.</li> <li>• If Duplex is selected, all print jobs are sent through the duplex unit, including 1-sided jobs.</li> </ul>	

## Custom Types menu

Menu item	Description
<b>Custom Type &lt;x&gt;</b> Paper Card Stock Transparency Envelope	Associates a paper or specialty media type with a factory default <b>Custom Type &lt;x&gt;</b> name or a user-defined Custom Name created from the Embedded Web Server or MarkVision Professional <b>Notes:</b> <ul style="list-style-type: none"> <li>• Paper is the factory default setting.</li> <li>• The custom media type must be supported by the selected tray or multipurpose feeder in order to print from that source.</li> </ul>
<b>Recycled</b> Paper Card Stock Transparency Envelope	Specifies a paper type when the Recycled setting is selected in other menus <b>Notes:</b> <ul style="list-style-type: none"> <li>• Paper is the factory default setting.</li> <li>• The custom media type must be supported by the selected tray or multipurpose feeder in order to print from that source.</li> </ul>

## Custom Names menu

Menu item	Definition
<b>Custom Name &lt;x&gt;</b> <none>	Specify a custom name for a paper type. This name replaces a <b>Custom Type &lt;x&gt;</b> name in the printer menus.

## Custom Scan Sizes menu

Menu item	Description
<b>Custom Scan Size &lt;x&gt;</b> Scan Size Name Width 3–14.17 inches (76–360 mm) Height 3–14.17 inches (76–360 mm) Orientation Landscape Portrait 2 scans per side Off On ADF Pick Roller Force User Default 30% 40% 50% 60% 70% 80%	Specifies a custom scan size name and options. This name replaces a <b>Custom Scan Size &lt;x&gt;</b> name in the printer menus.  <b>Notes:</b> <ul style="list-style-type: none"> <li>• 8.5 Inches is the US factory default setting for Width. 216 millimeters is the international factory default setting for Width.</li> <li>• 14 Inches is the US factory default setting for Height. 356 millimeters is the international factory default setting for Height.</li> <li>• Landscape is the factory default setting for Orientation.</li> <li>• Off is the factory default setting for 2 scans per side.</li> <li>• User Default is the factory default setting for ADF Pick Roller Force.</li> </ul>

## Custom Bin Names menu

Menu Item	Description
<b>Standard Bin</b>	Specifies a custom name for the Standard Bin
<b>Bin 1</b>	Specifies a custom name for Bin 1



## Universal Setup menu

These menu items are used to specify the height, width, and feed direction of the Universal Paper Size. The Universal Paper Size is a user-defined paper size setting. It is listed with the other paper size settings and includes similar options, such as support for duplex printing and printing multiple pages on one sheet.

Menu item	Description
<b>Units of Measure</b> Inches Millimeters	Identifies the units of measure  <b>Notes:</b> <ul style="list-style-type: none"> <li>• Inches is the US factory default setting.</li> <li>• Millimeters is the international factory default setting.</li> </ul>
<b>Portrait Width</b> 3–14 inches 76–360 mm	Sets the portrait width  <b>Notes:</b> <ul style="list-style-type: none"> <li>• If the width exceeds the maximum, the printer uses the maximum width allowed.</li> <li>• 8.5 inches is the US factory default setting. Inches can be increased in 0.01-inch increments.</li> <li>• 216 mm is the international factory default setting. Millimeters can be increased in 1-mm increments.</li> </ul>
<b>Portrait Height</b> 3–14 inches 76–360 mm	Sets the portrait height  <b>Notes:</b> <ul style="list-style-type: none"> <li>• If the height exceeds the maximum, the printer uses the maximum height allowed.</li> <li>• 14 inches is the US factory default setting. Inches can be increased in 0.01-inch increments.</li> <li>• 356 mm is the international factory default setting. Millimeters can be increased in 1-mm increments.</li> </ul>
<b>Feed Direction</b> Short Edge Long Edge	Specifies the feed direction if the paper can be loaded in either direction  <b>Notes:</b> <ul style="list-style-type: none"> <li>• Short Edge is the factory default setting.</li> <li>• Long Edge appears only if the longest edge is shorter than the maximum width supported in the tray.</li> </ul>

## Bin Setup menu

Menu Item	Description
<b>Output Bin</b> Standard Bin Bin <x>	Identifies installed output bins  <b>Note:</b> Standard Bin is the factory default setting.

Menu Item	Description
<b>Configure Bins</b> Mailbox Link Mail Overflow Link Optional Type Assignment	Specifies configuration options for output bins <b>Notes:</b> <ul style="list-style-type: none"> <li>• Mailbox is the factory default setting.</li> <li>• The Mailbox setting treats each bin as a separate mailbox.</li> <li>• The Link setting links together all available output bins.</li> <li>• The Mail Overflow setting treats each bin as a separate mailbox until a bin becomes full, and then the printer automatically diverts sheets to an overflow bin.</li> <li>• The Link Optional setting links together all available output bins except the standard bin and only appears when at least two optional bins are installed.</li> <li>• The Type Assignment setting assigns each paper type to an output bin.</li> </ul>
<b>Assign Type/Bin</b> Plain Paper Bin Card Stock Bin Transparency Bin Recycled Bin Bond Bin Envelope Bin Rough Envelope Bin Letterhead Bin Preprinted Bin Colored Bin Light Bin Heavy Bin Rough Bin Custom <x> Bin	Selects an output bin for each supported paper type Available selections for each type are: Disabled Standard Bin Bin <x> <b>Note:</b> Standard Bin is the factory default setting.

## Reports menu

**Note:** When you select a menu item from the Reports menu, the indicated report prints.

Menu item	Description
<b>Menu Settings Page</b>	Prints a report containing information about paper loaded into trays, installed memory, the total page count, alarms, timeouts, the control panel language, the TCP/IP address, the status of supplies, the status of the network connection, and other information
<b>Device Statistics</b>	Prints a report containing printer statistics such as supply information and details about printed pages

Menu item	Description
<b>Network Setup Page</b>	Prints a report containing information about the network printer settings, such as the TCP/IP address information <b>Note:</b> This menu item appears only for network printers or printers connected to print servers.
<b>Network &lt;x&gt; Setup Page</b>	Prints a report containing information about the network printer settings, such as the TCP/IP address information <b>Notes:</b> <ul style="list-style-type: none"> <li>• This menu item is available when more than one network option is installed.</li> <li>• This menu item appears only for network printers or printers connected to print servers.</li> </ul>
<b>Wireless Setup Page</b>	Prints a report containing information about the wireless network printer settings, such as the TCP/IP address information <b>Notes:</b> <ul style="list-style-type: none"> <li>• This menu item is available when a wireless card is installed.</li> <li>• This menu item appears only for network printers or printers connected to print servers.</li> </ul>
<b>Shortcut List</b>	Prints a report containing information about configured shortcuts
<b>Fax Job Log</b>	Prints a report containing information about the last 200 completed faxes
<b>Fax Call Log</b>	Prints a report containing information about the last 100 attempted, received, and blocked calls
<b>Copy Shortcuts</b>	Prints a report containing information about copy shortcuts
<b>E-mail Shortcuts</b>	Prints a report containing information about e-mail shortcuts
<b>Fax Shortcuts</b>	Prints a report containing information about fax shortcuts
<b>FTP Shortcuts</b>	Prints a report containing information about FTP shortcuts
<b>Profiles List</b>	Prints a list of profiles stored in the printer
<b>NetWare Setup Page</b>	Prints a report containing NetWare-specific information about the network settings <b>Note:</b> This menu item appears only for printers with an internal print server installed.
<b>Print Fonts</b>	Prints a report of all the fonts available for the printer language currently set in the printer
<b>Print Directory</b>	Prints a list of all the resources stored on an optional flash memory card or printer hard disk <b>Notes:</b> <ul style="list-style-type: none"> <li>• Job Buffer Size must be set to 100%.</li> <li>• The optional flash memory or printer hard disk must be installed correctly and working properly.</li> </ul>
<b>Asset Report</b>	Prints a report containing asset information including the printer serial number and model name. The report contains text and UPC barcodes that can be scanned into an asset database.

# Network/Ports menu

## Active NIC menu

Menu item	Description
<b>Active NIC</b> Auto <list of available network cards>	<b>Notes:</b> <ul style="list-style-type: none"> <li>• Auto is the factory default setting.</li> <li>• This menu item appears only if an optional network card is installed.</li> </ul>

## Standard Network or Network <x> menus

**Note:** Only active ports appear in this menu; all inactive ports are omitted.

Menu item	Description
<b>PCL SmartSwitch</b> On Off	Sets the printer to automatically switch to PCL emulation when a print job requires it, regardless of the default printer language  <b>Notes:</b> <ul style="list-style-type: none"> <li>• On is the factory default setting.</li> <li>• When the Off setting is used, the printer does not examine incoming data.</li> <li>• When the Off setting is used, the printer uses PostScript emulation if PS SmartSwitch is set to On. It uses the default printer language specified in the Setup menu if PS SmartSwitch is set to Off.</li> </ul>
<b>PS SmartSwitch</b> On Off	Sets the printer to automatically switch to PS emulation when a print job requires it, regardless of the default printer language  <b>Notes:</b> <ul style="list-style-type: none"> <li>• On is the factory default setting.</li> <li>• When the Off setting is used, the printer does not examine incoming data.</li> <li>• When the Off setting is used, the printer uses PCL emulation if PCL SmartSwitch is set to On. It uses the default printer language specified in the Setup menu if PCL SmartSwitch is set to Off.</li> </ul>
<b>NPA Mode</b> Off Auto	Sets the printer to perform the special processing required for bidirectional communication following the conventions defined by the NPA protocol  <b>Notes:</b> <ul style="list-style-type: none"> <li>• Auto is the factory default setting.</li> <li>• Changing this setting from the printer control panel and then exiting the menus causes the printer to restart. The menu selection is updated.</li> </ul>

Menu item	Description
<b>Network Buffer</b> Auto 3K to <maximum size allowed>	Sets the size of the network input buffer <b>Notes:</b> <ul style="list-style-type: none"> <li>• Auto is the factory default setting.</li> <li>• The value can be changed in 1-K increments.</li> <li>• The maximum size allowed depends on the amount of memory in the printer, the size of the other link buffers, and whether Resource Save is set to On or Off.</li> <li>• To increase the maximum size range for the Network Buffer, disable or reduce the size of the parallel, serial, and USB buffers.</li> <li>• Changing this setting from the printer control panel and then exiting the menus causes the printer to restart. The menu selection is updated.</li> </ul>
<b>Job Buffering</b> Off On Auto	Temporarily stores jobs on the printer hard disk before printing. This menu only appears if a formatted disk is installed. <b>Notes:</b> <ul style="list-style-type: none"> <li>• Off is the factory default setting.</li> <li>• The On value buffers jobs on the printer hard disk. This menu selection appears only when a formatted disk is installed and is not defective.</li> <li>• The Auto setting buffers print jobs only if the printer is busy processing data from another input port.</li> <li>• Changing this setting from the printer control panel and then exiting the menus causes the printer to restart. The menu selection is updated.</li> </ul>
<b>Mac Binary PS</b> On Off Auto	Sets the printer to process Macintosh binary PostScript print jobs <b>Notes:</b> <ul style="list-style-type: none"> <li>• Auto is the factory default setting.</li> <li>• The Off setting filters print jobs using the standard protocol.</li> <li>• The On setting processes raw binary PostScript print jobs.</li> </ul>
<b>Std Network Setup</b> Reports or Network Reports Network Card TCP/IP IPv6 AppleTalk NetWare LexLink <b>Net &lt;x&gt; Setup</b> Reports or Network Reports Network Card TCP/IP IPv6 Wireless AppleTalk NetWare LexLink	For descriptions and settings of the network setup menus, see the following: <ul style="list-style-type: none"> <li>• “Network Reports menu” on page 167</li> <li>• “Network Card menu” on page 167</li> <li>• “TCP/IP menu” on page 167</li> <li>• “IPv6 menu” on page 169</li> <li>• “Wireless menu” on page 169</li> <li>• “AppleTalk menu” on page 170</li> <li>• “NetWare menu” on page 170</li> <li>• “LexLink menu” on page 171</li> </ul> <b>Note:</b> The Wireless menu appears only when the printer is connected to a wireless network.

## SMTP Setup menu

Use the following menu to configure the SMTP server.

Menu item	Description
<b>Primary SMTP Gateway</b> <b>Primary SMTP Gateway Port</b> <b>Secondary SMTP Gateway</b> <b>Secondary SMTP Gateway Port</b>	Specifies SMTP server port information <b>Note:</b> 25 is the default SMTP gateway port.
<b>SMTP Timeout</b> 5–30	Specifies the amount of time in seconds before the server stops trying to send the e-mail <b>Note:</b> 30 seconds is the factory default setting.
<b>Reply Address</b> <b>Use SSL</b> Disabled Negotiate Required	Specifies server information. This is a required item. <b>Notes:</b> <ul style="list-style-type: none"> <li>• The message box has a limitation of 512 characters.</li> <li>• Disabled is the factory default setting for Use SSL.</li> </ul>
<b>SMTP Server Authentication</b> No authentication required Login / Plain CRAM-MD5 Digest-MD5 NTLM Kerberos 5	Specifies the type of user authentication required for scan to e-mail privileges <b>Note:</b> “No authentication required” is the factory default setting.
<b>Device-Initiated E-mail</b> None Use Device SMTP Credentials <b>User-Initiated E-mail</b> None Use Device SMTP Credentials Use Session User ID and Password Use Session E-mail address and Password Prompt User <b>Device Userid</b> <b>Device password</b> <b>Kerberos 5 Realm</b> <b>NTLM Domain</b>	Specifies server information <b>Notes:</b> <ul style="list-style-type: none"> <li>• The message boxes have a limitation of 512 characters.</li> <li>• None is the factory default setting for Device-Initiated E-mail and User-Initiated E-mail.</li> </ul>

## Network Reports menu

This menu is available from the Network/Ports menu:

**Network/Ports → Standard Network or Network <x> → Std Network Setup or Net <x> Setup → Reports or Network Reports**

Menu item	Description
<b>Print Setup Page</b> <b>Print NetWare Setup Page</b>	Prints a report containing information about the current network setup <b>Notes:</b> <ul style="list-style-type: none"> <li>• The Setup Page contains information about the network printer settings, such as the TCP/IP address.</li> <li>• The NetWare Setup Page menu item appears only on models that support NetWare and shows information about NetWare settings.</li> </ul>

## Network Card menu

This menu is available from the Network/Ports menu:

**Network/Ports → Standard Network or Network <x> → Std Network Setup or Net <x> Setup → Network Card**

Menu item	Description
<b>View Card Status</b> Connected Disconnected	Lets you view the connection status of the Network Card
<b>View Card Speed</b>	Lets you view the speed of a currently active network card
<b>Network Address</b> UAA LAA	Lets you view the network addresses
<b>Job Timeout</b> 0-225 seconds	Sets the amount of time in seconds that a network print job can take before it is canceled <b>Notes:</b> <ul style="list-style-type: none"> <li>• 90 seconds is the factory default setting.</li> <li>• A setting value of 0 disables the timeout.</li> <li>• If a value of 1–9 is selected, then the setting is saved as 10.</li> </ul>
<b>Banner Page</b> Off On	Allows the printer to print a banner page <b>Note:</b> Off is the factory default setting.

## TCP/IP menu

Use the following menu items to view or set the TCP/IP information.

**Note:** This menu is available only for network models or printers attached to print servers.

This menu is available from the Network/Ports menu:

**Network/Ports → Standard Network or Network <x> → Std Network Setup or Net <x> Setup → TCP/IP**

Menu item	Description
<b>Activate</b> On Off	Activates TCP/IP <b>Note:</b> On is the factory default setting.
<b>View Hostname</b>	Lets you view the current TCP/IP hostname <b>Note:</b> This can be changed only from the Embedded Web Server.
<b>IP Address</b>	Lets you view or change the current TCP/IP Address <b>Note:</b> Manually setting the IP address sets the Enable DHCP and Enable Auto IP settings to Off. It also sets Enable BOOTP and Enable RARP to Off on systems that support BOOTP and RARP.
<b>Netmask</b>	Lets you view or change the current TCP/IP Netmask
<b>Gateway</b>	Lets you view or change the current TCP/IP Gateway
<b>Enable DHCP</b> On Off	Specifies the DHCP address and parameter assignment setting
<b>Enable RARP</b> On Off	Specifies the RARP address assignment setting <b>Note:</b> On is the factory default setting.
<b>Enable BOOTP</b> On Off	Specifies the BOOTP address assignment setting <b>Note:</b> On is the factory default setting.
<b>AutoIP</b> Yes No	Specifies the Zero Configuration Networking setting <b>Note:</b> Yes is the factory default setting.
<b>Enable FTP/TFTP</b> Yes No	Enables the built-in FTP server, which allows you to send files to the printer using the File Transfer Protocol. <b>Note:</b> Yes is the factory default setting.
<b>Enable HTTP Server</b> Yes No	Enables the built-in web server (Embedded Web Server). When enabled, the printer can be monitored and managed remotely using a web browser. <b>Note:</b> Yes is the factory default setting.
<b>WINS Server Address</b>	Lets you view or change the current WINS Server Address
<b>DNS Server Address</b>	Lets you view or change the current DNS Server Address



## IPv6 menu

Use the following menu items to view or set the Internet Protocol version 6 (IPv6) information.

**Note:** This menu is available only for network models or printers attached to print servers.

This menu is available from the Network/Ports menu:

**Network/Ports → Standard Network or Network <x> → Std Network Setup or Net <x> Setup → IPv6**

Menu item	Description
<b>Enable IPv6</b> On Off	Enables IPv6 in the printer <b>Note:</b> On is the factory default setting.
<b>Auto Configuration</b> On Off	Specifies whether the network adapter accepts the automatic IPv6 address configuration entries provided by a router <b>Note:</b> On is the factory default setting.
<b>View Hostname</b> <b>View Address</b> <b>View Router Address</b>	Lets you view the current setting <b>Note:</b> These settings can be changed only from the Embedded Web Server.
<b>Enable DHCPv6</b> On Off	Enables DHCPv6 in the printer <b>Note:</b> On is the factory default setting.

## Wireless menu

Use the following menu items to view or configure the wireless internal print server settings.

**Note:** This menu is available only for models connected to a wireless network.

This menu is available from the Network/Ports menu:

**Network/Ports → Network <x> → Net <x> Setup → Wireless**

Menu item	Description
<b>Network Mode</b> Infrastructure Ad hoc	Specifies the network mode <b>Notes:</b> <ul style="list-style-type: none"><li>• Infrastructure mode lets the printer access a network using an access point.</li><li>• Ad hoc is the factory default setting. Ad hoc mode configures the printer for wireless networking directly between it and a computer.</li></ul>
<b>Compatibility</b> 802.11n 802.11b/g 802.11b/g/n	Specifies the wireless standard for the wireless network
<b>Choose Network</b> <list of available networks>	Lets you select an available network for the printer to use
<b>View Signal Quality</b>	Lets you view the quality of the wireless connection

Menu item	Description
<b>View Security Mode</b>	Lets you view the encryption method for the wireless connection. "Disabled" indicates that the wireless network is not encrypted.

## AppleTalk menu

This menu is available from the Network/Ports menu:

**Network/Ports → Standard Network or Network <x> → Std Network Setup or Net <x> Setup → AppleTalk**

Menu item	Description
<b>Activate</b> On Off	Activates AppleTalk support <b>Note:</b> On is the factory default setting.
<b>View Name</b>	Shows the assigned AppleTalk name <b>Note:</b> The name can be changed only from the Embedded Web Server.
<b>View Address</b>	Shows the assigned AppleTalk address <b>Note:</b> The address can be changed only from the Embedded Web Server.
<b>Set Zone</b> <list of zones available on the network>	Provides a list of AppleTalk zones available on the network <b>Note:</b> The default setting is the default zone for the network. If no default zone exists, the zone marked with an * is the default setting.

## NetWare menu

This menu is available from the Network/Ports menu:

**Network/Ports → Standard Network or Network <x> → Std Network Setup or Net <x> Setup → NetWare**

Menu item	Description
<b>Activate</b> Yes No	Activates NetWare support <b>Note:</b> No is the factory default setting.
<b>View Login Name</b>	Lets you view the assigned NetWare login name <b>Note:</b> This can be changed only from the Embedded Web Server.
<b>Print Mode</b>	Lets you view the assigned NetWare print mode <b>Note:</b> This can be changed only from the Embedded Web Server.
<b>Network Number</b>	Lets you view the assigned NetWare network number <b>Note:</b> This can be changed only from the Embedded Web Server.
<b>Select SAP Frames</b> Ethernet 802.2 Ethernet 802.3 Ethernet Type II Ethernet SNAP	Enables the Ethernet frame type setting <b>Note:</b> On is the factory default setting for all menu items.

Menu item	Description
<b>Packet Burst</b> Yes No	Reduces network traffic by allowing the transfer and acknowledgement of multiple data packets to and from the NetWare server <b>Note:</b> Yes is the factory default setting.
<b>NSQ/GSQ Mode</b> Yes No	Specifies the NSQ/GSQ Mode setting <b>Note:</b> Yes is the factory default setting.

## LexLink menu

This menu is available from the Network/Ports menu:

**Network/Ports → Standard Network or Network <x> → Std Network Setup or Net <x> Setup → LexLink menu**

Menu item	Description
<b>Activate</b> On Off	Activates LexLink support <b>Note:</b> Off is the factory default setting.
<b>View Nickname</b>	Lets you view the assigned LexLink nickname <b>Note:</b> The LexLink nickname can be changed only from the Embedded Web Server.

## Standard USB menu

Menu item	Description
<b>PCL SmartSwitch</b> On Off	Sets the printer to automatically switch to PCL emulation when a print job received through a USB port requires it, regardless of the default printer language <b>Notes:</b> <ul style="list-style-type: none"> <li>• On is the factory default setting.</li> <li>• When the Off setting is used, the printer does not examine incoming data.</li> <li>• When the Off setting is used, the printer uses PostScript emulation if the PS SmartSwitch setting is On. It uses the default printer language specified in the Setup menu if the PS SmartSwitch setting is Off.</li> </ul>
<b>PS SmartSwitch</b> On Off	Sets the printer to automatically switch to PS emulation when a print job received through a USB port requires it, regardless of the default printer language <b>Notes:</b> <ul style="list-style-type: none"> <li>• On is the factory default setting.</li> <li>• When the Off setting is used, the printer does not examine incoming data.</li> <li>• When the Off setting is used, the printer uses PCL emulation if the PCL SmartSwitch setting is On. It uses the default printer language specified in the Setup menu if the PCL SmartSwitch setting is Off.</li> </ul>

Menu item	Description
<b>NPA Mode</b> On Off Auto	Sets the printer to perform the special processing required for bidirectional communication following the conventions defined by the NPA protocol  <b>Notes:</b> <ul style="list-style-type: none"> <li>• Auto is the factory default setting.</li> <li>• Changing this setting from the printer control panel and then exiting the menus causes the printer to restart. The menu selection is updated.</li> </ul>
<b>USB Buffer</b> Disabled Auto 3K to <maximum size allowed>	Sets the size of the USB input buffer  <b>Notes:</b> <ul style="list-style-type: none"> <li>• Auto is the factory default setting.</li> <li>• The Disabled setting turns off job buffering. Any jobs already buffered on the disk are printed before normal processing is resumed.</li> <li>• The USB buffer size value can be changed in 1-K increments.</li> <li>• The maximum size allowed depends on the amount of memory in the printer, the size of the other link buffers, and whether the Resource Save setting is On or Off.</li> <li>• To increase the maximum size range for the USB Buffer, disable or reduce the size of the parallel, serial, and network buffers.</li> <li>• Changing this setting from the printer control panel and then exiting the menus causes the printer to restart. The menu selection is updated.</li> </ul>
<b>Job Buffering</b> Off On Auto	Temporarily stores jobs on the printer hard disk before printing  <b>Notes:</b> <ul style="list-style-type: none"> <li>• Off is the factory default setting.</li> <li>• The On setting buffers jobs on the printer hard disk.</li> <li>• The Auto setting buffers print jobs only if the printer is busy processing data from another input port.</li> <li>• Changing this setting from the printer control panel and then exiting the menus causes the printer to restart. The menu selection is updated.</li> </ul>
<b>Mac Binary PS</b> On Off Auto	Sets the printer to process Macintosh binary PostScript print jobs  <b>Notes:</b> <ul style="list-style-type: none"> <li>• Auto is the factory default setting.</li> <li>• The Off setting filters print jobs using the standard protocol.</li> <li>• The On setting processes raw binary PostScript print jobs.</li> </ul>
<b>USB With ENA</b> ENA Address ENA Netmask ENA Gateway	Sets the network address, netmask, or gateway information for an external print server that is attached to the printer using a USB cable.  <b>Note:</b> This menu item is available only if the printer is attached to an external print server through the USB port.

## Parallel <x> menu

This menu appears only if an optional parallel card is installed.

Menu item	Description
<b>PCL SmartSwitch</b> On Off	Sets the printer to automatically switch to PCL emulation when a print job received through a parallel port requires it, regardless of the default printer language <b>Notes:</b> <ul style="list-style-type: none"><li>• On is the factory default setting.</li><li>• When the Off setting is used, the printer does not examine incoming data.</li><li>• When the Off setting is used, the printer uses PostScript emulation if PS SmartSwitch is set to On. It uses the default printer language specified in the Setup menu if PS SmartSwitch is set to Off.</li></ul>
<b>PS SmartSwitch</b> On Off	Sets the printer to automatically switch to PS emulation when a print job received through a parallel port requires it, regardless of the default printer language <b>Notes:</b> <ul style="list-style-type: none"><li>• On is the factory default setting.</li><li>• When the Off setting is used, the printer does not examine incoming data.</li><li>• When the Off setting is used, the printer uses PCL emulation if PCL SmartSwitch is set to On. It uses the default printer language specified in the Setup menu if PCL SmartSwitch is set to Off.</li></ul>
<b>NPA Mode</b> On Off Auto	Sets the printer to perform the special processing required for bidirectional communication following the conventions defined by the NPA protocol <b>Notes:</b> <ul style="list-style-type: none"><li>• Auto is the factory default setting.</li><li>• Changing this setting from the printer control panel and then exiting the menus causes the printer to restart. The menu selection is updated.</li></ul>
<b>Parallel Buffer</b> Disabled Auto 3K to <max size allowed>	Sets the size of the parallel input buffer <b>Notes:</b> <ul style="list-style-type: none"><li>• Auto is the factory default setting.</li><li>• The Disabled setting turns off job buffering. Any jobs already buffered on the disk are printed before normal processing is resumed.</li><li>• The parallel buffer size setting can be changed in 1K increments.</li><li>• The maximum size allowed depends on the amount of memory in the printer, the size of the other link buffers, and whether Resource Save is set to On or Off.</li><li>• To increase the maximum size range for the Parallel Buffer, disable or reduce the size of the USB, serial, and network buffers.</li><li>• Changing this setting from the printer control panel and then exiting the menus causes the printer to restart. The menu selection is updated.</li></ul>

Menu item	Description
<b>Job Buffering</b> Off On Auto	Temporarily stores jobs on the printer hard disk before printing <b>Notes:</b> <ul style="list-style-type: none"> <li>• Off is the factory default setting.</li> <li>• The Off setting does not buffer print jobs to the printer hard disk.</li> <li>• The On setting buffers jobs on the printer hard disk.</li> <li>• The Auto setting buffers print jobs only if the printer is busy processing data from another input port.</li> <li>• Changing this setting from the printer control panel and then exiting the menus causes the printer to restart. The menu selection is updated.</li> </ul>
<b>Advanced Status</b> On Off	Enables bidirectional communication through the parallel port <b>Notes:</b> <ul style="list-style-type: none"> <li>• On is the factory default setting.</li> <li>• The Off setting disables parallel port negotiation.</li> </ul>
<b>Protocol</b> Standard Fastbytes	Specifies the parallel port protocol <b>Notes:</b> <ul style="list-style-type: none"> <li>• Fastbytes is the factory default setting. It provides compatibility with most existing parallel ports and is the recommended setting.</li> <li>• The Standard setting tries to resolve parallel port communication problems.</li> </ul>
<b>Honor Init</b> On Off	Determines whether or not the printer honors printer hardware initialization requests from the computer <b>Notes:</b> <ul style="list-style-type: none"> <li>• Off is the factory default setting.</li> <li>• The computer requests initialization by activating the Init signal from the parallel port. Many personal computers activate the Init signal each time the computer is turned on.</li> </ul>
<b>Parallel Mode 2</b> On Off	Determines whether the parallel port data is sampled on the leading or trailing edge of strobe <b>Notes:</b> <ul style="list-style-type: none"> <li>• On is the factory default setting.</li> <li>• This menu appears only if a standard or optional parallel port is available.</li> </ul>
<b>Mac Binary PS</b> On Off Auto	Sets the printer to process Macintosh binary PostScript print jobs <b>Notes:</b> <ul style="list-style-type: none"> <li>• Auto is the factory default setting.</li> <li>• The Off setting filters print jobs using the standard protocol.</li> <li>• The On setting processes raw binary PostScript print jobs.</li> </ul>
<b>Parallel With ENA</b> ENA Address ENA Netmask ENA Gateway	Sets the network address, netmask, or gateway information for an external print server that is attached to the printer using a parallel cable. <b>Note:</b> This menu item is available only if the printer is attached to an external print server through a parallel port.

## Serial <x> menu

This menu appears only if an optional serial card is installed.

Menu item	Description
<b>PCL SmartSwitch</b> On Off	Sets the printer to automatically switch to PCL emulation when a print job received through a serial port requires it, regardless of the default printer language  <b>Notes:</b> <ul style="list-style-type: none"> <li>• On is the factory default setting.</li> <li>• When the Off setting is used, the printer does not examine incoming data.</li> <li>• When the Off setting is used, the printer uses PostScript emulation if PS SmartSwitch is set to On. It uses the default printer language specified in the Setup menu if PS SmartSwitch is set to Off.</li> </ul>
<b>PS SmartSwitch</b> On Off	Sets the printer to automatically switch to PS emulation when a print job received through a serial port requires it, regardless of the default printer language  <b>Notes:</b> <ul style="list-style-type: none"> <li>• On is the factory default setting.</li> <li>• When the Off setting is used, the printer does not examine incoming data.</li> <li>• When the Off setting is used, the printer uses PCL emulation if PCL SmartSwitch is set to On. It uses the default printer language specified in the Setup menu if PCL SmartSwitch is set to Off.</li> </ul>
<b>NPA Mode</b> On Off Auto	Sets the printer to perform the special processing required for bidirectional communication following the conventions defined by the NPA protocol  <b>Notes:</b> <ul style="list-style-type: none"> <li>• Auto is the factory default setting.</li> <li>• When the On setting is used, the printer performs NPA processing. If the data is not in NPA format, it is rejected as bad data.</li> <li>• When the Off setting is used, the printer does not perform NPA processing.</li> <li>• When the Auto setting is used, the printer examines data, determines the format, and then processes it appropriately.</li> <li>• Changing this setting from the printer control panel and then exiting the menus causes the printer to restart. The menu selection is updated.</li> </ul>
<b>Serial Buffer</b> Disabled Auto 3K to <maximum size allowed>	Sets the size of the serial input buffer  <b>Notes:</b> <ul style="list-style-type: none"> <li>• Auto is the factory default setting.</li> <li>• The Disabled setting turns off job buffering. Any jobs already buffered on the disk are printed before normal processing is resumed.</li> <li>• The serial buffer size setting can be changed in 1-K increments.</li> <li>• The maximum size allowed depends on the amount of memory in the printer, the size of the other link buffers, and whether Resource Save is set to On or Off.</li> <li>• To increase the maximum size range for the Serial Buffer, disable or reduce the size of the parallel, USB, and network buffers.</li> <li>• Changing this setting from the printer control panel and then exiting the menus causes the printer to restart. The menu selection is updated.</li> </ul>

Menu item	Description
<b>Job Buffering</b> Off On Auto	Temporarily stores jobs on the printer hard disk before printing <b>Notes:</b> <ul style="list-style-type: none"> <li>• Off is the factory default setting.</li> <li>• The Off setting does not buffer print jobs to the hard disk.</li> <li>• The On setting buffers jobs on the printer hard disk.</li> <li>• The Auto setting buffers print jobs only if the printer is busy processing data from another input port.</li> <li>• Changing this setting from the printer control panel and then exiting the menus causes the printer to restart. The menu selection is updated.</li> </ul>
<b>Serial Protocol</b> DTR DTR/DSR XON/XOFF XON/XOFF/DTR XON/XOFF/DTRDSR	Selects the hardware and software handshaking settings for the serial port <b>Notes:</b> <ul style="list-style-type: none"> <li>• DTR is the factory default setting.</li> <li>• DTR/DSR is a hardware handshaking setting.</li> <li>• XON/XOFF is a software handshaking setting.</li> <li>• XON/XOFF/DTR and XON/XOFF/DTR/DSR are combined hardware and software handshaking settings.</li> </ul>
<b>Robust XON</b> On Off	Determines whether or not the printer communicates availability to the computer <b>Notes:</b> <ul style="list-style-type: none"> <li>• Off is the factory default setting.</li> <li>• This menu item applies only to the serial port if Serial Protocol is set to XON/XOFF.</li> </ul>
<b>Baud</b> 1200 2400 4800 9600 19200 38400 57600 115200 138200 172800 230400 345600	Specifies the rate at which data can be received through the serial port <b>Notes:</b> <ul style="list-style-type: none"> <li>• 9600 is the factory default setting.</li> <li>• 138200, 172800, 230400, and 345600 baud rates are displayed only in the Standard Serial menu. These settings do not appear in the Serial Option or Serial Option 2 menus.</li> </ul>
<b>Data Bits</b> 7 8	Specifies the number of data bits that are sent in each transmission frame <b>Note:</b> 8 is the factory default setting.



Menu item	Description
<b>Parity</b> Even Odd None Ignore	Sets the parity for serial input and output data frames <b>Note:</b> None is the factory default setting.
<b>Honor DSR</b> On Off	Determines whether the printer uses the DSR Signal. DSR is a handshaking signal used by most serial cables. <b>Notes:</b> <ul style="list-style-type: none"> <li>• Off is the factory default setting.</li> <li>• The serial port uses DSR to distinguish data sent by the computer from data created by electrical noise in the serial cable. The electrical noise can cause stray characters to print. Select <b>On</b> to prevent stray characters from printing.</li> <li>• This menu item appears only if Serial RS-232/RS-422 is set to RS 232.</li> </ul>

## Security menu

### Miscellaneous menu

Menu item	Description
<b>Panel Logins</b> Login failures Failure time frame Lockout time Login timeout	Limits the number and time frames of failed login attempts from the printer control panel before <i>all</i> users are locked out <b>Notes:</b> <ul style="list-style-type: none"> <li>• “Login failures” specifies the number of failed login attempts before users are locked out. Settings range from 1–50. 3 attempts is the factory default setting.</li> <li>• “Failure time frame” specifies the time frame during which failed login attempts can be made before users are locked out. Settings range from 1–60 minutes. 5 minutes is the factory default setting.</li> <li>• “Lockout time” specifies how long users are locked out after exceeding the login failures limit. Settings range from 0–60 minutes. 5 minutes is the factory default setting. 0 indicates the printer does not impose a lockout time.</li> <li>• “Login timeout” specifies how long the printer remains idle on the Home screen before automatically logging the user off. Settings range from 1–900 seconds. 300 seconds is the factory default setting.</li> </ul>

Menu item	Description
<b>Remote Logins</b> Login failures Failure time frame Lockout time Login timeout	Limits the number and time frames of failed login attempts from a computer before <i>all</i> remote users are locked out  <b>Notes:</b> <ul style="list-style-type: none"> <li>• “Login failures” specifies the number of failed login attempts before users are locked out. Settings range from 1–50. 3 attempts is the factory default setting.</li> <li>• “Failure time frame” specifies the time frame during which failed login attempts can be made before users are locked out. Settings range from 1–60 minutes. 5 minutes is the factory default setting.</li> <li>• “Lockout time” specifies how long a user is locked out after exceeding the login failures limit. Settings range from 0–60 minutes. 5 minutes is the factory default setting. 0 indicates the printer does not impose a lockout time.</li> <li>• “Login timeout” specifies how long the remote interface remains idle before automatically logging the user off. Settings range from 1–900 seconds. 300 seconds is the factory default setting.</li> </ul>

## Confidential Print menu

Menu item	Description
<b>Max Invalid PIN</b> Off 2–10	Limits the number of times an invalid PIN can be entered  <b>Notes:</b> <ul style="list-style-type: none"> <li>• Off is the default setting.</li> <li>• This menu item appears only if a printer hard disk is installed.</li> <li>• Once a limit is reached, the jobs for that user name and that PIN are deleted.</li> </ul>
<b>Job Expiration</b> Off 1 hour 4 hours 24 hours 1 week	Limits the amount of time a confidential job stays in the printer before it is deleted  <b>Notes:</b> <ul style="list-style-type: none"> <li>• Off is the default setting.</li> <li>• If the Job Expiration setting is changed while confidential jobs reside on the printer RAM or printer hard disk, the expiration time for those print jobs does not change to the new default value.</li> <li>• If the printer is turned off, all confidential jobs held in printer RAM are deleted.</li> </ul>

## Disk Wiping menu

Menu item	Description
<p><b>Automatic Wiping</b></p> <p>Off</p> <p>On</p>	<p>Disk Wiping erases <i>only</i> print job data that <i>is not</i> currently in use by the file system from the printer hard disk. All permanent data on the printer hard disk is preserved, such as downloaded fonts, macros, and held jobs.</p> <p>Automatic Wiping marks all disk space used by a previous job and does not permit the file system to reuse this space until it has been sanitized.</p> <p>Only Automatic Wiping enables users to activate disk wiping without having to take the printer offline for an extended amount of time.</p> <p><b>Notes:</b></p> <ul style="list-style-type: none"> <li>• This menu item appears only if a formatted, non-defective printer hard disk is installed.</li> <li>• Off is the default setting.</li> <li>• Due to the large amount of resources required for Automatic Wiping, activating this option may decrease printer performance, especially if the printer requires hard disk space faster than it can be wiped and returned to service.</li> </ul>
<p><b>Manual Wiping</b></p> <p>Start now</p> <p>Do not start now</p>	<p>Disk Wiping erases <i>only</i> print job data that <i>is not</i> currently in use by the file system from the printer hard disk. All permanent data on the printer hard disk is preserved, such as downloaded fonts, macros, and held jobs.</p> <p>Manual Wiping overwrites all disk space that has been used to hold data from a print job that has been processed (i.e. printed). This type of wipe <i>does not</i> erase any information related to an unprocessed print job.</p> <p><b>Notes:</b></p> <ul style="list-style-type: none"> <li>• This menu item appears only if a formatted, non-defective printer hard disk is installed.</li> <li>• "Do not start now" is the default setting.</li> <li>• If the Disk Wiping access control is activated, then a user must successfully authenticate and have the required authorization in order to initiate the disk wipe.</li> </ul>
<p><b>Automatic Method</b></p> <p>Single pass</p> <p>Multiple pass</p>	<p>Disk Wiping erases <i>only</i> print job data that <i>is not</i> currently in use by the file system from the printer hard disk. All permanent data on the printer hard disk is preserved, such as downloaded fonts, macros, and held jobs.</p> <p><b>Notes:</b></p> <ul style="list-style-type: none"> <li>• This menu item appears only if a formatted, non-defective printer hard disk is installed.</li> <li>• Single pass is the default setting.</li> <li>• Highly confidential information should be wiped using the Multiple pass method <i>only</i>.</li> </ul>

Menu item	Description
<b>Manual Method</b> Single pass Multiple pass	<p>Disk Wiping erases <i>only</i> print job data that <i>is not</i> currently in use by the file system from the printer hard disk. All permanent data on the printer hard disk is preserved, such as downloaded fonts, macros, and held jobs.</p> <p>Both manual and scheduled wiping allow the file system to reuse marked disk space without first having to wipe it.</p> <p><b>Notes:</b></p> <ul style="list-style-type: none"> <li>• This menu item appears only if a formatted, non-defective printer hard disk is installed.</li> <li>• Single pass is the default setting.</li> <li>• Highly confidential information should be wiped using the Multiple Pass method <i>only</i>.</li> </ul>
<b>Scheduled Method</b> Single pass Multiple pass	<p>Disk Wiping erases <i>only</i> print job data that <i>is not</i> currently in use by the file system from the printer hard disk. All permanent data on the printer hard disk is preserved, such as downloaded fonts, macros, and held jobs.</p> <p>Both manual and scheduled wiping allow the file system to reuse marked disk space without first having to wipe it.</p> <p><b>Notes:</b></p> <ul style="list-style-type: none"> <li>• This menu item appears only if a formatted, non-defective printer hard disk is installed.</li> <li>• Single pass is the default setting.</li> <li>• Highly confidential information should be wiped using the Multiple Pass method <i>only</i>.</li> <li>• Scheduled wipes are initiated <i>without</i> displaying a user warning or confirmation message.</li> </ul>

## Security Audit Log menu

Menu item	Description
<b>Export Log</b>	<p>Enables an authorized user to export the security log</p> <p><b>Notes:</b></p> <ul style="list-style-type: none"> <li>• To export the log from the printer control panel, a flash drive must be attached to the printer.</li> <li>• From the Embedded Web Server, the log can be downloaded to a computer.</li> </ul>
<b>Delete Log</b> Delete now Do not delete	<p>Specifies whether audit logs are deleted</p> <p><b>Note:</b> Delete Now is the factory default setting.</p>
<b>Configure Log</b> Enable Audit Enable Remote Syslog Remote Syslog Facility Severity of events to log	<p>Specifies whether and how the audit logs are created</p> <p><b>Note:</b> Factory default settings enable the security audit log.</p>

## Set Date/Time menu

Menu item	Description
<b>View Date/Time</b>	Lets you view the current date and time settings for the printer
<b>Set Date/Time</b> <input date/time>	<b>Note:</b> Date/Time is set in YYYY-MM-DD HH:MM format.
<b>Time Zone</b> <list of time zones>	<b>Note:</b> GMT is the factory default setting.
<b>Observe DST</b> On Off	<b>Note:</b> On is the factory default setting and uses the applicable Daylight Saving Time associated with the Time Zone setting.
<b>Enable NTP</b> On Off	Enables Network Time Protocol, which synchronizes the clocks of devices on a network <b>Note:</b> On is the factory default setting.

## Settings menu

### General Settings menu

Menu item	Description
<b>Display Language</b> English Francais Deutsch Italiano Espanol Dansk Norsk Nederlands Svenska Portuguese Suomi Russian Polski Magyar Turkce Cesky Simplified Chinese Traditional Chinese Korean Japanese	Sets the language of the text appearing on the display <b>Note:</b> All languages may not be available for all printers.

Menu item	Description
<b>Eco-Mode</b> Off Energy Energy/Paper Paper	Minimizes the use of energy, paper, or specialty media <b>Notes:</b> <ul style="list-style-type: none"> <li>• Off is the factory default setting. Off resets the printer to its factory default settings.</li> <li>• The Energy setting minimizes the power used by the printer. Performance may be affected but not print quality.</li> <li>• Paper minimizes the amount of paper and specialty media needed for a print job by duplexing each page. Performance may be affected but not print quality.</li> <li>• Energy/Paper minimizes the use of power and of paper and specialty media.</li> </ul>
<b>ADF Loaded Beep</b> Enabled Disabled	Specifies whether the ADF emits a beep when paper is loaded <b>Note:</b> Disabled is the factory default setting.
<b>Quiet Mode</b> Off On	Reduces the amount of noise produced by the printer <b>Notes:</b> <ul style="list-style-type: none"> <li>• Off is the factory default setting.</li> <li>• On configures the printer to produce as little noise as possible.</li> </ul>
<b>Run Initial setup</b> Yes No	Instructs the printer to run the setup wizard <b>Notes:</b> <ul style="list-style-type: none"> <li>• Yes is the factory default setting.</li> <li>• After completing the setup wizard by selecting Done at the Country select screen, the default becomes No.</li> </ul>

Menu item	Description
<p><b>Keyboard</b></p> <ul style="list-style-type: none"> <li>Keyboard Type <ul style="list-style-type: none"> <li>English</li> <li>Francais</li> <li>Francais Canadien</li> <li>Deutsch</li> <li>Italiano</li> <li>Espanol</li> <li>Dansk</li> <li>Norsk</li> <li>Nederlands</li> <li>Svenska</li> <li>Suomi</li> <li>Portuguese</li> <li>Russian</li> <li>Polski</li> <li>Swiss German</li> <li>Swiss French</li> <li>Turkce</li> <li>Korean</li> </ul> </li> <li>Custom Key &lt;x&gt;</li> <li>Accents/Symbols Tab <ul style="list-style-type: none"> <li>On</li> <li>Off</li> </ul> </li> <li>Russian/Polish Tab <ul style="list-style-type: none"> <li>On</li> <li>Off</li> </ul> </li> <li>Korean Tab <ul style="list-style-type: none"> <li>On</li> <li>Off</li> </ul> </li> </ul>	<p>Specifies a language and custom key information for the printer control panel keyboard. The additional tabs enable access to accent marks and symbols from the printer control panel keyboard.</p>
<p><b>Paper Sizes</b></p> <ul style="list-style-type: none"> <li>U.S.</li> <li>Metric</li> </ul>	<p>Specifies the printer factory default measurements. The default is determined by the country/region selection in the initial setup wizard.</p>
<p><b>Scan to PC Port Range</b></p> <p>&lt;port range&gt;</p>	<p>Specifies a valid port range for printers behind a port blocking firewall. The valid ports are specified by two sets of numbers separated by a semicolon.</p> <p><b>Note:</b> 9751:12000 is the factory default setting.</p>

Menu item	Description
<p><b>Displayed Information</b></p> <p>Left side</p> <p>Right side</p> <p>Custom Text &lt;x&gt;     &lt;text entry&gt;</p> <p>Black Toner</p> <p>    Display When Supply Registers</p> <p>        Off</p> <p>        Early Warning</p> <p>        Low</p> <p>        Near End of Life</p> <p>        End of Life</p> <p>    Type of Message to Display</p> <p>        Default</p> <p>        Alternate</p> <p>    Default Message</p> <p>        &lt;text entry&gt;</p> <p>    Alternate Message</p> <p>        &lt;text entry&gt;</p>	<p>Specifies what is displayed on the upper left and right corners of the home screen</p> <p>For the Left side and Right side options, choose from the following options:</p> <ul style="list-style-type: none"> <li>None</li> <li>IP Address</li> <li>Hostname</li> <li>Contact Name</li> <li>Location</li> <li>Date/Time</li> <li>mDNS/DDNS Service Name</li> <li>Zero Configuration Name</li> <li>Cartridge Level</li> <li>Custom Text &lt;x&gt;</li> </ul> <p><b>Notes:</b></p> <ul style="list-style-type: none"> <li>• IP Address is the factory default setting for Left side.</li> <li>• Date/Time is the factory default setting for Right side.</li> <li>• Off is the factory default setting for Display When Supply Registers.</li> <li>• Default is the factory default setting for Type of Message to Display.</li> </ul>
<p><b>Displayed Information (continued)</b></p> <p>Paper Jam</p> <p>Load Paper</p> <p>Service Errors</p>	<p>The displayed information for Paper Jam, Load Paper, and Service Errors can be customized with the following options:</p> <ul style="list-style-type: none"> <li>Activate</li> <li>    Yes</li> <li>    No</li> <li>Type of Message to Display</li> <li>    Default</li> <li>    Alternate</li> <li>Default Message</li> <li>    &lt;text entry&gt;</li> <li>Alternate Message</li> <li>    &lt;text entry&gt;</li> </ul> <p><b>Notes:</b></p> <ul style="list-style-type: none"> <li>• No is the factory default setting for Activate.</li> <li>• Default is the factory default setting for Type of Message to Display.</li> </ul>



Menu item	Description
<p><b>Home screen customization</b></p> <ul style="list-style-type: none"> <li>Change Language</li> <li>Copy</li> <li>Copy Shortcuts</li> <li>Fax</li> <li>Fax Shortcuts</li> <li>E-mail</li> <li>E-mail Shortcuts</li> <li>FTP</li> <li>FTP Shortcuts</li> <li>Search Held Jobs</li> <li>Held Jobs</li> <li>USB Drive</li> <li>Profiles</li> <li>Bookmarks</li> <li>Jobs by user</li> </ul>	<p>Additional buttons can be added to the Home screen, and default buttons can be removed.</p> <p>Available selections for each button are:</p> <ul style="list-style-type: none"> <li>Display</li> <li>Do Not Display</li> </ul>
<p><b>Date Format</b></p> <ul style="list-style-type: none"> <li>MM-DD-YYYY</li> <li>DD-MM-YYYY</li> <li>YYYY-MM-DD</li> </ul>	<p>Formats the printer date</p>
<p><b>Time Format</b></p> <ul style="list-style-type: none"> <li>12 hour A.M./P.M.</li> <li>24 hour clock</li> </ul>	<p>Formats the printer time</p>
<p><b>Screen Brightness</b></p> <ul style="list-style-type: none"> <li>20–100</li> </ul>	<p>Specifies the brightness of the printer control panel screen</p>
<p><b>One Page Copy</b></p> <ul style="list-style-type: none"> <li>On</li> <li>Off</li> </ul>	<p>Sets the copies from the scanner glass to only one page at a time</p> <p><b>Note:</b> Off is the factory default setting.</p>

Menu item	Description
<p><b>Output Lighting</b></p> <p>Standard Bin LED</p> <ul style="list-style-type: none"> <li>Normal/Standby Mode <ul style="list-style-type: none"> <li>Bright</li> <li>Dim</li> <li>Off</li> </ul> </li> <li>Power Saver <ul style="list-style-type: none"> <li>Bright</li> <li>Dim</li> <li>Off</li> </ul> </li> </ul> <p>Output Option Bin LEDs</p> <ul style="list-style-type: none"> <li>Normal/Standby Mode <ul style="list-style-type: none"> <li>Bright</li> <li>Dim</li> <li>Off</li> </ul> </li> <li>Power Saver <ul style="list-style-type: none"> <li>Bright</li> <li>Dim</li> <li>Off</li> </ul> </li> </ul>	<p>Sets the amount of light from the standard bin or an optional output bin</p> <p><b>Notes:</b></p> <ul style="list-style-type: none"> <li>• In Normal/Standby Mode, the factory default is Bright.</li> <li>• In Power Saver Mode, the factory default is Dim.</li> </ul>
<p><b>Show Bookmarks</b></p> <ul style="list-style-type: none"> <li>On</li> <li>Off</li> </ul>	<p>Specifies whether bookmarks are displayed from the Held Jobs area</p> <p><b>Note:</b> On is the factory default setting. When On is selected, bookmarks appear in the Held Jobs area.</p>
<p><b>Allow Background Removal</b></p> <ul style="list-style-type: none"> <li>On</li> <li>Off</li> </ul>	<p>Specifies whether image background removal is allowed during copy, fax, e-mail, FTP, or scan to USB</p> <p><b>Note:</b> On is the factory default setting. The background of the image will be removed.</p>
<p><b>Allow Custom Job Scans</b></p> <ul style="list-style-type: none"> <li>On</li> <li>Off</li> </ul>	<p>Lets you scan multiple jobs to one file</p> <p><b>Note:</b> On is the factory default setting. If On is selected, the Allow Custom Job Scans setting can be enabled for specific jobs.</p>
<p><b>Scanner Jam Recovery</b></p> <ul style="list-style-type: none"> <li>Job level</li> <li>Page level</li> </ul>	<p>Specifies how a scanned job should be reloaded if a paper jam occurs in the ADF</p> <p><b>Notes:</b></p> <ul style="list-style-type: none"> <li>• If Job level is selected, the entire job must be rescanned if any pages jam.</li> <li>• If Page level is selected, rescan from the jammed page forward.</li> </ul>
<p><b>Web Page Refresh Rate</b></p> <p>30–300</p>	<p>Specifies the number of seconds between Embedded Web Server refreshes</p> <p><b>Note:</b> 120 seconds is the factory default setting.</p>
<p><b>Contact Name</b></p>	<p>Specifies a contact name for the printer</p> <p><b>Note:</b> The contact name will be stored on the Embedded Web Server.</p>

Menu item	Description
<b>Location</b>	Specifies the location of the printer <b>Note:</b> The location will be stored on the Embedded Web Server.
<b>Alarms</b> Alarm Control Cartridge Alarm Staple Alarm	Sets an alarm to sound when the printer requires operator intervention Available selections for each alarm type are: Off Single Continuous <b>Notes:</b> <ul style="list-style-type: none"> <li>• Single is the factory default setting for Alarm Control. Single sounds three quick beeps.</li> <li>• Off is the factory default setting for Toner Alarm and Staple Alarm. Off means no alarm will sound.</li> <li>• Continuous repeats three beeps every 10 seconds.</li> <li>• Staple Alarm is available only when the finisher is installed.</li> </ul>
<b>Timeouts</b> Job Hold Timeout Disabled 5–255	Sets the amount of time the printer waits for user intervention before it holds jobs that require unavailable resources and continues to print other jobs in the print queue <b>Notes:</b> <ul style="list-style-type: none"> <li>• 30 seconds is the factory default setting.</li> <li>• This menu item appears only when a printer hard disk is installed.</li> </ul>
<b>Timeouts</b> Standby Mode Disabled 2–240	Specifies the number of minutes of inactivity before the system enters a lower power state <b>Note:</b> 15 minutes is the factory default setting.
<b>Timeouts</b> Power Saver Mode Disabled 2–240	Specifies the number of minutes of inactivity before some systems begin entering a minimum power state. <b>Notes:</b> <ul style="list-style-type: none"> <li>• 60 minutes is the factory default setting.</li> <li>• Power Saver does not interact with Standby Mode.</li> </ul>
<b>Timeouts</b> Screen Timeout 15–300	Sets the amount of time in seconds the printer waits before returning the printer display to a <b>Ready</b> state <b>Note:</b> 30 seconds is the factory default setting.

Menu item	Description
<b>Timeouts</b> Print Timeout Disabled 1–255	Sets the amount of time in seconds the printer waits to receive an end-of-job message before canceling the remainder of the print job  <b>Notes:</b> <ul style="list-style-type: none"> <li>• 90 seconds is the factory default setting.</li> <li>• When the timer expires, any partially printed page still in the printer is printed, and then the printer checks to see if any new print jobs are waiting.</li> <li>• Print Timeout is available only when using PCL or PPDS emulation. This setting has no effect on PostScript emulation print jobs.</li> </ul>
<b>Timeouts</b> Wait Timeout Disabled 15–65535	Sets the amount of time in seconds the printer waits for additional data before canceling a print job  <b>Notes:</b> <ul style="list-style-type: none"> <li>• 40 seconds is the factory default setting.</li> <li>• Wait Timeout is available only when the printer is using PostScript emulation. This setting has no effect on PCL or PPDS emulation print jobs.</li> </ul>
<b>Print Recovery</b> Auto Continue Disabled 5–255	Lets the printer automatically continue printing from certain offline situations when not resolved within the specified time period  <b>Notes:</b> <ul style="list-style-type: none"> <li>• Disabled is the factory default setting.</li> <li>• 5–255 is a range of time in seconds.</li> </ul>
<b>Print Recovery</b> Jam Recovery On Off Auto	Specifies whether the printer reprints jammed pages  <b>Notes:</b> <ul style="list-style-type: none"> <li>• Auto is the factory default setting. The printer reprints jammed pages unless the memory required to hold the pages is needed for other printer tasks.</li> <li>• On sets the printer to always reprint jammed pages.</li> <li>• Off sets the printer to never reprint jammed pages.</li> </ul>
<b>Print Recovery</b> Page Protect On Off	Lets the printer successfully print a page that may not have printed otherwise  <b>Notes:</b> <ul style="list-style-type: none"> <li>• Off is the factory default setting. Off prints a partial page when there is not enough memory to print the whole page.</li> <li>• On sets the printer to process the whole page so that the entire page prints.</li> </ul>

Menu item	Description
<b>Factory Defaults</b> Do Not Restore Restore Now	Returns the printer settings to the factory default settings  <b>Notes:</b> <ul style="list-style-type: none"> <li>• Do Not Restore is the factory default setting. Do Not Restore keeps the user-defined settings.</li> <li>• Restore returns all printer settings to the factory default settings except Network/Ports menu settings. All downloads stored in RAM are deleted. Downloads stored in flash memory or on a printer hard disk are not affected.</li> </ul>

## Copy Settings menu

Menu item	Description
<b>Content</b> Text/Photo Photograph Printed Image Text	Specifies the type of content contained in the copy job  <b>Notes:</b> <ul style="list-style-type: none"> <li>• Text/Photo is the factory default setting. Text/Photo is used when the original documents are a mixture of text and graphics or pictures.</li> <li>• Photograph tells the scanner to pay extra attention to graphics and pictures. This setting increases the time it takes to scan, but emphasizes a reproduction of the full dynamic range of tones in the original document. This increases the amount of information saved.</li> <li>• Printed Image is used when jobs are composed primarily of images. Printed Image converts the images to halftone. Halftoning makes a grayscale or color image printable by transforming it to a pattern of small spots with a limited number of colors.</li> <li>• Text emphasizes sharp, black, high-resolution text against a clean, white background.</li> </ul>
<b>Sides (Duplex)</b> 1 sided to 1 sided 1 sided to 2 sided 2 sided to 1 sided 2 sided to 2 sided	Specifies whether an original document is duplex (two-sided) or simplex (one-sided), and then specifies whether the copy should be duplex or simplex  <b>Notes:</b> <ul style="list-style-type: none"> <li>• <b>1 sided to 1 sided</b>—The original page has printing on one side. The copied page will have printing on one side.</li> <li>• <b>1 sided to 2 sided</b>—The original page has printing on one side. The copied page will have printing on both sides. For example, if the original is six sheets, the copy is three sheets with printing on both sides.</li> <li>• <b>2 sided to 1 sided</b>—The original page has printing on both sides. The copied page will have printing on only one side. For example, if the original draft is three sheets of paper with an image on each side of each sheet, then the copy is six sheets with only one image on one side of each sheet.</li> <li>• <b>2 sided to 2 sided</b>—The original page has printing on both sides. The copy mimics the original exactly.</li> </ul>

Menu item	Description
<b>Paper Saver</b> Off 2 on 1 Portrait 2 on 1 Landscape 4 on 1 Portrait 4 on 1 Landscape	Sets two or four sheets of an original document together on the same page <b>Note:</b> Off is the factory default setting.
<b>Print Page Borders</b> On Off	Specifies whether a border is printed around the edge of the page at the margins <b>Note:</b> On is the factory default setting.
<b>Collate</b> On Off	Keeps the pages of a print job stacked in sequence when making multiple copies of the job <b>Note:</b> On is the factory default setting.
<b>Staple</b> On Off	Enables stapling <b>Note:</b> Off is the factory default setting.
<b>Original Size</b> Letter Legal Executive Folio Statement Universal 4 x 6 in. 3 x 5 in. Business Card Custom Scan Size <x> A4 A5 Oficio (Mexico) A6 JIS B5 Book Original Auto Size Sense Mixed Letter/Legal	Specifies the paper size of the original document
<b>Copy To Source</b> Tray <x> Single Sheet Feeder Multi Sheet Feeder Auto Size Match	Specifies the paper source for copy jobs <b>Note:</b> Tray 1 is the factory default setting.
<b>Transparency Separators</b> On Off	Places a sheet of paper between transparencies <b>Note:</b> On is the factory default setting.

Menu item	Description
<b>Separator Sheets</b> None Between Copies Between Jobs Between Pages	Places a sheet of paper between pages, copies, or jobs based on the value selected <b>Note:</b> None is the factory default setting.
<b>Separator Source</b> Tray <x> Manual Feeder Envelope Feeder	Specifies a paper source
<b>Darkness</b> 1–9	Specifies the level of darkness for the copy job
<b>Output Bin</b> Standard Bin Bin <x>	Specifies which output bin receives the copy after it is printed
<b>Number of Copies</b>	Specifies the number of copies for the copy job
<b>Header/Footer</b> Top left Top left Off Date/Time Page number Bates number Custom text Print on All pages First page only All but first page Enter custom text	Specifies header/footer information for the top left of the page <b>Notes:</b> <ul style="list-style-type: none"> <li>• Off is the factory default setting for Top left.</li> <li>• “All pages” is the factory default setting for Print on.</li> </ul>
<b>Header/Footer</b> Top middle Top middle Off Date/Time Page number Bates number Custom text Print on All pages First page only All but first page Enter custom text	Specifies header/footer information for the middle of the page <b>Notes:</b> <ul style="list-style-type: none"> <li>• Off is the factory default setting for Top middle.</li> <li>• “All pages” is the factory default setting for Print on.</li> </ul>

Menu item	Description
<p><b>Header/Footer</b></p> <p>Top right</p> <p>    Top right</p> <p>    Off</p> <p>    Date/Time</p> <p>    Page number</p> <p>    Bates number</p> <p>    Custom text</p> <p>Print on</p> <p>    All pages</p> <p>    First page only</p> <p>    All but first page</p> <p>Enter custom text</p>	<p>Specifies header/footer information for the top right of the page</p> <p><b>Notes:</b></p> <ul style="list-style-type: none"> <li>• Off is the factory default setting for Top right.</li> <li>• “All pages” is the factory default setting for Print on.</li> </ul>
<p><b>Header/Footer</b></p> <p>Bottom left</p> <p>    Bottom left</p> <p>    Off</p> <p>    Date/Time</p> <p>    Page number</p> <p>    Bates number</p> <p>    Custom text</p> <p>Print on</p> <p>    All pages</p> <p>    First page only</p> <p>    All but first page</p> <p>Enter custom text</p>	<p>Specifies header/footer information for the bottom left of the page</p> <p><b>Notes:</b></p> <ul style="list-style-type: none"> <li>• Off is the factory default setting for Bottom left.</li> <li>• “All pages” is the factory default setting for Print on.</li> </ul>
<p><b>Header/Footer</b></p> <p>Bottom middle</p> <p>    Bottom middle</p> <p>    Off</p> <p>    Date/Time</p> <p>    Page number</p> <p>    Bates number</p> <p>    Custom text</p> <p>Print on</p> <p>    All pages</p> <p>    First page only</p> <p>    All but first page</p> <p>Enter custom text</p>	<p>Specifies header/footer information for the bottom middle of the page</p> <p><b>Notes:</b></p> <ul style="list-style-type: none"> <li>• Off is the factory default setting for Bottom middle.</li> <li>• “All pages” is the factory default setting for Print on.</li> </ul>



Menu item	Description
<b>Header/Footer</b> Bottom right Bottom right Off Date/Time Page number Bates number Custom text Print on All pages First page only All but first page Enter custom text	Specifies header/footer information for the bottom right of the page <b>Notes:</b> <ul style="list-style-type: none"> <li>• Off is the factory default setting for Bottom right.</li> <li>• “All pages” is the factory default setting for Print on.</li> </ul>
<b>Overlay</b> Off Confidential Copy Draft Urgent Custom	Specifies overlay text that is printed on each page of the copy job <b>Note:</b> Off is the factory default setting.
<b>Custom Overlay</b>	Specifies custom overlay text
<b>Allow priority copies</b> On Off	Allows interruption of a print job to copy a page or document <b>Note:</b> On is the factory default setting.
<b>Custom Job scanning</b> On Off	Lets you copy in a single copy job a document that contains mixed paper sizes
<b>Allow Save as Shortcut</b> On Off	Lets you save custom copy settings as shortcuts <b>Note:</b> On is the factory default setting.
<b>Background Removal</b> -4 to +4	Adjusts the amount of background visible on a copy
<b>Auto Center</b> On Off	Lets you automatically center the copy on the page <b>Note:</b> Off is the factory default setting.

Menu item	Description
<b>Color Dropout</b> Color Dropout None Red Green Blue Default Red Threshold 0–255 Default Green Threshold 0–255 Default Blue Threshold 0–255	Specifies which color to drop during copies, and how much to increase or decrease the dropout <b>Notes:</b> <ul style="list-style-type: none"> <li>• None is the factory default setting for Color Dropout.</li> <li>• 128 is the factory default setting for each color threshold.</li> </ul>
<b>Contrast</b> 0–5 Best for content	Specifies the contrast used for the copy job <b>Note:</b> Best for content is the factory default setting.
<b>Mirror Image</b> On Off	Creates a mirror image of the original document <b>Note:</b> Off is the factory default setting.
<b>Negative Image</b> On Off	Creates a negative image of the original document <b>Note:</b> Off is the factory default setting.
<b>Shadow Detail</b> 0–4	Adjusts the amount of shadow detail visible on a copy <b>Note:</b> 0 is the factory default setting.
<b>Scan edge to edge</b> On Off	Specifies if the original document is scanned edge-to-edge prior to copying <b>Note:</b> Off is the factory default setting.
<b>Sharpness</b> 0–5	Adjusts the amount of sharpness on a copy <b>Note:</b> 3 is the factory default setting.
<b>Sample Copy</b> On Off	Creates a sample copy of the original document <b>Note:</b> Off is the factory default setting.

## Fax Settings menu

### Fax Mode (Analog Fax Setup) menu

Analog Fax Setup mode sends the fax job by way of a telephone line.

## General Fax Settings

Menu item	Description
<b>Fax Cover Page</b> Fax Cover Page Off by default On by default Never Use Always Use Include To field On Off Include From field On Off From Include Message field On Off Message Include Logo On Off Include Footer <x> Footer <x>	Configures the fax cover page <b>Note:</b> Off is the factory default setting for all Fax Cover Page options.
<b>Station Name</b>	Specifies the name of the fax within the printer
<b>Station Number</b>	Specifies a number associated with the fax
<b>Station ID</b> Station Name Station Number	Specifies how the fax is identified
<b>Enable Manual Fax</b> On Off	Sets the printer to fax manually only, which requires a line splitter and a telephone hand set <b>Notes:</b> <ul style="list-style-type: none"> <li>• Use a regular telephone to answer an incoming fax job and to dial a fax number.</li> <li>• Touch # 0 on the numeric keypad to go directly to the Manual Fax function.</li> </ul>
<b>Memory Use</b> All receive Mostly receive Equal Mostly sent All send	Defines the allocation of non-volatile memory between sending and receiving fax jobs <b>Notes:</b> <ul style="list-style-type: none"> <li>• “All receive” specifies that all the memory is set to receive fax jobs.</li> <li>• “Mostly receive” specifies that most of the memory is set to receive fax jobs.</li> <li>• Equal is the factory default setting. Equal splits the memory for sending and receiving fax jobs into equal amounts.</li> <li>• “Mostly sent” specifies that most of the memory is set to send fax jobs.</li> <li>• “All send” specifies that all the memory is set to send fax jobs.</li> </ul>

Menu item	Description
<b>Cancel Faxes</b> Allow Don't Allow	Specifies whether the printer may cancel fax jobs <b>Note:</b> If Cancel Faxes is not enabled, it will not appear as an option.
<b>Caller ID</b> FSK DTMF	Specifies type of caller ID being used <b>Note:</b> FSK is the factory default setting.
<b>Fax number masking</b> Off From left From right	Specifies the direction from which digits are masked in an outgoing fax number <b>Note:</b> The number of characters masked is determined by the "Digits to mask" setting.
<b>Digits to mask</b> 0-58	Specifies the number of digits to mask in an outgoing fax number

## Fax Send Settings

Menu item	Description
<b>Resolution</b> Standard Fine Super Fine Ultra Fine	Specifies quality in dots per inch (dpi). A higher resolution gives greater print quality, but it increases the fax transmission time for outgoing faxes. <b>Note:</b> Standard is the factory default setting.
<b>Original Size</b> Letter Legal Executive Folio Statement Universal 4 x 6 in. 3 x 5 in. Business Card Custom Scan Size <x> A4 A5 Oficio (Mexico) A6 JIS B5 Book Original Auto Size Sense Mixed Letter/Legal	Specifies the paper size of the document that is being scanned <b>Note:</b> Letter is the US factory default setting. A4 is the international factory default setting.

Menu item	Description
<b>Sides (Duplex)</b> Off Long edge Short edge	Specifies how the text and graphics are oriented on the page <b>Notes:</b> <ul style="list-style-type: none"> <li>• Off is the factory default setting.</li> <li>• Long edge assumes binding along the long edge of the page (left edge for portrait orientation and top edge for landscape orientation).</li> <li>• Short edge assumes binding along the short edge of the page (top edge for portrait orientation and left edge for landscape orientation).</li> </ul>
<b>Content</b> Text Text/Photo Photograph	Specifies the type of content that will be scanned to fax <b>Notes:</b> <ul style="list-style-type: none"> <li>• Text is used when the document is mostly text.</li> <li>• Text/Photo is the factory default setting. Text/Photo is used when the documents are mostly text or line art.</li> <li>• Photograph is used when the document is a high-quality photograph or inkjet print.</li> </ul>
<b>Darkness</b> 1–9	Lightens or darkens the output <b>Note:</b> 5 is the factory default setting.
<b>Dial Prefix</b>	A numeric entry field is provided to enter numbers
<b>Dialing Prefix Rules</b> Prefix Rule <x>	Establishes a dialing prefix rule
<b>Automatic Redial</b> 0–9	Specifies the number of times the printer tries to send the fax to a specified number <b>Note:</b> 5 is the factory default setting.
<b>Redial Frequency</b> 1–200	Specifies the number of minutes between redials
<b>Behind a PABX</b> Off On	Enables switchboard blind dialing without a dial tone
<b>Enable ECM</b> On Off	Enables Error Correction Mode for fax jobs
<b>Enable Fax Scans</b> On Off	Lets you send faxes by scanning at the printer
<b>Driver to fax</b> On Off	Allows driver to fax jobs to be sent by the printer
<b>Allow Save as Shortcut</b> On Off	Lets you save fax numbers as shortcuts in the printer

Menu item	Description
<b>Dial Mode</b> Tone Pulse	Specifies the dialing sound, either as a tone or a pulse.
<b>Max Speed</b> 2400 4800 9600 14400 33600	Specifies the maximum speed in baud at which faxes are sent
<b>Custom Job scanning</b> On Off	Lets you scan a document that contains mixed paper sizes into a single file
<b>Scan Preview</b> On Off	Specifies whether a preview will appear on the display for scan jobs
<b>Background Removal</b> -4 to +4	Adjusts the amount of background visible on a copy <b>Note:</b> 0 is the factory default setting.
<b>Auto Center</b> On Off	Lets you automatically center the fax on the page <b>Note:</b> Off is the factory default setting.
<b>Color Dropout</b> Color Dropout None Red Green Blue Default Red Threshold 0–255 Default Green Threshold 0–255 Default Blue Threshold 0–255	Specifies which color to drop during faxing, and how much to increase or decrease the dropout <b>Notes:</b> <ul style="list-style-type: none"> <li>• None is the factory default setting for Color Dropout.</li> <li>• 128 is the factory default setting for each color threshold.</li> </ul>
<b>Contrast</b> Best for content 0–5	Specifies the contrast of the output <b>Note:</b> “Best for content” is the factory default setting.
<b>Mirror Image</b> On Off	Creates a mirror image of the original document <b>Note:</b> Off is the factory default setting.
<b>Negative Image</b> On Off	Creates a negative image of the original document <b>Note:</b> Off is the factory default setting.

Menu item	Description
<b>Shadow Detail</b> 0–4	Adjusts the amount of shadow detail visible on a fax <b>Note:</b> 0 is the factory default setting.
<b>Scan edge to edge</b> On Off	Specifies if the original document is scanned edge-to-edge prior to faxing <b>Note:</b> Off is the factory default setting.
<b>Sharpness</b> 0–5	Adjusts the amount of sharpness on a fax <b>Note:</b> 3 is the factory default setting.
<b>Enable Color Fax Scans</b> On by default Never use Always use Off by default	Enables color faxing <b>Note:</b> “Off by default” is the factory default setting.
<b>Auto Convert Color Faxes to Mono Faxes</b> On Off	Converts all outgoing faxes to black and white <b>Note:</b> On is the factory default setting.

## Fax Receive Settings

Menu item	Description
<b>Enable Fax Receive</b> On Off	Allows fax jobs to be received by the printer <b>Note:</b> On is the factory default setting.
<b>Rings to Answer</b> 1–25	Specifies the number of rings before answering an incoming fax job <b>Note:</b> 1 is the factory default setting.
<b>Auto Reduction</b> On Off	Scales an incoming fax job so it fits the size of the paper loaded in the designated fax source <b>Note:</b> On is the factory default setting.
<b>Paper Source</b> Auto Tray <x> Multi-Purpose Feeder	Specifies the paper source selected to supply paper for the printer to print an incoming fax
<b>Output Bin</b> Standard Bin Bin 1 <x>	Specifies an output bin for received faxes <b>Note:</b> Bin 1 is available only when the finisher is installed.
<b>Sides (Duplex)</b> On Off	Enables duplex printing (two-sided printing) for incoming fax jobs
<b>Fax Footer</b> On Off	Prints the transmission information at the bottom of each page from a received fax <b>Note:</b> On is the factory default setting.

Menu item	Description
<b>Max Speed</b> 2400 4800 9600 14400 33600	Specifies the maximum speed in baud at which faxes are received
<b>Fax Forwarding</b> Forward Print Print and Forward	Enables forwarding of received faxes to another recipient
<b>Forward to</b> Fax E-mail FTP LDSS eSF	Specifies the type of recipient to which faxes will be forwarded <b>Note:</b> This item is available only from the printer Embedded Web Server.
<b>Forward to Shortcut</b>	Lets you enter the shortcut number which matches the recipient type (Fax, E-mail, FPT, LDSS, or eSF)
<b>Block No Name Fax</b> On Off	Enables blocking of incoming faxes sent from devices with no station ID specified
<b>Banned Fax List</b>	Enables the list of banned fax numbers stored in the printer
<b>Holding Faxes</b> Held Fax Mode Off Always On Manual Scheduled Fax Holding Schedule	Enables fax holding all of the time or according to a set schedule <b>Note:</b> Off is the factory default setting.
<b>Staple</b> On Off	Specifies the default staple setting for the attached finisher <b>Note:</b> Only the settings associated with the installed finisher appear.

## Fax Log Settings

Menu item	Description
<b>Transmission Log</b> Print log Do not print log Print only for error	Enables printing of a transmission log after each fax job
<b>Receive Error Log</b> Print Never Print on Error	Enables printing of a receive error log following a receive error



Menu item	Description
<b>Auto Print Logs</b> On Off	Enables automatic printing of fax logs <b>Note:</b> Logs print after every 200 jobs.
<b>Log Paper Source</b> Tray <x> Manual Feeder	Selects the source of the paper used for printing logs
<b>Logs Display</b> Remote Station Name Dialed Number	Specifies whether printed logs display the dialed number or the station name returned
<b>Enable Job Log</b> On Off	Enables access to the Fax Job log
<b>Enable Call Log</b> On Off	Enables access to the Fax Call log
<b>Log Output Bin</b> Standard Bin Bin <x>	Specifies the output bin where fax logs are printed

## Speaker Settings

Menu item	Description
<b>Speaker Mode</b> Always Off On until Connected Always On	<b>Notes:</b> <ul style="list-style-type: none"> <li>Always Off turns the speaker off.</li> <li>On until Connected is the factory default setting. The speaker is on and issues a noise until the fax connection is made.</li> <li>Always On turns the speaker on.</li> </ul>
<b>Speaker Volume</b> High Low	Controls the volume setting <b>Note:</b> High is the factory default setting.
<b>Ringer Volume</b> On Off	Controls the fax speaker ringer volume <b>Note:</b> On is the factory default setting.

## Distinctive Rings

Menu item	Description
<b>Single Ring</b> On Off	Answers calls with a one-ring pattern <b>Note:</b> On is the factory default setting.

Menu item	Description
<b>Double Ring</b> On Off	Answers calls with a double-ring pattern <b>Note:</b> On is the factory default setting.
<b>Triple Ring</b> On Off	Answers calls with a triple-ring pattern <b>Note:</b> On is the factory default setting.

## Fax Mode (Fax Server Setup) menu

Fax Server mode sends the fax job to a fax server for transmission.

### Fax Server Setup

Menu item	Description
<b>To Format</b> <b>Reply Address</b> <b>Subject</b> <b>Message</b>	Lets you enter the information using the virtual keyboard on the printer touch screen
<b>Primary SMTP Gateway</b>	Specifies SMTP server port information <b>Note:</b> 25 is the default SMTP gateway port.
<b>Secondary SMTP Gateway</b>	Specifies SMTP server port information <b>Note:</b> 25 is the default SMTP gateway port.
<b>Image Format</b> PDF (.pdf) XPS (.xps) TIFF (.tif)	Specifies the image type for scan to fax
<b>Content</b> Text Text/Photo Photograph	Specifies the type of content that will be scanned to fax <b>Notes:</b> <ul style="list-style-type: none"> <li>• Text is used when the document is mostly text.</li> <li>• Text/Photo is the factory default setting. Text/Photo is used when the documents are mostly text or line art.</li> <li>• Photograph is used when the document is a high-quality photograph or inkjet print.</li> </ul>
<b>Fax Resolution</b> Standard Fine Super Fine Ultra Fine	Specifies the resolution level for scan to fax
<b>Darkness</b> 1–9	Lightens or darkens the output <b>Note:</b> 5 factory default setting.

Menu item	Description
<b>Orientation</b> Portrait Landscape	Specifies the orientation of the scanned image
<b>Original Size</b> Letter Legal Executive Folio Statement Universal 4 x 6 in. 3 x 5 in. Business Card Custom Scan Size <x> A4 A5 Oficio (Mexico) A6 JIS B5 Book Original Auto Size Sense Mixed Letter/Legal	Specifies the paper size of the document that is being scanned <b>Note:</b> Letter is the US factory default setting. A4 is the international factory default setting.
<b>Use Multi-Page TIFF</b> On Off	Provides a choice between single-page TIFF files and multiple-page TIFF files. For a multiple-page scan to fax job, either one TIFF file is created containing all the pages, or multiple TIFF files are created with one file for each page of the job. <b>Notes:</b> <ul style="list-style-type: none"> <li>• On is the factory default setting.</li> <li>• This menu item applies to all scan functions.</li> </ul>
<b>Enable Analog Receive</b> On Off	Enables analog fax receive <b>Note:</b> Off is the factory default setting.

## E-mail Settings menu

Menu item	Description
<b>E-mail Server Setup</b> Subject Message	Specifies e-mail server information <b>Note:</b> The message box has a limitation of 512 characters.

Menu item	Description
<b>E-mail Server Setup</b> Send me a copy Never appears On by default Off by default Always On	Sends a copy of the e-mail back to the creator of the e-mail
<b>E-mail Server Setup</b> Max e-mail size 0–65535 KB	Specifies the maximum e-mail size in kilobytes <b>Note:</b> E-mail above the specified size is not sent.
<b>E-mail Server Setup</b> Size Error Message	Sends a message when an e-mail is greater than the configured size limit
<b>E-mail Server Setup</b> Limit destinations	Sends an e-mail only when the address contains the domain name, such as a company domain name <b>Notes:</b> <ul style="list-style-type: none"> <li>• E-mail can only be sent to the specified domain.</li> <li>• The limit is one domain.</li> </ul>
<b>E-mail Server Setup</b> Web Link Setup Server Login Password Path Base file name Web Link	Defines the path name <b>Note:</b> Defines the path. For example: /directory/path The following characters or symbols are invalid entries for a path name: * : ? < >   .
<b>Format</b> PDF (.pdf) Secure PDF TIFF (.tif) JPEG (.jpg) XPS (.xps)	Specifies the format of the file
<b>PDF Version</b> 1.2–1.6	Sets the version of the PDF file that will be scanned to e-mail <b>Note:</b> 1.5 is the factory default setting.
<b>Content</b> Text/Photo Photograph Text	Specifies the type of content that will be scanned to e-mail <b>Notes:</b> <ul style="list-style-type: none"> <li>• Text/Photo is the factory default setting. Text/Photo is used when the documents are mostly text or line art.</li> <li>• Photograph is used when the document is a high-quality photograph or inkjet print.</li> <li>• Text is used when the document is mostly text.</li> </ul>

Menu item	Description
<b>Color</b> Gray Color	Specifies whether a job prints in grayscale or color <b>Note:</b> Gray is the factory default setting.
<b>Resolution</b> 75 150 200 300 400 600	Specifies how many dots per inch are scanned <b>Note:</b> 150 dpi is the factory default setting.
<b>Darkness</b> 1–9	Lightens or darkens the output <b>Note:</b> 5 is the factory default setting.
<b>Orientation</b> Portrait Landscape	Specifies the orientation of the scanned image <b>Note:</b> Portrait is the factory default setting.
<b>Original Size</b> Letter Legal Executive Folio Statement Universal 4 x 6 in. 3 x 5 in. Business Card Custom Scan Size <x> A4 A5 Oficio (Mexico) A6 JIS B5 Book Original Auto Size Sense Mixed Letter/Legal	Specifies the paper size of the document that is being scanned <b>Note:</b> Letter is the US factory default setting. A4 is the international factory default setting.
<b>Sides (Duplex)</b> Off Long edge Short edge	Specifies how the text and graphics are oriented on the page <b>Notes:</b> <ul style="list-style-type: none"> <li>• Off is the factory default setting.</li> <li>• Long edge assumes binding along the long edge of the page (left edge for portrait orientation and top edge for landscape orientation).</li> <li>• Short edge assumes binding along the short edge of the page (top edge for portrait orientation and left edge for landscape orientation).</li> </ul>

Menu item	Description
<b>JPEG Quality</b> Best for content 5–90	Sets the quality of a JPEG photo image in relation to file size and the quality of the image <b>Notes:</b> <ul style="list-style-type: none"> <li>• “Best for content” is the factory default setting.</li> <li>• 5 reduces the file size, but the quality of the image is lessened.</li> <li>• 90 provides the best image quality, but the file size is very large.</li> <li>• This menu item applies to all scan functions.</li> </ul>
<b>E-mail images sent as</b> Attachment Web Link	Specifies how the images will be sent <b>Note:</b> Attachment is the factory default setting.
<b>Use Multi-Page TIFF</b> On Off	Provides a choice between single-page TIFF files and multiple-page TIFF files. For a multiple-page scan to e-mail job, either one TIFF file is created containing all the pages, or multiple TIFF files are created with one file for each page of the job. <b>Notes:</b> <ul style="list-style-type: none"> <li>• On is the factory default setting.</li> <li>• This menu item applies to all scan functions.</li> </ul>
<b>Transmission Log</b> Print log Do not print log Print only for error	Specifies whether the transmission log prints <b>Note:</b> “Print log” is the factory default setting.
<b>Log Paper Source</b> Tray <x> Manual Feeder Manual Env MP Feeder	Specifies a paper source for printing e-mail logs <b>Note:</b> Tray 1 is the factory default setting.
<b>Log Output Bin</b> Standard Bin Bin <x>	Specifies an output bin for the printed e-mail log
<b>E-mail Bit Depth</b> 8 bit 1 bit	Enables the Text/Photo mode to have smaller file sizes by using 1-bit images when Color is set to Off. <b>Note:</b> 8 bit is the factory default setting.
<b>Custom Job scanning</b> On Off	Lets you copy a document that contains mixed paper sizes into a single job
<b>Scan Preview</b> On Off	Specifies whether a preview will appear on the display for scan jobs <b>Note:</b> Off is the factory default setting.

Menu item	Description
<b>Allow Save as Shortcut</b> On Off	Lets you save e-mail addresses as shortcuts <b>Notes:</b> <ul style="list-style-type: none"> <li>Off is the factory default setting.</li> <li>When set to Off, the Save as Shortcut button does not appear on the E-mail Destination screen.</li> </ul>
<b>Background Removal</b> -4 to +4	Adjusts the amount of background visible on a scanned image <b>Note:</b> 0 is the factory default setting.
<b>Auto Center</b> On Off	Lets you automatically center the copy on the page <b>Note:</b> Off is the factory default setting.
<b>Color Dropout</b> Color Dropout None Red Green Blue Default Red Threshold 0–255 Default Green Threshold 0–255 Default Blue Threshold 0–255	Specifies which color to drop during scanning, and how much to increase or decrease the dropout <b>Notes:</b> <ul style="list-style-type: none"> <li>None is the factory default setting for Color Dropout.</li> <li>128 is the factory default setting for each color threshold.</li> </ul>
<b>Contrast</b> 0–5 Best for content	Specifies the contrast of the output <b>Note:</b> “Best for content” is the factory default setting.
<b>Mirror Image</b> On Off	Creates a mirror image of the original document <b>Note:</b> Off is the factory default setting.
<b>Negative Image</b> On Off	Creates a negative image of the original document <b>Note:</b> Off is the factory default setting.
<b>Shadow Detail</b> 0–4	Adjusts the amount of shadow detail visible on a scanned image <b>Note:</b> 0 is the factory default setting.
<b>Scan edge to edge</b> On Off	Specifies whether the original document is scanned edge-to-edge <b>Note:</b> Off is the factory default setting.
<b>Sharpness</b> 0–5	Adjusts the amount of sharpness on a scanned image <b>Note:</b> 3 is the factory default setting.
<b>Use cc:/bcc:</b> On Off	Enables the use of the cc: and bcc: fields <b>Note:</b> Off is the factory default setting.

## FTP Settings menu

Menu item	Description
<b>Format</b> PDF (.pdf) Secure PDF TIFF (.tif) JPEG (.jpg) XPS (.xps)	Specifies the format of the FTP file <b>Note:</b> PDF (.pdf) is the factory default setting.
<b>PDF Version</b> 1.2–1.6	Sets the version level of the PDF file for FTP <b>Note:</b> 1.5 is the factory default setting.
<b>Content</b> Text/Photo Photograph Text	Specifies the type of content that will be scanned to FTP <b>Notes:</b> <ul style="list-style-type: none"> <li>• Text/Photo is the factory default setting. Text/Photo is used when the documents are mostly text or line art.</li> <li>• Photograph is used when the document is a high-quality photograph or inkjet print</li> <li>• Text is used when the document is mostly text.</li> </ul>
<b>Color</b> Gray Color	Specifies whether a job prints in grayscale or color <b>Note:</b> Gray is the factory default setting.
<b>Resolution</b> 75 150 200 300 400 600	Specifies how many dots per inch are scanned <b>Note:</b> 150 dpi is the factory default setting.
<b>Darkness</b> 1–9	Lightens or darkens the output <b>Note:</b> 5 is the factory default setting.
<b>Orientation</b> Portrait Landscape	Specifies the orientation of the scanned image <b>Note:</b> Portrait is the factory default setting.



Menu item	Description
<p><b>Original Size</b></p> <p>Letter  Legal  Executive  Folio  Statement  Universal  4 x 6 in.  3 x 5 in.  Business Card  Custom Scan Size &lt;x&gt;  A4  A5  Oficio (Mexico)  A6  JIS B5  Book Original  Auto Size Sense  Mixed Letter/Legal</p>	<p>Specifies the paper size of the document that is being scanned</p> <p><b>Note:</b> Letter is the US factory default setting. A4 is the international factory default setting.</p>
<p><b>Sides (Duplex)</b></p> <p>Off  Long edge  Short edge</p>	<p>Specifies how the text and graphics are oriented on the page</p> <p><b>Notes:</b></p> <ul style="list-style-type: none"> <li>• Off is the factory default setting.</li> <li>• Long edge assumes binding along the long edge of the page (left edge for portrait orientation and top edge for landscape orientation).</li> <li>• Short edge assumes binding along the short edge of the page (top edge for portrait orientation and left edge for landscape orientation).</li> </ul>
<p><b>JPEG Quality</b></p> <p>Best for content  5–90</p>	<p>Sets the quality of a JPEG photo image in relation to file size and the quality of the image</p> <p><b>Notes:</b></p> <ul style="list-style-type: none"> <li>• “Best for content” is the factory default setting.</li> <li>• 5 reduces the file size, but the quality of the image is lessened.</li> <li>• 90 provides the best image quality, but the file size is very large.</li> <li>• This menu item applies to all scan functions.</li> </ul>
<p><b>Use Multi-Page TIFF</b></p> <p>On  Off</p>	<p>Provides a choice between single-page TIFF files and multiple-page TIFF files. For a multiple-page scan to FTP job, either one TIFF file is created containing all the pages, or multiple TIFF files are created with one file for each page of the job.</p> <p><b>Notes:</b></p> <ul style="list-style-type: none"> <li>• On is the factory default setting.</li> <li>• This menu item applies to all scan functions.</li> </ul>

Menu item	Description
<b>Transmission Log</b> Print log Do not print log Print only for error	Specifies whether the transmission log prints <b>Note:</b> "Print log" is the factory default setting.
<b>Log Paper Source</b> Tray <x> Manual Feeder Manual Env MP Feeder	Specifies a paper source for FTP logs <b>Note:</b> Tray 1 is the factory default setting.
<b>Log Output Bin</b> Standard Bin Bin <x>	Specifies an output bin for the FTP log
<b>FTP bit Depth</b> 8 bit 1 bit	Enables the Text/Photo mode to have smaller file sizes by using 1-bit images when Color is set to Off <b>Note:</b> 8 bit is the factory default setting.
<b>Base File Name</b>	Lets you enter a base file name
<b>Custom Job Scanning</b> On Off	Lets you copy a document that contains mixed paper sizes into a single job
<b>Scan Preview</b> On Off	Specifies whether a preview will appear on the display for scan jobs <b>Note:</b> Off is the factory default setting.
<b>Allow Save as Shortcut</b> On Off	Enables shortcut creation for FTP addresses <b>Note:</b> On is the factory default setting.
<b>Background Removal</b> -4 to +4	Adjusts the amount of background visible on a copy <b>Note:</b> 0 is the factory default setting.
<b>Auto Center</b> On Off	Lets you automatically center the copy on the page <b>Note:</b> Off is the factory default setting.
<b>Color Dropout</b> Color Dropout None Red Green Blue Default Red Threshold 0–255 Default Green Threshold 0–255 Default Blue Threshold 0–255	Specifies which color to drop during scanning, and how much to increase or decrease the dropout <b>Notes:</b> <ul style="list-style-type: none"> <li>• None is the factory default setting for Color Dropout.</li> <li>• 128 is the factory default setting for each color threshold.</li> </ul>

Menu item	Description
<b>Contrast</b> 0–5 Best for content	Specifies the contrast of the output <b>Note:</b> “Best for content” is the factory default setting.
<b>Mirror Image</b> On Off	Creates a mirror image of the original document <b>Note:</b> Off is the factory default setting.
<b>Negative Image</b> On Off	Creates a negative image of the original document <b>Note:</b> Off is the factory default setting.
<b>Shadow Detail</b> 0–4	Adjusts the amount of shadow detail visible on a scanned image <b>Note:</b> 0 is the factory default setting.
<b>Scan edge to edge</b> On Off	Specifies whether the original document is scanned edge-to-edge <b>Note:</b> Off is the factory default setting.
<b>Sharpness</b> 0–5	Adjusts the amount of sharpness on a scanned image <b>Note:</b> 3 is the factory default setting.

## Flash Drive menu

### Scan Settings

Menu item	Description
<b>Format</b> PDF (.pdf) Secure PDF TIFF (.tif) JPEG (.jpg) XPS (.xps)	Specifies the format of the file
<b>PDF Version</b> 1.2–1.6	Sets the version of the PDF file that will be scanned to USB <b>Note:</b> 1.5 is the factory default setting.
<b>Content</b> Text/Photo Photograph Text	Specifies the type of content that will be scanned to USB <b>Notes:</b> <ul style="list-style-type: none"> <li>• Text/Photo is the factory default setting. Text/Photo is used when the documents are mostly text or line art.</li> <li>• Photograph is used when the document is a high-quality photograph or inkjet print</li> <li>• Text is used when the document is mostly text.</li> </ul>
<b>Color</b> Gray Color	Specifies whether job prints in grayscale or color <b>Note:</b> Gray is the factory default setting.

Menu item	Description
<b>Resolution</b> 75 150 200 300 400 600	Specifies how many dots per inch are scanned <b>Note:</b> 150 dpi is the factory default setting.
<b>Darkness</b> 1–9	Lightens or darkens the output <b>Note:</b> 5 is the factory default setting.
<b>Orientation</b> Portrait Landscape	Specifies the orientation of the scanned image <b>Note:</b> Portrait is the factory default setting.
<b>Original Size</b> Letter Legal Executive Folio Statement Universal 4 x 6 in. 3 x 5 in. Business Card Custom Scan Size <x> A4 A5 Oficio (Mexico) A6 JIS B5 Book Original Auto Size Sense Mixed Letter/Legal	Specifies the paper size of the document that is being scanned <b>Note:</b> Letter is the US factory default setting. A4 is the international factory default setting.
<b>Sides (Duplex)</b> Off Long edge Short edge	Specifies how the text and graphics are oriented on the page <b>Notes:</b> <ul style="list-style-type: none"> <li>• Off is the factory default setting.</li> <li>• Long edge assumes binding along the long edge of the page (left edge for portrait orientation and top edge for landscape orientation).</li> <li>• Short edge assumes binding along the short edge of the page (top edge for portrait orientation and left edge for landscape orientation).</li> </ul>

Menu item	Description
<b>Photo JPEG Quality</b> 5–90	Sets the quality of a JPEG photo image in relation to file size and the quality of the image <b>Notes:</b> <ul style="list-style-type: none"> <li>• 50 is the factory default setting.</li> <li>• 5 reduces the file size, but the quality of the image is lessened.</li> <li>• 90 provides the best image quality, but the file size is very large.</li> <li>• This menu item applies to all scan functions.</li> </ul>
<b>JPEG Quality</b> Best for content 5–90	Sets the quality of a JPEG text or text/photo image in relation to file size and the quality of the image. <b>Notes:</b> <ul style="list-style-type: none"> <li>• “Best for content” is the factory default setting.</li> <li>• 5 reduces the file size, but the quality of the image is lessened.</li> <li>• 90 provides the best image quality, but the file size is very large.</li> <li>• This menu item applies to Text, Text/Photo, and all scan functions.</li> </ul>
<b>Use Multi-Page TIFF</b> On Off	Provides a choice between single-page TIFF files and multiple-page TIFF files. For a multiple-page scan to USB job, either one TIFF file is created containing all the pages, or multiple TIFF files are created with one file for each page of the job. <b>Notes:</b> <ul style="list-style-type: none"> <li>• On is the factory default setting.</li> <li>• This menu item applies to all scan functions.</li> </ul>
<b>Scan bit Depth</b> 8 bit 1 bit	Enables the Text/Photo mode to have smaller file sizes by using 1-bit images when Color is set to Off <b>Note:</b> 8 bit is the factory default setting.
<b>Base File Name</b>	Lets you enter a base file name
<b>Custom Job scanning</b> Off On	Lets you copy a document that contains mixed paper sizes into a single job
<b>Scan Preview</b> On Off	Specifies whether a preview will appear on the display for scan jobs <b>Note:</b> Off is the factory default setting.
<b>Background Removal</b> -4 to +4	Adjusts the amount of background visible on a copy <b>Note:</b> 0 is the factory default setting.
<b>Auto Center</b> On Off	Lets you automatically center the copy on the page <b>Note:</b> Off is the factory default setting.

Menu item	Description
<b>Color Dropout</b> Color Dropout None Red Green Blue Default Red Threshold 0–255 Default Green Threshold 0–255 Default Blue Threshold 0–255	Specifies which color to drop during scanning, and how much to increase or decrease the dropout <b>Notes:</b> <ul style="list-style-type: none"> <li>• None is the factory default setting for Color Dropout.</li> <li>• 128 is the factory default setting for each color threshold.</li> </ul>
<b>Contrast</b> 0–5 Best for content	Specifies the contrast of the output <b>Note:</b> “Best for content” is the factory default setting.
<b>Mirror Image</b> On Off	Creates a mirror image of the original document <b>Note:</b> Off is the factory default setting.
<b>Negative Image</b> On Off	Creates a negative image of the original document <b>Note:</b> Off is the factory default setting.
<b>Shadow Detail</b> 0–4	Adjusts the amount of shadow detail visible on a scanned image <b>Note:</b> 0 is the factory default setting.
<b>Scan edge to edge</b> On Off	Specifies whether the original document is scanned edge-to-edge <b>Note:</b> Off is the factory default setting.
<b>Sharpness</b> 0–5	Adjusts the amount of sharpness on a scanned image <b>Note:</b> 3 is the factory default setting.

## Print Settings

Menu item	Description
<b>Copies</b>	Specifies the number of copies to print
<b>Paper Source</b> Tray <x> MP Feeder Manual Paper Manual Envelope	Specifies the paper source selected to supply paper for the printer to print from the flash drive
<b>Collate</b> Off (1,1,1,2,2,2) On (1,2,1,2,1,2)	Stacks the pages of a print job in sequence when printing multiple copies <b>Notes:</b> <ul style="list-style-type: none"> <li>• Off is the factory default setting. No pages will be collated.</li> <li>• The On setting stacks the print job sequentially.</li> </ul>

Menu item	Description
<b>Sides (Duplex)</b> On Off	Enables duplex printing (two-sided printing)
<b>Staple</b> On Off	Enables stapling <b>Note:</b> Off is the factory default setting.
<b>Duplex Binding</b> Long Edge Short Edge	Defines the way duplexed pages are bound and how the printing on the back of the page is oriented in relation to the printing on the front of the page <b>Notes:</b> <ul style="list-style-type: none"> <li>• Long Edge is the factory default setting.</li> <li>• Long Edge specifies that binding be placed on the left edge of portrait pages and the top edge of landscape pages.</li> <li>• Short Edge specifies that binding be placed on the top edge of portrait pages and the left edge of landscape pages.</li> </ul>
<b>Orientation</b> Auto Portrait Landscape	Specifies the orientation of the print job <b>Note:</b> Auto is the factory default setting.
<b>N-up (pages/side)</b> Off 2 Up 3 Up 4 Up 6 Up 9 Up 12 Up 16 Up	Specifies that multiple-page images be printed on one side of a sheet of paper. This is also referred to as Paper Saver. <b>Notes:</b> <ul style="list-style-type: none"> <li>• Off is the factory default setting.</li> <li>• The number selected is the number of page images that will print per side.</li> </ul>
<b>N-up Border</b> None Solid	Prints a border around each page image when using N-up <b>Note:</b> None is the factory default setting.
<b>N-up Ordering</b> Horizontal Reverse Horizontal Reverse Vertical Vertical	Specifies the positioning of multiple-page images when using N-up <b>Notes:</b> <ul style="list-style-type: none"> <li>• Horizontal is the factory default setting.</li> <li>• Positioning depends on the number of images and whether the images are in portrait or landscape orientation.</li> </ul>
<b>Separator Sheets</b> None Between Copies Between Jobs Between Pages	Places a sheet of paper between pages, copies, or jobs based on the value selected <b>Note:</b> None is the factory default setting.

Menu item	Description
<b>Separator Source</b> Tray <x> Manual Feeder Envelope Feeder	Specifies a paper source
<b>Blank Pages</b> Do Not Print Print	Specifies whether blank pages are inserted in a print job <b>Note:</b> Do Not Print is the factory default setting.

## Print Settings

### Setup menu

Menu item	Description
<b>Printer Language</b> PCL Emulation PS Emulation	Sets the default printer language <b>Notes:</b> <ul style="list-style-type: none"> <li>• PCL emulation uses a PCL interpreter for processing print jobs. PostScript emulation uses a PS interpreter for processing print jobs.</li> <li>• PCL is the factory default printer language.</li> <li>• Setting a printer language as the default does not prevent a software program from sending print jobs that use another printer language.</li> </ul>
<b>Job Waiting</b> On Off	Specifies that print jobs be removed from the print queue if they require unavailable printer options or custom settings. They are stored in a separate print queue, so other jobs print normally. When the missing information and/or options are obtained, the stored jobs print. <b>Notes:</b> <ul style="list-style-type: none"> <li>• Off is the factory default setting.</li> <li>• This menu appears only if a non-Read Only printer hard disk is installed. This requirement ensures that stored jobs are not deleted if the printer loses power.</li> </ul>



Menu item	Description
<p><b>Print Area</b></p> <ul style="list-style-type: none"> <li>Normal</li> <li>Whole Page</li> </ul>	<p>Sets the logical and physical printable area</p> <p><b>Notes:</b></p> <ul style="list-style-type: none"> <li>• This menu does not appear if Edge to Edge is enabled in the printer Setup menu.</li> <li>• Normal is the factory default setting. When attempting to print data in the non-printable area defined by the Normal setting, the printer clips the image at the boundary.</li> <li>• The Whole Page setting allows the image to be moved into the non-printable area defined by the Normal setting, but the printer will clip the image at the Normal setting boundary.</li> <li>• The Whole Page setting only affects pages printed using a PCL 5e interpreter. This setting has no effect on pages printed using the PCL XL or PostScript interpreter.</li> </ul>
<p><b>Download Target</b></p> <ul style="list-style-type: none"> <li>RAM</li> <li>Flash</li> <li>Disk</li> </ul>	<p>Sets the storage location for downloads</p> <p><b>Notes:</b></p> <ul style="list-style-type: none"> <li>• RAM is the factory default setting.</li> <li>• Storing downloads in flash memory or on a printer hard disk places them in permanent storage. Downloads remain in flash memory or on the printer hard disk even when the printer is turned off.</li> <li>• Storing downloads in RAM is temporary.</li> <li>• This menu appears only if a flash and/or disk option is installed.</li> </ul>
<p><b>Job Accounting</b></p> <ul style="list-style-type: none"> <li>On</li> <li>Off</li> </ul>	<p>Specifies whether the printer stores statistical information about the most recent print jobs on the hard disk</p> <p><b>Notes:</b></p> <ul style="list-style-type: none"> <li>• Off is the factory default setting. Off means the printer does not store job statistics.</li> <li>• The statistics include a record of print errors, the print time, the job size in bytes, the requested paper size and type, the total number of printed pages, and the total number of copies requested.</li> <li>• Job Accounting is available only when a printer hard disk is installed and working properly. It should not be Read/Write or Write protected. Job Buffer Size should not be set to 100%.</li> <li>• Changing this setting from the printer control panel and then exiting the menus causes the printer to reset. The menu selection is updated.</li> </ul>

Menu item	Description
<b>Resource Save</b> On Off	Specifies how the printer handles temporary downloads, such as fonts and macros stored in RAM, when the printer receives a job that requires more memory than is available  <b>Notes:</b> <ul style="list-style-type: none"> <li>Off is the factory default setting. Off sets the printer to retain the downloads only until memory is needed. Downloads are deleted in order to process print jobs.</li> <li>The On setting retains the downloads during language changes and printer resets. If the printer runs out of memory, <b>38 Memory Full</b> appears, and downloads are not deleted.</li> </ul>
<b>Print All Order</b> Alphabetically Newest First Oldest First	Specifies the order in which held and confidential jobs are printed when Print All is selected  <b>Notes:</b> <ul style="list-style-type: none"> <li>Alphabetically is the factory default setting.</li> <li>Print jobs always appear in alphabetical order on the printer control panel.</li> </ul>

## Finishing menu

Menu item	Description
<b>Sides (Duplex)</b> 2 sided 1 sided	Specifies whether duplex (2-sided) printing is set as the default for all print jobs  <b>Notes:</b> <ul style="list-style-type: none"> <li>1 sided is the factory default setting.</li> <li>To set 2-sided printing from the software program: for Windows users, click <b>File → Print</b>, and then click <b>Properties, Preferences, Options, or Setup</b>; for Macintosh users, choose <b>File &gt; Print</b>, and then adjust the settings from the Print dialog and pop-up menus.</li> </ul>
<b>Duplex Binding</b> Long Edge Short Edge	Defines the way duplexed pages are bound and how the printing on the back of the page is oriented in relation to the printing on the front of the page  <b>Notes:</b> <ul style="list-style-type: none"> <li>Long Edge is the factory default setting.</li> <li>Long Edge specifies that binding be placed on the left edge of portrait pages and the top edge of landscape pages.</li> <li>Short Edge specifies that binding be placed on the top edge of portrait pages and the left edge of landscape pages.</li> </ul>
<b>Copies</b> 1–999	Specifies a default number of copies for each print job  <b>Note:</b> 1 is the factory default setting.
<b>Blank Pages</b> Do Not Print Print	Specifies whether blank pages are inserted in a print job  <b>Note:</b> Do Not Print is the factory default setting.

Menu item	Description
<b>Collate</b> Off (1,1,1,2,2,2) On (1,2,1,2,1,2)	Stacks the pages of a print job in sequence when printing multiple copies <b>Notes:</b> <ul style="list-style-type: none"> <li>• Off is the factory default setting. No pages will be collated.</li> <li>• The On setting stacks the print job sequentially.</li> <li>• Both settings print the entire job the number of times specified by the Copies menu setting.</li> </ul>
<b>Separator Sheets</b> None Between Copies Between Jobs Between Pages	Specifies whether blank separator sheets are inserted <b>Notes:</b> <ul style="list-style-type: none"> <li>• None is the factory default setting.</li> <li>• Between Copies inserts a blank sheet between each copy of a print job if Collation is set to On. If Collation is set to Off, a blank page is inserted between each set of printed pages, such as after all page 1's and after all page 2's.</li> <li>• Between Jobs inserts a blank sheet between print jobs.</li> <li>• Between Pages inserts a blank sheet between each page of the print job. This setting is useful when printing transparencies or inserting blank pages in a document for notes.</li> </ul>
<b>Separator Source</b> Tray <x> Multi-Purpose Feeder Envelope Feeder	Specifies the paper source for separator sheets <b>Notes:</b> <ul style="list-style-type: none"> <li>• Tray 1 (standard tray) is the factory default setting.</li> <li>• From the Paper menu, Configure MP must be set to Cassette in order for Multi-Purpose Feeder to appear as a menu setting.</li> </ul>
<b>N-up (pages-side)</b> Off 2-Up 3-Up 4-Up 6-Up 9-Up 12-Up 16-Up	Specifies that multiple-page images be printed on one side of a sheet of paper <b>Notes:</b> <ul style="list-style-type: none"> <li>• Off is the factory default setting.</li> <li>• The number selected is the number of page images that will print per side.</li> </ul>
<b>N-up Ordering</b> Horizontal Reverse Horizontal Reverse Vertical Vertical	Specifies the positioning of multiple-page images when using N-up (pages-sides) <b>Notes:</b> <ul style="list-style-type: none"> <li>• Horizontal is the factory default setting.</li> <li>• Positioning depends on the number of images and whether the images are in portrait or landscape orientation.</li> </ul>
<b>Orientation</b> Auto Landscape Portrait	Specifies the orientation of a multiple-page sheet <b>Note:</b> Auto is the factory default setting. The printer chooses between portrait and landscape.

Menu item	Description
<b>N-up Border</b> None Solid	Prints a border around each page image when using N-up (pages-sides) <b>Note:</b> None is the factory default setting.
<b>Staple Job</b> Off On	Specifies whether print jobs are stapled <b>Notes:</b> <ul style="list-style-type: none"> <li>• This menu item is available only when the StapleSmart Finisher is installed.</li> <li>• Off is the factory default setting. Print jobs are not stapled.</li> <li>• Envelopes are not stapled.</li> </ul>
<b>Offset Pages</b> Off Between Jobs Between Copies	Stacks copies or print jobs into staggered sets in an output bin <b>Notes:</b> <ul style="list-style-type: none"> <li>• This menu item appears only when the StapleSmart Finisher is installed.</li> <li>• Off is the factory default setting. No pages are offset during the print job.</li> <li>• Between Jobs offsets each print job.</li> <li>• Between Copies offsets each copy of a print job.</li> </ul>

## Quality menu

Menu item	Description
<b>Print Resolution</b> 300 dpi 600 dpi 1200 dpi 1200 Image Q 2400 Image Q	Specifies the printed output resolution <b>Note:</b> 600 dpi is the factory default setting. The printer driver default is 1200 IQ.
<b>Pixel Boost</b> Off Fonts Horizontally Vertically Both Directions	Enhances the printed quality of small fonts and graphics <b>Notes:</b> <ul style="list-style-type: none"> <li>• Off is the factory default setting.</li> <li>• Fonts applies this setting only to text.</li> <li>• Horizontally darkens horizontal lines of text and images.</li> <li>• Vertically darkens vertical lines of text and images.</li> <li>• Both Directions darkens horizontal and vertical lines on text and images.</li> </ul>
<b>Toner Darkness</b> 1–10	Lightens or darkens the printed output <b>Notes:</b> <ul style="list-style-type: none"> <li>• 8 is the factory default setting.</li> <li>• Selecting a smaller number can help conserve toner.</li> </ul>

Menu item	Description
<b>Enhance Fine Lines</b> On Off	Enables a print mode preferable for files such as architectural drawings, maps, electrical circuit diagrams, and flow charts <b>Notes:</b> <ul style="list-style-type: none"> <li>• Off is the factory default setting.</li> <li>• To set Enhance Fine Lines using the Embedded Web Server, type the network printer IP address in a browser window.</li> </ul>
<b>Gray Correction</b> Auto Off	Adjusts the gray value of printed output <b>Note:</b> Auto is the factory default setting.
<b>Brightness</b> -6 to +6	Adjusts or darkens printed output and conserves toner <b>Notes:</b> <ul style="list-style-type: none"> <li>• 0 is the factory default setting.</li> <li>• A negative value will darken text, images, and graphics. A positive value will lighten them and conserve toner.</li> </ul>
<b>Contrast</b> 0-5	Adjusts the degree of difference between levels of gray in printed output <b>Notes:</b> <ul style="list-style-type: none"> <li>• 0 is the factory default setting.</li> <li>• Higher settings show more difference between levels of gray.</li> </ul>

## Utilities menu

Menu item	Description
<b>Remove Held Jobs</b> Confidential Held Not Restored All	Removes confidential and held jobs from the printer hard disk <b>Notes:</b> <ul style="list-style-type: none"> <li>• Selecting a setting affects only print jobs that are resident in the printer. Bookmarks, jobs on flash drives, and other types of held jobs are not affected.</li> <li>• Selecting Not Restored removes all Print and Hold jobs that were <i>not</i> restored from the disk.</li> </ul>
<b>Format Flash</b> Yes No	Formats the flash memory. Flash memory refers to the memory added by installing a flash memory option card in the printer. <b>Warning—Potential Damage:</b> Do not turn off the printer while the flash memory is formatting. <b>Notes:</b> <ul style="list-style-type: none"> <li>• A flash memory option card must be installed in the printer and operating properly for this menu item to be available. The flash memory option card must not be Read/Write or Write protected.</li> <li>• Selecting Yes deletes all data stored in flash memory.</li> <li>• No cancels the format request.</li> </ul>

Menu item	Description
<b>Delete Downloads on Disk</b> Delete Now Do Not Delete	Removes downloads from the printer hard disk, including all held Jobs, buffered jobs, and parked jobs. Job accounting information is not affected. <b>Note:</b> Delete Now is the default setting.
<b>Job Acct Stat</b> Print Clear	Prints a list of all stored job statistics or deletes the information from the printer hard disk <b>Notes:</b> <ul style="list-style-type: none"> <li>• A printer hard disk must be installed in the printer and operating properly for this menu item to be available.</li> <li>• Selecting Print prints a list of statistics.</li> <li>• Clear deletes all job statistics stored on the printer hard disk.</li> <li>• The Clear selection will not appear if Job Accounting is set to MarkTrack™ using NPA.</li> </ul>
<b>Hex Trace</b> Activate	Assists in isolating the source of a print job problem <b>Notes:</b> <ul style="list-style-type: none"> <li>• When Activate is selected, all data sent to the printer is printed in hexadecimal and character representation and control codes are not executed.</li> <li>• To exit or deactivate Hex Trace, turn the printer off or reset the printer.</li> </ul>
<b>Coverage Estimator</b> Off On	Provides an estimate of the percentage coverage of black on a page. The estimate is printed on a separate page at the end of each print job. <b>Note:</b> Off is the factory default setting.
<b>LCD Contrast</b> 1–10	Adjusts the contrast lighting of the display <b>Notes:</b> <ul style="list-style-type: none"> <li>• 5 is the factory default setting.</li> <li>• A higher setting makes the display appear lighter.</li> <li>• A lower setting makes the display appear darker.</li> </ul>
<b>LCD Brightness</b> 1–10	Adjusts the brightness of the backlight on the display <b>Notes:</b> <ul style="list-style-type: none"> <li>• 5 is the factory default setting.</li> <li>• A higher setting makes the display appear lighter.</li> <li>• A lower setting makes the display appear darker.</li> </ul>

## PDF menu

Menu item	Description
<b>Scale to Fit</b> Yes No	Scales page content to fit the selected paper size <b>Note:</b> No is the factory default setting.
<b>Annotations</b> Do Not Print Print	Prints annotations in a PDF <b>Note:</b> Do Not Print is the factory default setting.

## PostScript menu

Menu item	Description
<b>Print PS Error</b> On Off	Prints a page containing the PostScript error <b>Note:</b> Off is the factory default setting.
<b>Font Priority</b> Resident Flash/Disk	Establishes the font search order <b>Notes:</b> <ul style="list-style-type: none"> <li>• Resident is the factory default setting.</li> <li>• A formatted flash memory option card or printer hard disk must be installed in the printer and operating properly for this menu item to be available.</li> <li>• The flash memory option or printer hard disk cannot be Read/Write, Write, or password protected.</li> <li>• Job Buffer Size must not be set to 100%.</li> </ul>

## PCL Emul menu

Menu item	Description
<b>Font Source</b> Resident Disk Download Flash All	Specifies the set of fonts used by the Font Name menu item <b>Notes:</b> <ul style="list-style-type: none"> <li>• Resident is the factory default setting. It shows the factory default set of fonts downloaded into printer RAM.</li> <li>• Flash and Disk settings appear only if applicable and show all fonts resident in that option.</li> <li>• Flash and Disk options must be properly formatted and cannot be Read/Write, Write, or password protected.</li> <li>• Download appears only if applicable and shows all the fonts downloaded into printer RAM.</li> <li>• All shows all fonts available to any option.</li> </ul>
<b>Font Name</b> <list of available fonts>	Identifies a specific font and the option where it is stored <b>Notes:</b> <ul style="list-style-type: none"> <li>• Courier 10 is the factory default setting.</li> <li>• The font source abbreviation is R for Resident, F for Flash, K for Disk, and D for download.</li> </ul>
<b>Symbol Set</b> 10U PC-8 12U PC-850	Specifies the symbol set for each font name <b>Notes:</b> <ul style="list-style-type: none"> <li>• 10U PC-8 is the US factory default setting.</li> <li>• 12U PC-850 is the international factory default setting.</li> <li>• A symbol set is a set of alphabetic and numeric characters, punctuation, and special symbols. Symbol sets support the different languages or specific programs such as math symbols for scientific text. Only the supported symbol sets are shown.</li> </ul>

Menu item	Description
<b>PCL Emulation Settings</b> Pitch 0.08–100	Specifies the font pitch for scalable monospaced fonts <b>Notes:</b> <ul style="list-style-type: none"> <li>• 10 is the factory default setting.</li> <li>• Pitch refers to the number of fixed-space characters per inch (cpi).</li> <li>• Pitch can be increased or decreased in 0.01-cpi increments.</li> <li>• For nonscalable monospaced fonts, the pitch appears on the display but cannot be changed.</li> </ul>
<b>PCL Emulation Settings</b> Orientation Portrait Landscape	Specifies the orientation of text and graphics on the page <b>Notes:</b> <ul style="list-style-type: none"> <li>• Portrait is the factory default setting.</li> <li>• Portrait prints text and graphics parallel to the short edge of the page.</li> <li>• Landscape prints text and graphics parallel to the long edge of the page.</li> </ul>
<b>PCL Emulation Settings</b> Lines per Page 1–255	Specifies the number of lines that print on each page <b>Notes:</b> <ul style="list-style-type: none"> <li>• 60 is the US factory default setting. 64 is the international default setting.</li> <li>• The printer sets the amount of space between each line based on the Lines per Page, Paper Size, and Orientation settings. Select the desired Paper Size and Orientation <i>before</i> setting Lines per Page.</li> </ul>
<b>PCL Emulation Settings</b> A4 Width 198 mm 203 mm	Sets the printer to print on A4-size paper <b>Notes:</b> <ul style="list-style-type: none"> <li>• 198 mm is the factory default setting.</li> <li>• The 203-mm setting sets the width of the page to allow the printing of eighty 10-pitch characters.</li> </ul>
<b>PCL Emulation Settings</b> Auto CR after LF On Off	Specifies whether the printer automatically performs a carriage return after a line feed control command <b>Note:</b> Off is the factory default setting.
<b>PCL Emulation Settings</b> Auto LF after CR On Off	Specifies whether the printer automatically performs a line feed after a carriage return control command <b>Note:</b> Off is the factory default setting.



Menu item	Description
<p><b>Tray Renumber</b></p> <p>Assign MP Feeder</p> <p>Off</p> <p>None</p> <p>0–199</p> <p>Assign Tray &lt;x&gt;</p> <p>Off</p> <p>None</p> <p>0–199</p> <p>Assign Manual Paper</p> <p>Off</p> <p>None</p> <p>0–199</p> <p>Assign Man Env</p> <p>Off</p> <p>None</p> <p>0–199</p>	<p>Configures the printer to work with printer software or programs that use different source assignments for trays, drawers, and feeders</p> <p><b>Notes:</b></p> <ul style="list-style-type: none"> <li>• Off is the factory default setting.</li> <li>• None is not an available selection. It appears only when it is selected by the PCL 5 interpreter.</li> <li>• None ignores the Select Paper Feed command.</li> <li>• 0–199 allows a custom setting to be assigned.</li> </ul>
<p><b>Tray Renumber</b></p> <p>View Factory Def</p> <p>MPF Default = 8</p> <p>T1 Default = 1</p> <p>T2 Default = 4</p> <p>T3 Default = 5</p> <p>T4 Default = 20</p> <p>T5 Default = 21</p> <p>Env Default = 6</p> <p>MPaper Default = 2</p> <p>MEnv Default = 3</p>	<p>Lets you view the factory default setting assigned to each tray, drawer, or feeder, even if it has not been installed</p>
<p><b>Tray Renumber</b></p> <p>Restore Defaults</p> <p>Yes</p> <p>No</p>	<p>Returns all tray, drawer, and feeder assignments to the factory default settings</p>

## HTML menu

Menu item		Description
<b>Font Name</b> Albertus MT Antique Olive Apple Chancery Arial MT Avant Garde Bodoni Bookman Chicago Clarendon Cooper Black Copperplate Coronet Courier Eurostile Garamond Geneva Gill Sans Goudy Helvetica Hoefler Text	Intl CG Times Intl Courier Intl Univers Joanna MT Letter Gothic Lubalin Gothic Marigold MonaLisa Recut Monaco New CenturySbk New York Optima Oxford Palatino StempelGaramond Taffy Times TimesNewRoman Univers Zapf Chancery	Sets the default font for HTML documents  <b>Notes:</b> <ul style="list-style-type: none"> <li>• The Times font will be used in HTML documents that do not specify a font.</li> <li>• The following fonts appear only if the appropriate DBCS font card is installed: HG-GothicB, MSung-Light, MD_DotumChe, and MingMT-Light.</li> </ul>

Menu item	Description
<b>Font Size</b> 1–255 pt	Sets the default font size for HTML documents  <b>Notes:</b> <ul style="list-style-type: none"> <li>• 12 pt is the factory default setting.</li> <li>• Font size can be increased in 1-point increments.</li> </ul>
<b>Scale</b> 1–400%	Scales the default font for HTML documents  <b>Notes:</b> <ul style="list-style-type: none"> <li>• 100% is the factory default setting.</li> <li>• Scaling can be increased in 1% increments.</li> </ul>
<b>Orientation</b> Portrait Landscape	Sets the page orientation for HTML documents  <b>Note:</b> Portrait is the factory default setting.
<b>Margin Size</b> 8–255 mm	Sets the page margin for HTML documents  <b>Notes:</b> <ul style="list-style-type: none"> <li>• 19 mm is the factory default setting.</li> <li>• Margin size can be increased in 1-mm increments.</li> </ul>

Menu item	Description
<b>Backgrounds</b> Do Not Print Print	Specifies whether to print backgrounds on HTML documents <b>Note:</b> Print is the factory default setting.

## Image menu

Menu item	Description
<b>Auto Fit</b> On Off	Selects the optimal paper size, scaling, and orientation <b>Notes:</b> <ul style="list-style-type: none"> <li>• On is the factory default setting.</li> <li>• The On setting overrides scaling and orientation settings for some images.</li> </ul>
<b>Invert</b> On Off	Inverts bi-tonal monochrome images <b>Notes:</b> <ul style="list-style-type: none"> <li>• Off is the factory default setting.</li> <li>• The font size can be increased in 1-point increments.</li> <li>• This setting does not apply to GIF or JPEG images.</li> </ul>
<b>Scaling</b> Anchor Top Left Best Fit Anchor Center Fit Height/Width Fit Height Fit Width	Scales the image to fit the selected paper size <b>Notes:</b> <ul style="list-style-type: none"> <li>• Best Fit is the factory default setting.</li> <li>• When Auto Fit is set to On, Scaling is automatically set to Best Fit.</li> </ul>
<b>Orientation</b> Portrait Landscape Rev Portrait Rev Landscape	Sets the image orientation <b>Note:</b> Portrait is the factory default setting.

## XPS menu

Menu item	Description
<b>Print Error Pages</b> Off On	Prints a page containing information on errors, including XML markup errors <b>Note:</b> Off is the factory default setting.

# Help menu

The Help menu consists of Help pages that are stored in the printer as PDFs. They contain reference information about using the printer and performing tasks. You may select to print each one individually, or select **Print all guides** to print all of them at one time.

English, French, German, and Spanish translations are stored in the printer. Other translations are available on the *Software and Documentation CD*.

Menu item	Description
Print all guides	Prints all the guides
Copy guide	Provides information about making copies and changing settings
E-mail guide	Provides information about sending e-mails using addresses, shortcut numbers, or the address book, and changing settings
Fax guide	Provides information about sending faxes using fax numbers, shortcut numbers, or the address book, and changing settings
FTP guide	Provides information about scanning documents directly to an FTP server using an FTP address, shortcut numbers, or the address book, and changing settings
Information guide	Provides help in locating additional information
Print defects guide	Provides help in resolving repeating defects in copies or prints

# Understanding printer messages

## List of status and error messages

### Answering

The printer is answering a fax call. Wait for the message to clear.

### Busy

Wait for the message to clear.

### Call complete

A fax call is completed. Wait for the message to clear.

### Change <src> to <x>

<src> is a tray or feeder, and <x> is a paper size or type.

You can change the current paper source for the remainder of the print job. The formatted page will print on the paper loaded in the selected tray. This may cause clipping of text or images. Try one or more of the following:

- Select the paper tray with the correct paper size or type.
- Touch **Use current [src]** to ignore the message and print from the tray selected for the print job.
- Touch **Continue** to continue the job if the correct size and type are loaded in the tray, and this size and type are specified in the printer control panel Paper menu.

**Note:** If you touch Continue when there is no paper in the tray, the job is not continued.

- Touch **Cancel job** to cancel the current job.

### Check tray <x> connection

Try one or more of the following:

- Turn the printer off and then back on.

If the error occurs a second time:

- 1 Turn the printer off.
- 2 Unplug the power cord from the wall outlet.
- 3 Remove the tray.
- 4 Reattach the tray.
- 5 Connect the power cord to a properly grounded outlet.
- 6 Restart the printer.

If the error occurs again:

- 1 Turn the printer off.
  - 2 Unplug the power cord from the wall outlet.
  - 3 Remove the tray.
  - 4 Contact Customer Support.
- Touch **Continue** to clear the message and print without using the tray.

## Close door or insert cartridge

The cartridge is missing or not installed correctly. Insert the cartridge and close all doors and covers.

## Close finisher side door

Close the side door on the finisher.

## Connect <x>bps

The fax is connected. Wait for the message to clear.

**Note:** <x> is the baud rate per second.

## Dialing

A fax number is dialed. If the number is too long to fit on the screen, only the word **Dialing** appears. Wait for the message to clear.

## Disk corrupted

The printer attempted a hard disk recovery on a corrupted hard disk, and the hard disk cannot be repaired. The hard disk must be reformatted.

Touch **Reformat disk** to reformat the hard disk and clear the message.

**Note:** Reformatting the disk deletes all the files currently stored on the disk.

## Disk Full - Scan Job Canceled

The scan job canceled or stopped due to insufficient printer hard disk space.

Touch **Continue** to clear the message.

## Fax failed

The fax failed to be sent. Wait for the message to clear.

## Fax memory full

There is not enough memory to send the fax job.

Touch **Continue** to clear the message.

## Fax partition inoperative. Contact system administrator.

The fax partition appears to be corrupted. Try one or more of the following:

- Touch **Continue** to clear the message.
- Turn the printer off and then back on to reset the printer. If the message appears again, then contact your system support person.

## Fax server 'To Format' not set up. Contact system administrator.

The printer is in Fax Server mode, but the Fax Server setup has not been completed.

Try one or more of the following:

- Touch **Continue** to clear the message.
- Complete the Fax Server setup. If the message appears again, contact your system support person.

## Fax Station Name not set up

The Fax Station Name has not been entered. Sending and receiving faxes is disabled until fax is configured properly.

Try one or more of the following:

- Touch **Continue** to clear the message.
- Complete the Analog Fax Setup. If the message appears again, contact your system support person.

## Fax Station Number not set up

The Fax Station Number has not been entered. Sending and receiving faxes is disabled until fax is configured properly.

Try one or more of the following:

- Touch **Continue** to clear the message.
- Complete the Analog Fax Setup. If the message appears again, contact your system support person.

## Flushing buffer

Wait for the message to clear.

## Insert staple cartridge

Try one or more of the following:

- Insert a staple cartridge to clear the message.
- Touch **Continue** to clear the message and print without using the staple feature.

## Insert Tray <x>

Insert the specified tray into the printer.

## Install bin <x>

Try one or more of the following:

- Install the specified bin:
  - 1 Turn the printer off.
  - 2 Unplug the power cord from the wall outlet.
  - 3 Install the specified bin.
  - 4 Connect the power cord to a properly grounded outlet.
  - 5 Restart the printer.
- Cancel the current job.

## Install envelope feeder

Try one or more of the following:

- Install the envelope feeder:
  - 1 Turn the printer off.
  - 2 Unplug the power cord from the wall outlet.
  - 3 Install the envelope feeder.
  - 4 Connect the power cord to a properly grounded outlet.
  - 5 Restart the printer.
- Cancel the current job.

## Install Tray <x>

Try one or more of the following:

- Install the specified tray:
  - 1 Turn the printer off.
  - 2 Unplug the power cord from the wall outlet.
  - 3 Install the specified tray.
  - 4 Connect the power cord to a properly grounded outlet.
  - 5 Restart the printer.
- Cancel the current job.

## Invalid PIN

Enter a valid PIN.



## Job stored for delayed transmission

The scanning completed for a delayed send fax job. Wait for the message to clear.

## Line busy

A fax number is dialed, but the fax line is busy. Wait for the message to clear.

## Load <src> with <x>

<src> is a tray or feeder, and <x> is a paper type or size.

Try one or more of the following:

- Load the specified paper in the tray.
- Touch **Continue** to clear the message and continue printing.

If the printer finds a tray that has the correct paper type and size, it feeds from that tray. If the printer cannot find a tray with the correct paper type and size, it prints from the default source.

- Cancel the current job.

## Load manual feeder with <x>

<x> is a paper type or size.

Try one or more of the following:

- Load the specified paper in the multipurpose feeder.
- Touch **Continue** to clear the message and continue printing.

If the printer finds a tray that has the correct paper type and size, then it feeds from that tray. If the printer cannot find a tray with the correct paper type and size, then it prints from the default source.

- Cancel the current job.

## Load staples

Try one or more of the following:

- Replace the specified staple cartridge in the finisher.
- Touch **Continue** to clear the message and continue printing.
- Touch **Cancel job** to cancel the print job.

## Memory full, cannot print faxes

There is not enough memory to print the fax job.

Touch **Continue** to clear the message without printing. Held faxes will attempt to print after the printer has been restarted.

## Network/Network <x>

The printer is connected to the network.

**Network** indicates that the printer is using the standard network port built into the printer system board. **Network <x>** indicates that an internal print server is installed inside the printer or that the printer is connected to an external print server.

## No analog phone line connected to modem, fax is disabled.

The printer is not detecting an analog phone line, so the fax is disabled. Connect the printer to an analog phone line.

## No answer

A fax number is dialed, but no connection is made. Wait for the message to clear.

## No dial tone

The printer does not have a dial tone. Wait for the message to clear.

## Queued for sending

The scanning process of a fax job completed, but the job is not sent yet because another fax job is being sent or received. Wait for the message to clear.

## Ready

The printer is ready to receive print jobs.

## Reattach bin <x>

Try one or more of the following:

- Turn the printer off and then back on.

If the error occurs a second time:

- 1 Turn the printer off.
- 2 Unplug the power cord from the wall outlet.
- 3 Remove the specified bin.
- 4 Reattach the bin.
- 5 Connect the power cord to a properly grounded outlet.
- 6 Restart the printer.

If the error occurs again:

- 1 Turn the printer off.
  - 2 Unplug the power cord from the wall outlet.
  - 3 Remove the specified bin.
  - 4 Contact Customer Support.
- Touch **Continue** to clear the message and print without using the specified bin.

## Reattach bin <x> – <y>

Try one or more of the following:

- Turn the printer off and then back on.

If the error occurs a second time:

- 1 Turn the printer off.
- 2 Unplug the power cord from the wall outlet.
- 3 Remove the specified bins.
- 4 Reattach the bins.
- 5 Connect the power cord to a properly grounded outlet.
- 6 Restart the printer.

If the error occurs again:

- 1 Turn the printer off.
  - 2 Unplug the power cord from the wall outlet.
  - 3 Remove the specified bins.
  - 4 Contact Customer Support.
- Touch **Continue** to clear the message and print without using the specified bins.

## Reattach envelope feeder

Try one or more of the following:

- Turn the printer off and then back on.

If the error occurs a second time:

- 1 Turn the printer off.
- 2 Unplug the power cord from the wall outlet.
- 3 Remove the envelope feeder.
- 4 Reattach the envelope feeder.
- 5 Connect the power cord to a properly grounded outlet.
- 6 Restart the printer.

If the error occurs again:

- 1 Turn the printer off.
  - 2 Unplug the power cord from the wall outlet.
  - 3 Remove the envelope feeder.
  - 4 Contact Customer Support.
- Touch **Continue** to clear the message and print without using the envelope feeder.

## Receive complete

The printer has received an entire fax job. Wait for the message to clear.

## Receiving page <n>

The printer receives page <n> of the fax job, where <n> is the number of the page received. Wait for the message to clear.

## Remove packaging material, check <x>

Remove any remaining packaging material from the specified location.

## Remove paper from <linked bin set name>

Remove the paper from the specified bin. The printer automatically senses paper removal and resumes printing.

If removing the paper does not clear the message, then touch **Continue**.

## Remove paper from all bins

Remove the paper from all of the bins. The printer automatically senses paper removal and resumes printing.

If removing the paper does not clear the message, then touch **Continue**.

## Remove paper from bin <x>

Remove the paper from the specified bin. The printer automatically senses paper removal and resumes printing.

If removing the paper does not clear the message, then touch **Continue**.

## Remove paper from standard output bin

Remove the stack of paper from the standard exit bin.

## Replace <x> if restarting job.

One or more messages which interrupted a scan job are now cleared. Replace the original documents in the scanner to restart the scan job. <x> is a page of the scan job.

Try one or more of the following:

- Touch **Cancel Job** if a scan job is processing when the message appears. This cancels the job and clears the message.
- Touch **Scan from Automatic Document Feeder** if the page jam recovery is active. Scanning resumes from the ADF immediately after the last successfully scanned page.
- Touch **Scan from flatbed** if page jam recovery is active. Scanning resumes from the scanner glass immediately after the last successfully scanned page.
- Touch **Finish job without further scanning** if page jam recovery is active. The job ends at the last successfully scanned page, but the job is not canceled. Successfully scanned pages go to their destination: copy, fax, e-mail, or FTP.
- Touch **Restart job** if job recovery is active. The message clears. A new scan job containing the same parameters as the previous job starts.

## Replace wiper

Replace the fuser wiper, or try one or more of the following:

- Touch **Continue** to clear the message and continue printing.
- Touch **Ignore** to clear the message, but at the next power-on, the message appears again.

## Restore Held Jobs?

Try one or more of the following:

- Touch **Continue** to restore all held jobs stored on the printer hard disk.
- Touch **Do not restore** if you do not want any print jobs to be restored.

## Scan Document Too Long

The scan job exceeds the maximum number of pages. Touch **Cancel Job** to clear the message.

## Scanner ADF Cover Open

The ADF cover is open. The message clears when the cover is closed.

## Scanner Jam Access Cover Open

Close the bottom ADF door to clear the message.

## Securely clearing disk space

The printer hard disk wiping process needs to recover. The message clears when all blocks are cleared.

## Sending page <n>

The printer sends page <n> of the fax job, where <n> is the number of the page sent. Wait for the message to clear.

## Serial <x>

The printer is using a serial cable connection. The serial port is the active communication link.

## Set clock

The clock is not set. This message appears if no other fax status message appears. It remains until the clock is set.

## SMTP server not set up. Contact system administrator.

An error occurred on the SMTP server, or the SMTP server is not configured properly. Touch **Continue** to clear the message. If the message appears again, contact your system support person.

## **Some held jobs were not restored**

Touch **Continue** to delete the specified job.

**Note:** Some held jobs are not restored. They stay on the hard disk and are inaccessible.

## **System busy, preparing resources for job.**

Not all resources needed for the job are available. Wait for the message to clear.

## **System busy, preparing resources for job. Deleting held job(s).**

Not all resources needed for the job are available. Some held jobs are deleted to free system memory. Wait for the message to clear.

## **Unsupported disk**

An unsupported printer hard disk has been installed. Remove the unsupported device, and then install a supported one.

## **Unsupported USB device, please remove**

Remove the unrecognized USB device.

## **Unsupported USB hub, please remove**

Remove the unrecognized USB hub.

## **USB/USB <X>**

The printer is using a USB cable connection. The USB port is the active communication link.

## **Waiting for redial**

The printer is waiting to redial the fax number. Wait for the message to clear.

## **30 Invalid refill, change cartridge**

Remove the print cartridge, and then install a supported one.

## **31 Replace defective cartridge**

Remove the defective print cartridge, and then install a new one.

## **32 Cartridge part number unsupported by device**

Remove the print cartridge, and then install a supported one.

## 34 Short paper

Try one or more of the following:

- Load the appropriate paper or other specialty media in the proper tray.
- Touch **Continue** to clear the message and print the job using a different paper tray.
- Check tray length and width guides and make sure the paper is properly loaded in the tray.
- Check the Print Properties or Print dialog settings to make sure the print job is requesting the correct paper size and type.
- Check that the paper size is correctly set. For example, if the MP Feeder Size is set to Universal, make sure the paper is large enough for the data being printed.
- Cancel the current print job.

## 35 Insufficient memory to support Resource Save feature

Try one or more of the following:

- Touch **Continue** to disable Resource Save and continue printing.
- To enable Resource Save after receiving this message, make sure the link buffers are set to Auto, and then exit the menus to activate the link buffer changes. When **Ready** appears, enable Resource Save.
- Install additional memory.

## 37 Insufficient memory to collate job

Try one or more of the following:

- Touch **Continue** to print the portion of the job already stored and begin collating the rest of the print job.
- Cancel the current print job.

## 37 Insufficient memory for Flash Memory Defragment operation

Try one or more of the following:

- Touch **Continue** to stop the defragment operation and continue printing.
- Delete fonts, macros, and other data in printer memory.
- Install additional printer memory.

## 37 Insufficient memory, some Held Jobs were deleted

The printer deleted some held jobs in order to process current jobs.

Touch **Continue** to clear the message.

## 37 Insufficient memory, some held jobs will not be restored

The printer was unable to restore some or all of the confidential or held jobs on the printer hard disk.

Touch **Continue** to clear the message.

## 38 Memory full

Try one or more of the following:

- Touch **Continue** to clear the message.
- Cancel the current print job.
- Install additional printer memory.

## 39 Complex page, some data may not have printed

Try one or more of the following:

- Touch **Continue** to clear the message and continue printing.
- Cancel the current print job.
- Install additional printer memory.

## 42.xy Cartridge region mismatch

Install a print cartridge that matches the region number of the printer. x indicates the value of the printer region. y indicates the value of the cartridge region. x and y can have the following values:

1	US
2	Europe, the Middle East, and Africa
3	Asia
4	Latin America
9	Invalid region

## 50 PPDS font error

Try one or more of the following:

- Touch **Continue** to clear the message and continue printing.
- The printer cannot find a requested font. From the PPDS menu, select **Best Fit**, and then select **On**. The printer will find a similar font and reformat the affected text.
- Cancel the current print job.

## 51 Defective flash detected

Try one or more of the following:

- Touch **Continue** to clear the message and continue printing.
- Cancel the current print job.



## 52 Not enough free space in flash memory for resources

Try one or more of the following:

- Touch **Continue** to clear the message and continue printing.  
Downloaded fonts and macros not previously stored in flash memory are deleted.
- Delete fonts, macros, and other data stored in flash memory.
- Upgrade to a larger capacity flash memory card.

## 53 Unformatted flash detected

Try one or more of the following:

- Touch **Continue** to stop the defragment operation and continue printing.
- Format the flash memory. If the error message remains, the flash memory may be defective and require replacing.

## 54 Network <x> software error

<x> is the number of the network connection.

Try one or more of the following:

- Touch **Continue** to continue printing.
- Turn the printer off and then back on to reset the printer.
- Upgrade (flash) the network firmware in the printer or print server.

## 54 Serial option <x> error

<x> is the number of the serial option.

Try one or more of the following:

- Check that the serial cable is connected correctly and is the proper one for the serial port.
- Check that the serial interface parameters (protocol, baud, parity, and data bits) are set correctly on the printer and host computer.
- Touch **Continue** to continue printing.
- Turn the printer power off and then back on to reset the printer.

## 54 Standard network software error

Try one or more of the following:

- Touch **Continue** to continue printing.
- Turn the printer off and then back on to reset the printer.
- Upgrade (flash) the network firmware in the printer or print server.

## 55 Unsupported option in slot <x>

<x> is a slot on the printer system board.

Try one or more of the following:

- 1 Turn the printer power off.
- 2 Unplug the power cord from the wall outlet.
- 3 Remove the unsupported option card from the printer system board.
- 4 Connect the power cord to a properly grounded outlet.
- 5 Turn the printer power back on.

## 56 Parallel port <x> disabled

<x> is the number of the parallel port.

Try one or more of the following:

- Touch **Continue** to clear the message.  
The printer discards any data received through the parallel port.
- Make sure the Parallel Buffer menu item is not set to Disabled.

## 56 Serial port <x> disabled

<x> is the number of the serial port.

Try one or more of the following:

- Touch **Continue** to clear the message.  
The printer discards any data received through the serial port.
- Make sure the Serial Buffer menu item is not set to Disabled.

## 56 Standard parallel port disabled

Try one or more of the following:

- Touch **Continue** to clear the message.  
The printer discards any data received through the parallel port.
- Make sure the Parallel Buffer menu item is not set to Disabled.

## 56 Standard USB port disabled

Try one or more of the following:

- Touch **Continue** to clear the message.  
The printer discards any data received through the USB port.
- Make sure the USB Buffer menu item is not set to Disabled.

## 56 USB port <x> disabled

<x> is the number of the USB port.

Try one or more of the following:

- Touch **Continue** to clear the message.  
The printer discards any data received through the USB port.
- Make sure the USB Buffer menu item is not set to Disabled.

## 57 Configuration change, held jobs were not restored

Since the time the jobs were stored on the printer hard disk something has changed in the printer to invalidate the held jobs. Possible changes include:

- The printer firmware has been updated.
- Paper input, output, or duplex options needed for the print job were removed.
- The print job was created using data from a device in the USB port and the device is no longer in the port.
- The printer hard disk contains jobs that were stored while installed in a different printer model.

Touch **Continue** to clear the message.

## 58 Too many bins attached

- 1 Turn the printer power off.
- 2 Unplug the power cord from the wall outlet.
- 3 Remove the additional bins.
- 4 Connect the power cord to a properly grounded outlet.
- 5 Turn the printer power back on.

## 58 Too many disks installed

- 1 Turn the printer off.
- 2 Unplug the power cord from the wall outlet.
- 3 Remove the extra disks.
- 4 Connect the power cord to a properly grounded outlet.
- 5 Turn the printer back on.

## 58 Too many flash options installed

- 1 Turn the printer off.
- 2 Unplug the power cord from the wall outlet.
- 3 Remove the excess flash memory.

- 4 Connect the power cord to a properly grounded outlet.
- 5 Turn the printer back on.

## 58 Too many trays attached

- 1 Turn the printer off.
- 2 Unplug the power cord from the wall outlet.
- 3 Remove the additional trays.
- 4 Connect the power cord to a properly grounded outlet.
- 5 Turn the printer back on.

## 59 Incompatible envelope feeder

Try one or more of the following:

- Remove the envelope feeder.
- Touch **Continue** to clear the message and continue printing without using the envelope feeder.

## 59 Incompatible output bin <x>

Try one or more of the following:

- Remove the specified output bin.
- Touch **Continue** to clear the message and continue printing without using the specified output bin.

## 59 Incompatible tray <x>

Try one or more of the following:

- Remove the specified tray.
- Touch **Continue** to clear the message and continue printing without using the specified tray.

## 61 Remove defective disk

Try one or more of the following:

- Touch **Continue** to clear the message and continue printing.
- Install a different printer hard disk before performing any operations that require a printer hard disk.

## 62 Disk full

Try one or more of the following:

- Touch **Continue** to clear the message and continue processing.
- Delete fonts, macros, and other data stored on the printer hard disk.
- Install a larger printer hard disk.

## 63 Unformatted disk

Try one or more of the following:

- Touch **Continue** to clear the message and continue printing.
- Format the printer hard disk.

If the error message remains, the hard disk may be defective and require replacing.

## 80 Routine maintenance needed

The printer needs to have routine maintenance done. Order a maintenance kit, which contains all the items necessary to replace the pick rollers, the charge roll, the transfer roller, and the fuser.

## 88 Cartridge low

The toner is low. Replace the print cartridge, and then touch **Continue** to clear the message and continue printing.

## 88.yy Cartridge nearly low

The toner is low. Replace the print cartridge, and then touch **Continue** to clear the message and continue printing.

## 88.yy Replace cartridge

The print cartridge is empty.

- 1 Replace the print cartridge.
- 2 Touch **Continue** to clear the message.

## 200–282.yy paper jam

- 1 Clear the paper path.
- 2 Touch **Continue** to continue printing.

## 283 Staple jam

- 1 Clear the jam from the specified stapler area(s).
- 2 Touch **Continue** to continue printing.

## 290-294.yy scanner jam

Clear all original documents from the scanner.

## 293 Replace all originals if restarting job.

The scanner was instructed to scan using the ADF but there is no paper in the ADF. Load paper in the ADF.

Try one or more of the following:

- Touch **Continue** if no scan job is active when the attendance message appears. This clears the message.
- Touch **Cancel Job** if a scan job is processing when the attendance message appears. This cancels the job and clears the message.
- Touch **Scan from Automatic Document Feeder** if the page jam recovery is active. Scanning resumes from the ADF immediately after the last successfully scanned page.
- Touch **Scan from flatbed** if page jam recovery is active. Scanning resumes from the flatbed immediately after the last successfully scanned page.
- Touch **Finish job** without further scanning if page jam recovery is active. The job ends at the last successfully scanned page, but the job is not canceled. Successfully scanned pages go to their destination: copy, fax, e-mail, or FTP.
- Touch **Restart job** if job recovery is active and you are able to restart the job. The message clears. A new scan job containing the same parameters as the previous job starts.

## 293.02 Flatbed Cover Open

Close the scanner cover.

## 840.01 Scanner Disabled

This message indicates that the scanner has been disabled by the system support person.

## 841-846 Scanner Service Error

- 1 Turn the printer off.
- 2 Unplug the power cord from the wall outlet.
- 3 Check all cable connections.
- 4 Connect the power cord to a properly grounded outlet.
- 5 Turn the printer back on.

If the service message appears again, then contact Customer Support, and report the message.

## 900–999 Service <message>

- 1 Turn the printer off.
- 2 Unplug the power cord from the wall outlet.
- 3 Check all cable connections.
- 4 Connect the power cord to a properly grounded outlet.
- 5 Turn the printer back on.

If the service message appears again, contact Customer Support, and report the message.

## **1565 Emulation error, load emulation option**

The printer automatically clears the message in 30 seconds and then disables the download emulator on the firmware card.

# Maintaining the printer

Periodically, certain tasks are required to maintain optimum print quality.

## Cleaning the exterior of the printer

- 1 Make sure that the printer is turned off and unplugged from the wall outlet.

 **CAUTION—SHOCK HAZARD:** To avoid the risk of electric shock when cleaning the exterior of the printer, unplug the power cord from the wall outlet and disconnect all cables to the printer before proceeding.

- 2 Remove paper from the standard exit bin.

- 3 Dampen a clean, lint-free cloth with water.

**Warning—Potential Damage:** Do not use household cleaners or detergents, as they may damage the finish of the printer.

- 4 Wipe only the outside of the printer, making sure to include the standard exit bin.

**Warning—Potential Damage:** Using a damp cloth to clean the interior may cause damage to your printer.

- 5 Make sure the paper support and standard exit bin are dry before beginning a new print job.

## Cleaning the scanner glass

Clean the scanner glass if you encounter print quality problems, such as streaks on copied or scanned images.

- 1 Slightly dampen a soft, lint-free cloth or paper towel with water.
- 2 Open the scanner cover.

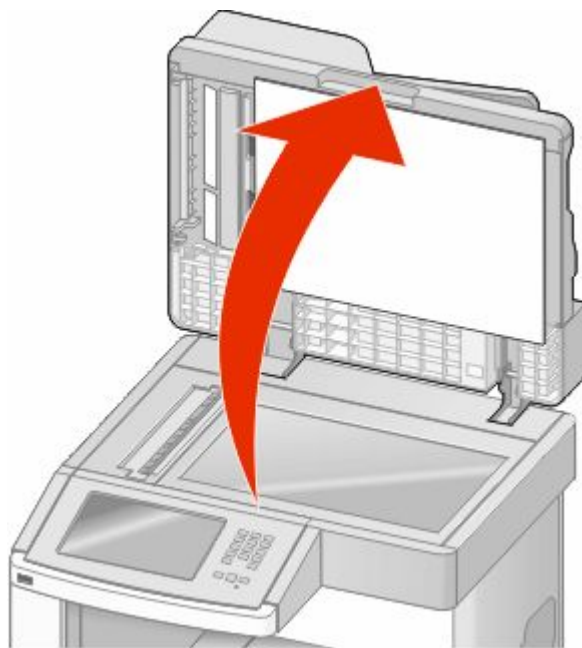

- 3 Wipe the scanner glass until it is clean and dry.



- 4 Wipe the white underside of the scanner cover until it is clean and dry.
- 5 Open the bottom ADF door.

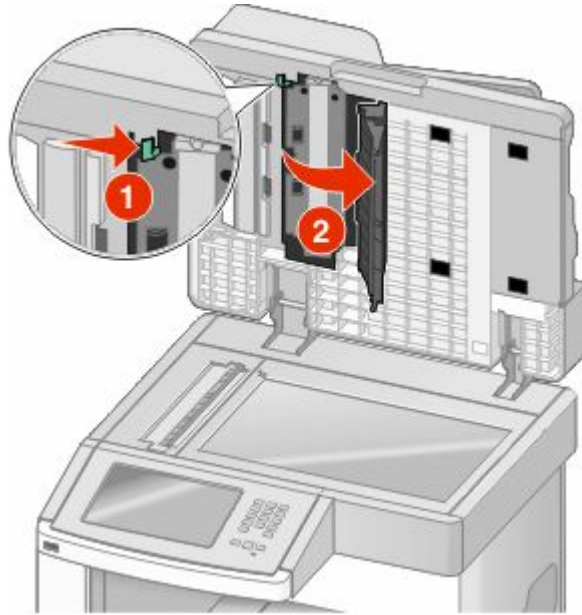

- 6 Wipe the ADF scanner glass under the ADF door.
- 7 Close the bottom ADF door.
- 8 Wipe the scanner glass (flatbed) and backing material by moving the cloth or paper towel from side to side.
- 9 Close the scanner cover.

## Adjusting scanner registration

Scanner Registration is a process to align the scan area with the paper location. To manually adjust the scanner registration:

- 1 Turn the printer off.
- 2 Clean the scanner glass and backing material.
- 3 Hold down **2** and **6** while turning the printer on.
- 4 Release the buttons when the screen with the progress bar appears.  
The printer performs a power-on sequence, and then the Configuration menu appears.
- 5 Touch the down arrow until **Scanner Manual Registration** appears.
- 6 Touch **Scanner Manual Registration**.
- 7 Touch **Print Quick Test** to print a registration page.
- 8 Choose the section of the scanner to align.

To align the scanner glass (flatbed):

- a Place the Quick Test page facedown on the scanner glass.

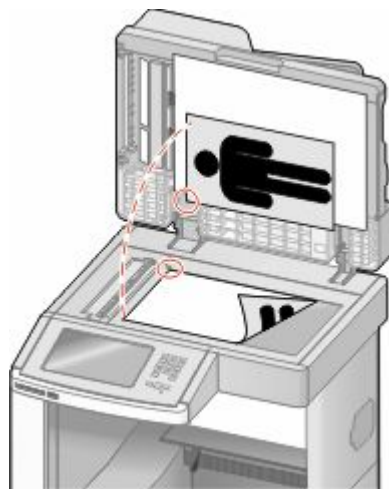

- b Touch **Copy Quick Test**.

The scanner prints a copy of the Quick Test page.

- c Touch **Flatbed**.

- d Use the copy of the Quick Test page to adjust the Left Margin and Top Margin settings.

- e Touch **Submit**.

- f Touch **Copy Quick Test** and compare the new copy to the original.

Repeat the flatbed alignment steps until the position on the page of the Quick Test copy closely matches the original.

To align the ADF:

- a Do one of the following:

- To align the ADF front: place the Quick Test page faceup, short edge first into the ADF.
- To align the ADF back: place the Quick Test page facedown, short edge first into the ADF.

- b Touch **Copy Quick Test**.

The scanner prints a copy of the Quick Test page.

- c Touch **ADF Front** or **ADF Back**.

- d Use the copy of the Quick Test page to adjust the Horizontal Adjust and Top Margin settings.

- e Touch **Submit**.

- f Touch **Copy Quick Test** and compare the new copy to the original.

Repeat the ADF alignment steps until the position on the page of the Quick Test copy closely matches the original.

- 9 Touch **Back**.

- 10 Touch **Exit Configuration**.

## Storing supplies

Choose a cool, clean storage area for the printer supplies. Store supplies right side up in their original packing until you are ready to use them.

Do not expose supplies to:

- Direct sunlight
- Temperatures above 35°C (95°F)
- High humidity above 80%
- Salty air
- Corrosive gases
- Heavy dust

## Conserving supplies

There are some settings you can change from the printer control panel that will help you conserve toner and paper. For more information, see “Supplies menu,” “Quality menu,” and “Finishing menu.”

If you need to print several copies, you can conserve supplies by printing the first copy and checking it for accuracy before printing the remaining copies.

## Checking the status of supplies

A message appears on the display when a replacement supply item is needed or when maintenance is required.

### Checking the status of supplies from the printer control panel

- 1 Make sure the printer is on and **Ready** appears.
- 2 On the home screen, touch **Status/Supplies**.

**Note:** If **Status/Supplies** is not on the home screen, then print a menu settings page to review the status of the supplies.

### Checking the status of supplies from a network computer

**Note:** The computer must be connected to the same network as the printer.

- 1 Type the printer IP address into the address field of your Web browser.

**Note:** If you do not know the IP address of the printer, print a network setup page and locate the IP address in the TCP/IP section.

- 2 Click **Device Status**. The Device Status page appears, displaying a summary of supply levels.

# Ordering supplies

To order supplies, contact the place where you purchased the printer.

**Note:** All life estimates for printer supplies assume printing on letter- or A4-size plain paper.

## Ordering print cartridges

When **88 Cartridge low** appears or when the print becomes faded:

- 1 Remove the print cartridge.
- 2 Firmly shake the cartridge side-to-side and front-to-back several times to redistribute toner.

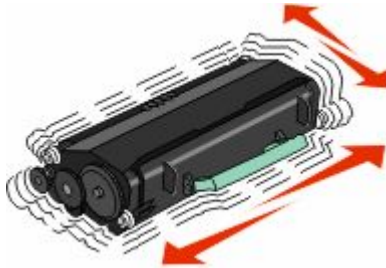

- 3 Reinsert the cartridge and continue printing.

**Note:** Repeat this procedure multiple times until the print remains faded, and then replace the cartridge.

# Moving the printer

## Before moving the printer

**CAUTION—POTENTIAL INJURY:** The printer weight is greater than 18 kg (40 lb) and requires two or more trained personnel to move it safely.



**CAUTION—POTENTIAL INJURY:** Before moving the printer, follow these guidelines to avoid personal injury or printer damage:

- Turn the printer off using the power switch, and then unplug the power cord from the wall outlet.
- Disconnect all cords and cables from the printer before moving it.

- Lift the printer off of the optional drawer and set it aside instead of trying to lift the drawer and printer at the same time.

**Notes:**

- Remove all printer options before moving the printer.
- Use the handholds located on both sides of the printer to lift it off the optional drawer.

**Warning—Potential Damage:** Damage to the printer caused by improper moving is not covered by the printer warranty.

## Moving the printer to another location

The printer and options can be safely moved to another location by following these precautions:

- Any cart used to move the printer must have a surface able to support the full footprint of the printer. Any cart used to move the options must have a surface able to support the dimensions of the options.
- Keep the printer in an upright position.
- Avoid severe jarring movements.

## Setting the printer up in a new location

Allow the following recommended amount of space around the printer:

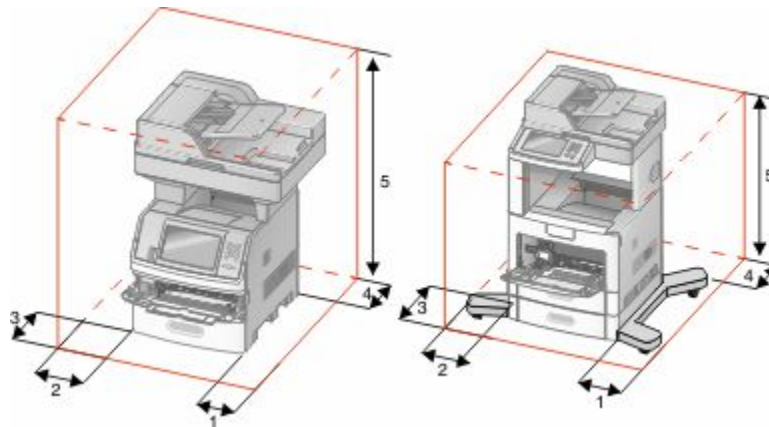

1	Right Side	20 cm (8 in.)
2	Left Side	31 cm (12 in.)
3	Front	51 cm (20 in.)
4	Rear	20 cm (8 in.)
5	Top	31 cm (12 in.)

## Shipping the printer

When shipping the printer, use the original packaging or call the place of purchase for a relocation kit.

# Administrative support

## Using the Embedded Web Server

If the printer is installed on a network, the Embedded Web Server is available for a range of functions including:

- Viewing a virtual display of the printer control panel
- Checking the status of the printer supplies
- Configuring printer settings
- Configuring network settings
- Viewing reports

To access the Embedded Web Server, type the printer IP address into the address field of your Web browser.

**Note:** If you do not know the IP address of the printer, then print a network setup page and locate the IP address in the TCP/IP section.

## Checking the device status

Using the Embedded Web Server, you can view paper tray settings, the level of toner in the print cartridge, the percentage of life remaining in the maintenance kit, and capacity measurements of certain printer parts. To view the device status:

- 1 Type the printer IP address in the address field of your Web browser.

**Note:** If you do not know the IP address of the printer, then print a network setup page and locate the IP address in the TCP/IP section.

- 2 Click **Device Status**.

## Setting up e-mail alerts

You can have the printer send you an e-mail when the supplies are getting low or when the paper needs to be changed, added, or unjammed.

To set up e-mail alerts:

- 1 Type the printer IP address into the address field of your Web browser.

**Note:** If you do not know the IP address of the printer, then print a network setup page and locate the IP address in the TCP/IP section.

- 2 Click **Settings**.

- 3 Under Other Settings, click **E-mail Alert Setup**.

- 4 Select the items for notification, and type in the e-mail addresses.

- 5 Click **Submit**.

**Note:** See your system support person to set up the e-mail server.

# Viewing reports



You can view some reports from the Embedded Web Server. These reports are useful for assessing the status of the printer, the network, and supplies.

To view reports from a network printer:

- 1 Type the printer IP address into the address field of your Web browser.  
**Note:** If you do not know the IP address of the printer, then print a network setup page and locate the IP address in the TCP/IP section.
- 2 Click **Reports**, and then click the type of report you want to view.

# Adjusting the brightness of the display

If you are having trouble reading your display, the LCD brightness can be adjusted through the Settings menu.

- 1 Make sure the printer is on and **Ready** appears.
- 2 On the home screen, touch .
- 3 Touch **Settings**.
- 4 Touch **General Settings**.
- 5 Touch the down arrow until **Screen Brightness** appears.
- 6 Touch the arrows to increase or decrease the brightness.  
Brightness settings can be adjusted from 20–100 (100 is the factory default setting).
- 7 Touch **Submit**.
- 8 Touch .

# Adjusting Power Saver



Available settings range from 1–240 minutes. The factory default is 30 minutes.

To increase or decrease the number of minutes before the printer enters Power Saver mode, do one of the following:

## Using the Embedded Web Server

- 1 Type the printer IP address into the address field of your Web browser.  
**Note:** If you do not know the IP address of the printer, then print a network setup page and locate the IP address in the TCP/IP section.
- 2 Click **Settings**, and then click **General Settings**.
- 3 Click **Timeouts**.
- 4 In the Power Saver box, increase or decrease the number of minutes you want the printer to wait before it enters Power Saver mode.
- 5 Click **Submit**.



## Using the printer control panel

- 1 Make sure the printer is on and **Ready** appears.
- 2 On the home screen, touch .
- 3 Touch **Settings**.
- 4 Touch **General Settings**.
- 5 Touch the down arrow until **Timeouts** appears.
- 6 Touch **Timeouts**.
- 7 Touch the left or right arrow next to **Power Saver Mode** to decrease or increase the time the printer waits before entering Power Saver mode.  
The settings available range from 1–240 minutes.
- 8 Touch **Submit**.
- 9 Touch .

## Restoring the factory default settings

If you want to retain a list of the current menu settings for reference, then print a menu settings page before you restore the factory default settings. For more information, see “Printing a menu settings page” on page 44.

**Warning—Potential Damage:** Restoring factory defaults returns most printer settings to the original factory default setting. Exceptions include the display language, custom sizes and messages, and Network/Port menu settings. All downloads stored in RAM are deleted. Downloads stored in flash memory or on a printer hard disk are not affected.

- 1 Make sure the printer is on and **Ready** appears.
- 2 On the home screen, touch .
- 3 Touch **Settings**.
- 4 Touch **General Settings**.
- 5 Touch the down arrow until **Factory Defaults** appears.
- 6 Touch the left or right arrow until **Restore Now** appears.
- 7 Touch **Submit**.
- 8 Touch .



# Troubleshooting

## Solving basic printer problems

If there are basic printer problems, or the printer is unresponsive, make sure:

- The power cord is plugged into the printer and a properly grounded electrical outlet.
- The electrical outlet is not turned off by any switch or breaker.
- The printer is not plugged into any surge protectors, uninterrupted power supplies, or extension cords.
- Other electronic equipment plugged into the outlet is working.
- The printer is turned on. Check the printer power switch.
- The printer cable is securely attached to the printer and the host computer, print server, option, or other network device.
- All options are properly installed.
- The printer driver settings are correct.

Once you have checked each of these possibilities, turn the printer off, wait for about 10 seconds, and then turn the printer back on. This often fixes the problem.

## Printer control panel display is blank or displays only diamonds

The printer self test failed. Turn the printer off, wait about 10 seconds, and then turn the printer on.

If **Ready** does not appear, then turn the printer off and contact Customer Support.

## Solving printing problems

### Multiple-language PDFs do not print

The documents contain unavailable fonts.

- 1 Open the document you want to print in Adobe Acrobat.
- 2 Click the printer icon.  
The Print dialog appears.
- 3 Select **Print as image**.
- 4 Click **OK**.

### Error message about reading USB drive appears

Make sure the USB drive is supported. For information regarding tested and approved USB flash memory devices, contact the place where you purchased your printer.

## Jobs do not print

These are possible solutions. Try one or more of the following:

### MAKE SURE THE PRINTER IS READY TO PRINT

Make sure **Ready** or **Power Saver** appears on the display before sending a job to print.

### CHECK TO SEE IF THE STANDARD EXIT BIN IS FULL

Remove the stack of paper from the standard exit bin.

### CHECK TO SEE IF THE PAPER TRAY IS EMPTY

Load paper in the tray.

### MAKE SURE THE CORRECT PRINTER SOFTWARE IS INSTALLED

- Verify that you are using the correct printer software.
- If you are using a USB port, make sure you are running a supported operating system and using compatible printer software.

### MAKE SURE THE INTERNAL PRINT SERVER IS INSTALLED PROPERLY AND WORKING

- Make sure the internal print server is properly installed and that the printer is connected to the network.
- Print a network setup page and check that the status shows **Connected**. If the status is **Not Connected**, check the network cables, and then try printing the network setup page again. Contact your system support person to make sure the network is functioning correctly.

### MAKE SURE YOU ARE USING A RECOMMENDED USB, SERIAL, OR ETHERNET CABLE

For more information contact the place where you bought the printer.

### MAKE SURE PRINTER CABLES ARE SECURELY CONNECTED

Check the cable connections to the printer and print server to make sure they are secure.

For more information, see the setup documentation that came with the printer.

## Confidential and other held jobs do not print

These are possible solutions. Try one or more of the following:

### PARTIAL JOB, NO JOB, OR BLANK PAGES PRINT

The print job may contain a formatting error or invalid data.

- Delete the print job, and then print it again.
- For PDF documents, recreate the PDF and then print it again.

## MAKE SURE THE PRINTER HAS SUFFICIENT MEMORY

Free up additional printer memory by scrolling through the list of held jobs and deleting some of them.



## Job takes longer than expected to print

These are possible solutions. Try one or more of the following:

### REDUCE THE COMPLEXITY OF THE PRINT JOB

Eliminate the number and size of fonts, the number and complexity of images, and the number of pages in the job.

### CHANGE THE PAGE PROTECT SETTING TO OFF

- 1 Make sure the printer is on and **Ready** appears.
- 2 On the home screen, touch .
- 3 Touch **Settings**.
- 4 Touch **General Settings**.
- 5 Touch the down arrow until **Print Recovery** appears.
- 6 Touch **Print Recovery**.
- 7 Touch the right arrow next to **Page Protect** until **Off** appears.
- 8 Touch **Submit**.
- 9 Touch .

## Job prints from the wrong tray or on the wrong paper

### CHECK THE PAPER TYPE SETTING

Make sure the paper type setting matches the paper loaded in the tray:

- 1 From the printer control panel, check the Paper Type setting from the Paper menu.
- 2 Before sending the job to print, specify the correct type setting:
  - For Windows users, specify the type from Print Properties.
  - For Macintosh users, specify the type from the Print dialog.

## Incorrect characters print

### MAKE SURE THE PRINTER IS NOT IN HEX TRACE MODE

If **Ready Hex** appears on the display, then you must exit Hex Trace mode before you can print your job. Turn the printer off and back on to exit Hex Trace mode.

## Tray linking does not work

These are possible solutions. Try one or more of the following:

### LOAD THE SAME SIZE AND TYPE OF PAPER

- Load the same size and type of paper in each tray to be linked.
- Move the paper guides to the correct positions for the paper size loaded in each tray.

### USE THE SAME PAPER SIZE AND PAPER TYPE SETTINGS

- Print a menu settings page and compare the settings for each tray.
- If necessary, adjust the settings from the Paper Size/Type menu.

**Note:** The multipurpose feeder does not automatically sense the paper size. You must set the size from the Paper Size/Type menu.

## Large jobs do not collate

These are possible solutions. Try one or more of the following:

### MAKE SURE COLLATE IS SET TO ON

From the Finishing menu or Print Properties, set Collate to On.

**Note:** Setting Collate to Off in the software overrides the setting in the Finishing menu.

### REDUCE THE COMPLEXITY OF THE PRINT JOB

Reduce the complexity of the print job by eliminating the number and size of fonts, the number and complexity of images, and the number of pages in the job.

### MAKE SURE THE PRINTER HAS ENOUGH MEMORY

Add printer memory or an optional hard disk.

## Unexpected page breaks occur

### INCREASE THE PRINT TIMEOUT VALUE

- 1 Make sure the printer is on and **Ready** appears.
- 2 On the home screen, touch .
- 3 Touch **Settings**.
- 4 Touch **General Settings**.
- 5 Touch the down arrow until **Timeouts** appears.
- 6 Touch **Timeouts**.
- 7 Touch the left or right arrow next to **Print Timeout** until the desired value appears.

8 Touch **Submit**.

9 Touch .

## Solving copy problems

### Copier does not respond

These are possible solutions. Try one or more of the following:

#### CHECK THE DISPLAY FOR ERROR MESSAGES

Clear any error messages.

#### CHECK THE POWER

Make sure the printer is plugged in, the power is on, and **Ready** appears.

### Scanner unit does not close

Make sure there are no obstructions:

- 1 Lift the scanner unit.
- 2 Remove any obstruction keeping the scanner unit open.
- 3 Lower the scanner unit.

### Poor copy quality

These are some examples of poor copy quality:

- Blank pages
- Checkerboard pattern
- Distorted graphics or pictures
- Missing characters
- Faded print
- Dark print
- Skewed lines
- Smudges
- Streaks
- Unexpected characters
- White lines in print

These are possible solutions. Try one or more of the following:

#### CHECK THE DISPLAY FOR ERROR MESSAGES

Clear any error messages.

## **THE TONER MAY BE LOW**

When **88 Cartridge low** appears or when the print becomes faded, replace the print cartridge.

## **THE SCANNER GLASS MAY BE DIRTY**

Clean the scanner glass with a clean, lint-free cloth dampened with water. For more information, see “Cleaning the scanner glass” on page 248.

## **THE COPY IS TOO LIGHT OR TOO DARK**

Adjust the density of the copy.

## **CHECK THE QUALITY OF THE ORIGINAL DOCUMENT**

Make sure the quality of the original document is satisfactory.

## **CHECK THE DOCUMENT PLACEMENT**

Make sure the document or photo is loaded facedown on the scanner glass in the upper left corner.

## **UNWANTED TONER IS IN THE BACKGROUND**

- Increase the background removal setting.
- Adjust the darkness to a lighter setting.

## **PATTERNS (MOIRÉ) APPEAR IN THE OUTPUT**

- On the Copy screen, select the Text/Photo or Printed Image icon.
- Rotate the original document on the scanner glass.
- On the Copy screen, adjust the scale setting.

## **TEXT IS LIGHT OR DISAPPEARING**

- On the Copy screen, touch the Text icon.
- Decrease the background removal setting.
- Increase the contrast setting.
- Decrease the shadow detail setting.

## **THE OUTPUT APPEARS WASHED OUT OR OVEREXPOSED**

- On the Copy screen, select the Printed Image icon.
- Decrease the background removal setting.

## Partial document or photo copies

These are possible solutions. Try one or more of the following:

### CHECK THE DOCUMENT PLACEMENT

Make sure the document or photo is loaded facedown on the scanner glass in the upper left corner.

### CHECK THE PAPER SIZE SETTING

Make sure the paper size setting matches the paper loaded in the tray:

- 1 From the printer control panel, check the Paper Size setting from the Paper menu.
- 2 Before sending the job to print, specify the correct size setting:
  - For Windows users, specify the size from Print Properties.
  - For Macintosh users, specify the size from the Page Setup dialog.

## Solving scanner problems

### Checking an unresponsive scanner

If your scanner is not responding, then make sure:

- The printer is turned on.
- The printer cable is securely attached to the printer and the host computer, print server, option, or other network device.
- The power cord is plugged into the printer and a properly grounded electrical outlet.
- The electrical outlet is not turned off by any switch or breaker.
- The printer is not plugged into any surge protectors, uninterrupted power supplies, or extension cords.
- Other electrical equipment plugged into the outlet is working.

Once you have checked each of these possibilities, turn the printer off and then back on. This often fixes the problem with the scanner.

### Scan was not successful

These are possible solutions. Try one or more of the following:

#### CHECK THE CABLE CONNECTIONS

Make sure the network or USB cable is securely connected to the computer and the printer.

#### AN ERROR MAY HAVE OCCURRED IN THE PROGRAM

Turn off and then restart the computer.

## Scanning takes too long or freezes the computer

These are possible solutions. Try one or more of the following:

### **OTHER SOFTWARE PROGRAMS MAY BE INTERFERING WITH SCANNING**

Close all programs not being used.

### **THE SCAN RESOLUTION MAY BE SET TOO HIGH**

Select a lower scan resolution.

## Poor scanned image quality

These are possible solutions. Try one or more of the following:

### **CHECK THE DISPLAY FOR ERROR MESSAGES**

Clear any error messages.

### **THE SCANNER GLASS MAY BE DIRTY**

Clean the scanner glass with a clean, lint-free cloth dampened with water. For more information, see “Cleaning the scanner glass” on page 248.

### **ADJUST THE SCAN RESOLUTION**

Increase the resolution of the scan for a higher quality output.

### **CHECK THE QUALITY OF THE ORIGINAL DOCUMENT**

Make sure the quality of the original document is satisfactory.

### **CHECK THE DOCUMENT PLACEMENT**

Make sure the document or photo is loaded facedown on the scanner glass in the upper left corner.

## Partial document or photo scans

These are possible solutions. Try one or more of the following:

### **CHECK THE DOCUMENT PLACEMENT**

Make sure the document or photo is loaded facedown on the scanner glass in the upper left corner.



## CHECK THE PAPER SIZE SETTING

Make sure the paper size setting matches the paper loaded in the tray:

- 1 From the printer control panel, check the Paper Size setting from the Paper menu.
- 2 Before sending the job to print, specify the correct size setting:
  - For Windows users, specify the size from Print Properties.
  - For Macintosh users, specify the size from the Page Setup dialog.

## Cannot scan from a computer

These are possible solutions. Try one or more of the following:

### CHECK THE DISPLAY FOR ERROR MESSAGES

Clear any error messages.

### CHECK THE POWER

Make sure the printer is plugged in, the power is on, and **Ready** appears.

### CHECK THE CABLE CONNECTIONS

Make sure the network or USB cable is securely connected to the computer and the printer.

# Solving fax problems

## Caller ID is not shown

Contact your telecommunications company to verify that your telephone line is subscribed to the caller ID service.

If your region supports multiple caller ID patterns, you may have to change the default setting. There are two settings available: FSK (pattern 1) and DTMF (pattern 2). The availability of these settings by way of the Fax menu depends on whether your country or region supports multiple caller ID patterns. Contact your telecommunications company to determine which pattern or switch setting to use.

## Cannot send or receive a fax

These are possible solutions. Try one or more of the following:

### CHECK THE DISPLAY FOR ERROR MESSAGES

Clear any error messages.

### CHECK THE POWER

Make sure the printer is plugged in, the power is on, and **Ready** appears.

## CHECK THE PRINTER CONNECTIONS

Make sure the cable connections for the following hardware are secure, if applicable:

- Telephone
- Handset
- Answering machine

## CHECK THE TELEPHONE WALL JACK

- 1 Plug a telephone into the wall jack.
- 2 Listen for a dial tone.
- 3 If you do not hear a dial tone, then plug a different telephone into the wall jack.
- 4 If you still do not hear a dial tone, then plug a telephone into a different wall jack.
- 5 If you hear a dial tone, then connect the printer to that wall jack.

## REVIEW THIS DIGITAL PHONE SERVICE CHECKLIST

The fax modem is an analog device. Certain devices can be connected to the printer so that digital telephone services can be used.

- If you are using an ISDN telephone service, then connect the printer to an analog telephone port (an R-interface port) on an ISDN terminal adapter. For more information and to request an R-interface port, contact your ISDN provider.
- If you are using DSL, then connect to a DSL filter or router that will support analog use. For more information, contact your DSL provider.
- If you are using a PBX telephone service, then make sure you are connecting to an analog connection on the PBX. If none exists, consider installing an analog telephone line for the fax machine.

## CHECK FOR A DIAL TONE

- Place a test call to the telephone number to which you want to send a fax to make sure that it is working correctly.
- If the telephone line is being used by another device, then wait until the other device is finished before sending a fax.
- If you are using the On Hook Dial feature, then turn up the volume to verify a dial tone.

## TEMPORARILY DISCONNECT OTHER EQUIPMENT

To ensure the printer is working correctly, connect it directly to the telephone line. Disconnect any answering machines, computers with modems, or telephone line splitters.

## CHECK FOR JAMS

Clear any jams, and then make sure that **Ready** appears.

## TEMPORARILY DISABLE CALL WAITING

Call Waiting can disrupt fax transmissions. Disable this feature before sending or receiving a fax. Call your telephone company to obtain the keypad sequence for temporarily disabling Call Waiting.

## VOICE MAIL SERVICE MAY BE INTERFERING WITH THE FAX TRANSMISSION

Voice Mail offered through your local telephone company may disrupt fax transmissions. To enable both Voice Mail and the printer to answer calls, you may want to consider adding a second telephone line for the printer.

## THE PRINTER MEMORY MAY BE FULL

- 1 Dial the fax number.
- 2 Scan the original document one page at a time.

## Can send but not receive faxes

These are possible solutions. Try one or more of the following:

### CHECK TO SEE IF THE PAPER TRAY IS EMPTY

Load paper in the tray.

### CHECK THE RING COUNT DELAY SETTINGS

The ring count delay sets the number of times the phone line rings before the printer answers. If you have extension phones on the same line as the printer, or subscribe to the telephone company's Distinctive Ring service, then keep the Ring Delay setting at 4.

- 1 Type the printer IP address into the address field of your Web browser.  
**Note:** If you do not know the IP address of the printer, then print a network setup page and locate the IP address in the TCP/IP section.
- 2 Click **Settings**.
- 3 Click **Fax Settings**.
- 4 Click **Analog Fax Setup**.
- 5 In the Rings to Answer box, enter the number of times you want the phone to ring before answering.
- 6 Click **Submit**.

### THE TONER MAY BE LOW

88 Cartridge low appears when the toner is low.

## Can receive but not send faxes

These are possible solutions. Try one or more of the following:

### THE PRINTER IS NOT IN FAX MODE

On the home screen, touch **Fax** to put the printer in Fax mode.

### THE DOCUMENT IS NOT LOADED PROPERLY

Load the original document faceup, short edge first into the ADF or facedown on the scanner glass in the upper left corner.

**Note:** Do not load postcards, photos, small items, transparencies, photo paper, or thin media (such as magazine clippings) into the ADF. Place these items on the scanner glass.

### MAKE SURE THE SHORTCUT NUMBER IS SET UP PROPERLY

- Check to make sure the shortcut number has been programmed for the number that you want to dial.
- As an alternative, dial the telephone number manually.

## Received fax has poor print quality

These are possible solutions. Try one or more of the following:

### RE-SEND THE DOCUMENT

Ask the person who sent you the fax to:

- Check that the quality of the original document is satisfactory.
- Resend the fax. There may have been a problem with the quality of the telephone line connection.
- Increase the fax scan resolution, if possible.

### THE TONER MAY BE LOW

When **88 Cartridge low** appears or when you experience faded print, replace the cartridge.

### MAKE SURE THE FAX TRANSMISSION SPEED IS NOT SET TOO HIGH

Decrease the incoming fax transmission speed:

- 1 Type the printer IP address into the address field of your Web browser.

**Note:** If you do not know the IP address of the printer, then print a network setup page and locate the IP address in the TCP/IP section.

- 2 Click **Settings**.
- 3 Click **Fax Settings**.
- 4 Click **Analog Fax Setup**.

5 In the Max Speed box, click on one of the following:

**2400**

**4800**

**9600**

**14400**

**33600**

6 Click **Submit**.

## Solving option problems

### Option does not operate correctly or quits after it is installed

These are possible solutions. Try one or more of the following:

#### RESET THE PRINTER

Turn the printer off, wait about 10 seconds, and then turn the printer on.

#### CHECK TO SEE IF THE OPTION IS CONNECTED TO THE PRINTER

- 1 Turn the printer off.
- 2 Unplug the printer.
- 3 Check the connection between the option and the printer.

#### MAKE SURE THE OPTION IS INSTALLED CORRECTLY

Print a menu settings page and check to see if the option is listed in the Installed Options list. If the option is not listed, then reinstall it. For more information, see the hardware setup documentation that came with the option.

#### MAKE SURE THE OPTION IS SELECTED

From the computer you are printing from, select the option. For more information, see "Updating available options in the printer driver" on page 46.

## Paper trays

These are possible solutions. Try one or more of the following:

#### MAKE SURE THE PAPER IS LOADED CORRECTLY

- 1 Open the paper tray.
- 2 Check for paper jams or misfeeds.
- 3 Make sure paper guides are aligned against the edges of the paper.
- 4 Make sure the paper tray closes properly.

## **RESET THE PRINTER**

Turn the printer off, wait about 10 seconds, and then turn the printer on.

## **MAKE SURE THE PAPER TRAY IS INSTALLED CORRECTLY**

If the paper tray is listed on the menu settings page, but paper jams when it enters or exits the tray, then it may not be properly installed. Reinstall the paper tray. For more information, see the hardware setup documentation that came with the paper tray.

## **2000-sheet tray**

These are possible solutions. Try one or more of the following:

### **THE ELEVATOR TRAY IS NOT WORKING PROPERLY**

- Make sure the printer is properly connected to the 2000-sheet tray.
- Make sure the printer is turned on.

### **THE PAPER FEED ROLLERS DO NOT TURN TO ADVANCE PAPER**

- Make sure the printer is properly connected to the 2000-sheet tray.
- Make sure the printer is turned on.

## **Envelope feeder**

These are possible solutions. Try one or more of the following:

## **RESET THE PRINTER**

Turn the printer off, wait about 10 seconds, and then turn the printer on.

## **MAKE SURE THE ENVELOPES ARE LOADED CORRECTLY**

- 1 Adjust the envelope support for the length of envelope you are using.
- 2 For more information, see "Loading the envelope feeder" on page 80.

## **CHECK THE PAPER TYPE AND PAPER SIZE SETTINGS**

Make sure the paper type and paper size settings match the envelopes you are using:

- 1 From the printer control panel, check the settings for the envelope feeder from the Paper menu.
- 2 Before sending the job to print, specify the correct settings from the computer:
  - For Windows users, specify the settings from Print Properties.
  - For Macintosh users, specify the settings from the Print dialog.

## **MAKE SURE THE ENVELOPE FEEDER IS INSTALLED CORRECTLY**

If the envelope feeder is listed on the menu settings page, but an envelope jams when it enters or exits the envelope feeder, then it may not be properly installed. Reinstall the envelope feeder. For more information, see the hardware setup documentation that came with the envelope feeder.

## **Output options**

If the high capacity output expander, 4-bin mailbox, or StapleSmart finisher is listed on the menu settings page, but paper jams when it exits the printer or enters the output option, then it may not be properly installed. Reinstall the option. For more information, see the hardware setup documentation that came with the option.

## **Flash memory card**

Make sure the flash memory card is securely connected to the printer system board.

## **Hard disk with adapter**

Make sure the hard disk is securely connected to the printer system board.

## **Internal Solutions Port**

If the Internal Solutions Port (ISP) does not operate correctly, then these are possible solutions. Try one or more of the following:

### **CHECK THE ISP CONNECTIONS**

- Make sure the ISP is securely attached to the printer system board.
- Make sure the cable is securely connected to the correct connector.

### **CHECK THE CABLE**

Make sure you are using the correct cable and that it is securely connected.

## **MAKE SURE THE NETWORK SOFTWARE IS CONFIGURED CORRECTLY**

For information about installing software for network printing, see the *Networking Guide* on the *Software and Documentation CD*

## **Memory card**

Make sure the memory card is securely connected to the printer system board.

# Solving paper feed problems

## Paper frequently jams

These are possible solutions. Try one or more of the following:

### CHECK THE PAPER

Use recommended paper and specialty media. For more information, see the chapter about paper and specialty media guidelines.

### MAKE SURE THERE IS NOT TOO MUCH PAPER IN THE PAPER TRAY

Make sure the stack of paper you load does not exceed the maximum stack height indicated in the tray or on the multipurpose feeder.

### CHECK THE PAPER GUIDES

Move the guides in the tray to the correct positions for the paper size loaded.

### THE PAPER MAY HAVE ABSORBED MOISTURE DUE TO HIGH HUMIDITY

- Load paper from a fresh package.
- Store paper in its original wrapper until you use it.

## Paper jam message remains after jam is cleared

### CHECK THE PAPER PATH

The paper path is not clear. Clear jammed paper from the entire paper path, and then touch **Continue**.

## Page that jammed does not reprint after you clear the jam

### TURN ON JAM RECOVERY

In the Setup menu, Jam Recovery is set to Off. Set Jam Recovery to Auto or On:

- 1 Make sure the printer is on and **Ready** appears.
- 2 On the home screen, touch .
- 3 Touch **Settings**.
- 4 Touch **General Settings**.
- 5 Touch the down arrow until **Print Recovery** appears.
- 6 Touch **Print Recovery**.
- 7 Touch the right arrow next to **Jam Recovery** until **On** or **Auto** appears.



8 Touch **Submit**.



9 Touch .

## Solving print quality problems

The information in the following topics may help you solve print quality problems. If these suggestions still do not correct the problem, contact Customer Support. You may have a printer part that requires adjustment or replacement.

### Isolating print quality problems

To help isolate print quality problems, print the print quality test pages:

- 1 Turn the printer off.
- 2 Load Letter- or A4-size paper in the tray.
- 3 Hold down  and  while turning the printer on.
- 4 Release the buttons when the screen with the progress bar appears.  
The printer performs a power-on sequence, and then the Configuration menu appears.
- 5 Touch the down arrow until **Print Quality Pages** appears.
- 6 Touch **Print Quality Pages**.  
The print quality test pages print.
- 7 Touch **Back**.
- 8 Touch **Exit Configuration**.

### Blank pages

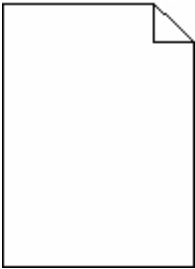

These are possible solutions. Try one or more of the following:

#### **P**ACKING MATERIAL MAY BE ON THE PRINT CARTRIDGE

Remove the print cartridge and make sure the packing material is properly removed. Reinstall the print cartridge.

#### **T**HE TONER MAY BE LOW

When **88 Cartridge low** appears, order a new print cartridge.

If the problem continues, the printer may need to be serviced. For more information, contact Customer Support.

## Characters have jagged or uneven edges



These are possible solutions. Try one or more of the following:

### CHECK THE PRINT QUALITY SETTINGS

- Change the Print Resolution setting in the Quality menu to 600 dpi, 1200 Image Q, 1200 dpi, or 2400 Image Q.
- Enable Enhance Fine Lines in the Quality menu.

### MAKE SURE DOWNLOADED FONTS ARE SUPPORTED

If you are using downloaded fonts, then verify that the fonts are supported by the printer, the host computer, and the software program.

## Clipped images

These are possible solutions. Try one or more of the following:

### CHECK THE GUIDES

Move the width and length guides in the tray to the correct positions for the paper size loaded.

### CHECK THE PAPER SIZE SETTING

Make sure the paper size setting matches the paper loaded in the tray:

- 1 From the printer control panel, check the Paper Size setting from the Paper menu.
- 2 Before sending the job to print, specify the correct size setting:
  - For Windows users, specify the size from Print Properties.
  - For Macintosh users, specify the size from the Page Setup dialog.

## Ghost images



## CHECK THE PAPER TYPE SETTING

Make sure the paper type setting matches the paper loaded in the tray:

- 1 From the printer control panel, check the Paper Type setting from the Paper menu.
- 2 Before sending the job to print, specify the correct type setting:
  - For Windows users, specify the type from Print Properties.
  - For Macintosh users, specify the type from the Print dialog.

## Gray background

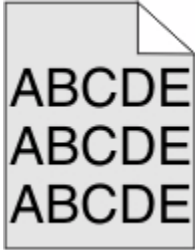

## CHECK THE TONER DARKNESS SETTING

Select a lighter Toner Darkness setting:

- From the printer control panel, change the setting from the Quality menu.
- For Windows users, change the setting from Print Properties.
- For Macintosh users, change the setting from the Print dialog.

## Incorrect margins

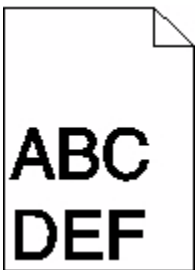

These are possible solutions. Try one or more of the following:

## CHECK THE PAPER GUIDES

Move the guides in the tray to the correct positions for the paper size loaded.

## CHECK THE PAPER SIZE SETTING

Make sure the paper size setting matches the paper loaded in the tray:

- 1 From the printer control panel, check the Paper Size setting from the Paper menu.
- 2 Before sending the job to print, specify the correct size setting:
  - For Windows users, specify the size from Print Properties.
  - For Macintosh users, specify the size from the Page Setup dialog.

## Paper curl

These are possible solutions. Try one or more of the following:

### CHECK THE PAPER TYPE SETTING

Make sure the paper type setting matches the paper loaded in the tray:

- 1 From the printer control panel, check the Paper Type setting from the Paper menu.
- 2 Before sending the job to print, specify the correct type setting:
  - For Windows users, specify the type from Print Properties.
  - For Macintosh users, specify the type from the Print dialog.

### THE PAPER HAS ABSORBED MOISTURE DUE TO HIGH HUMIDITY

- Load paper from a fresh package.
- Store paper in its original wrapper until you use it.

## Print irregularities

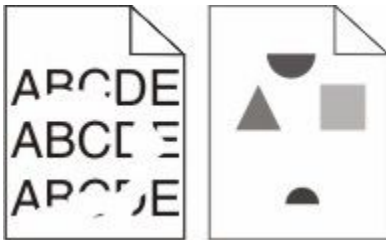

These are possible solutions. Try one or more of the following:

### THE PAPER MAY HAVE ABSORBED MOISTURE DUE TO HIGH HUMIDITY

- Load paper from a fresh package.
- Store paper in its original wrapper until you use it.

## CHECK THE PAPER TYPE SETTING

Make sure the paper type setting matches the paper loaded in the tray:

- 1 From the printer control panel, check the Paper Type setting from the Paper menu.
- 2 Before sending the job to print, specify the correct type setting:
  - For Windows users, specify the type from Print Properties.
  - For Macintosh users, specify the type from the Print dialog.

## CHECK THE PAPER

Avoid textured paper with rough finishes.

## THE TONER MAY BE LOW

When **88 Cartridge low** appears or when the print becomes faded, replace the print cartridge.

## THE FUSER MAY BE WORN OR DEFECTIVE

Replace the fuser.

## Repeating defects

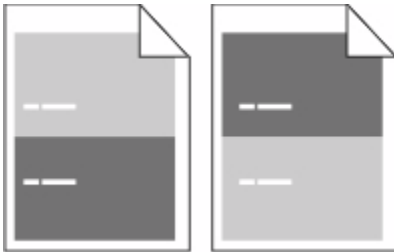

## REPEATING MARKS OCCUR EVENLY DOWN THE PAGE

Replace the charge rolls if the defects occur every 28.3 mm (1.11 in.).

Replace the transfer roller if the defects occur every 51.7 mm (2.04 in.).

Replace the print cartridge if the defects occur every:

- 47.8 mm (1.88 in.)
- 96.8 mm (3.81 in.)

Replace the fuser if the defects occur every:

- 88.0 mm (3.46 in.)
- 95.2 mm (3.75 in.)

## Skewed print

These are possible solutions. Try one or more of the following:

### CHECK THE PAPER GUIDES

Move the guides in the tray to the correct positions for the paper size loaded.

### CHECK THE PAPER

Make sure you are using paper that meets the printer specifications.

## Solid black or white streaks

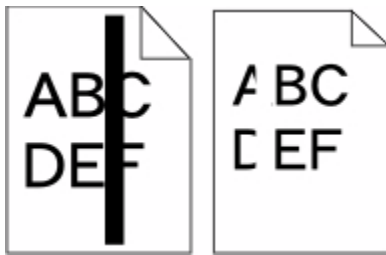

These are possible solutions. Try one or more of the following:

### MAKE SURE THE FILL PATTERN IS CORRECT

If the fill pattern is incorrect, then choose a different fill pattern from your software program or application.

### CHECK THE PAPER TYPE

- Try a different type of paper.
- Use only transparencies recommended by the printer manufacturer.
- Make sure the Paper Type and Paper Texture settings match the paper loaded in the tray or feeder.

### MAKE SURE THE TONER IS DISTRIBUTED EVENLY IN THE PRINT CARTRIDGE

Remove the print cartridge and shake it from side to side to redistribute the toner, and then reinstall it.

### THE PRINT CARTRIDGE MAY BE DEFECTIVE OR LOW ON TONER

Replace the used print cartridge with a new one.

## Print is too light



These are possible solutions. Try one or more of the following:

### CHECK THE DARKNESS, BRIGHTNESS, AND CONTRAST SETTINGS

The Toner Darkness setting is too light, the Brightness setting is too light, or the Contrast setting is too low.

- From the printer control panel, change these settings from the Quality menu.
- For Windows users, change these settings from Print Properties.
- For Macintosh users, change these settings from the Print dialog and pop-up menus.

### THE PAPER HAS ABSORBED MOISTURE DUE TO HIGH HUMIDITY

- Load paper from a fresh package.
- Store paper in its original wrapper until you use it.

### CHECK THE PAPER

Avoid textured paper with rough finishes.

### CHECK THE PAPER TYPE SETTING

Make sure the paper type setting matches the paper loaded in the tray:

- 1 From the printer control panel, check the Paper Type setting from the Paper menu.
- 2 Before sending the job to print, specify the correct type setting:
  - For Windows users, specify the type from Print Properties.
  - For Macintosh users, specify the type from the Print dialog.

### THE TONER IS LOW

When **88 Cartridge Low** appears, order a new print cartridge.

### THE PRINT CARTRIDGE MAY BE DEFECTIVE

Replace the print cartridge.

## Print is too dark



These are possible solutions. Try one or more of the following:

### **CHECK THE DARKNESS, BRIGHTNESS, AND CONTRAST SETTINGS**

The Toner Darkness setting is too dark, the Brightness setting is too dark, or the Contrast setting is too high.

- From the printer control panel, change these settings from the Quality menu.
- For Windows users, change these settings from Print Properties.
- For Macintosh users, change these settings from the Print dialog and pop-up menus.

### **THE PAPER HAS ABSORBED MOISTURE DUE TO HIGH HUMIDITY**

- Load paper from a fresh package.
- Store paper in its original wrapper until you use it.

### **CHECK THE PAPER**

Avoid textured paper with rough finishes.

### **CHECK THE PAPER TYPE SETTING**

Make sure the paper type setting matches the paper loaded in the tray:

- 1** From the printer control panel, check the Paper Type setting from the Paper menu.
- 2** Before sending the job to print, specify the correct type setting:
  - For Windows users, specify the type from Print Properties.
  - For Macintosh users, specify the type from the Print dialog.

### **THE PRINT CARTRIDGE MAY BE DEFECTIVE**

Replace the print cartridge.



## Solid color pages

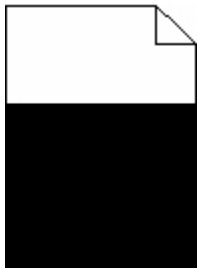

These are possible solutions. Try one or more of the following:

### **MAKE SURE THE PRINT CARTRIDGE IS PROPERLY INSTALLED**

Remove the print cartridge and shake it from side to side to redistribute the toner, and then reinstall it.

### **THE PRINT CARTRIDGE MAY BE DEFECTIVE OR LOW ON TONER**

Replace the used print cartridge with a new one. If the problem continues, the printer may need to be serviced. For more information, contact Customer Support.

## Streaked vertical lines



These are possible solutions. Try one or more of the following:

### **THE TONER IS SMEARED**

Select another tray or feeder to feed paper for the job:

- From the printer control panel, select the Default Source from the Paper Menu.
- For Windows users, select the paper source from Print Properties.
- For Macintosh users, select the paper source from the Print dialog and pop-up menus.

### **THE PRINT CARTRIDGE IS DEFECTIVE**

Replace the print cartridge.

### **THE PAPER PATH MAY NOT BE CLEAR**

Check the paper path around the print cartridge.



**CAUTION—HOT SURFACE:** The inside of the printer might be hot. To reduce the risk of injury from a hot component, allow the surface to cool before touching.

Clear any paper you see.

## **THERE IS TONER IN THE PAPER PATH**

Contact Customer Support.

## **Toner fog or background shading appears on the page**

These are possible solutions. Try one or more of the following:

### **THE PRINT CARTRIDGE MAY BE DEFECTIVE**

Replace the print cartridge.

### **THE CHARGE ROLLS MAY BE DEFECTIVE**

Replace the charge rolls.

## **THERE IS TONER IN THE PAPER PATH**

Contact Customer Support.

## **Toner rubs off**

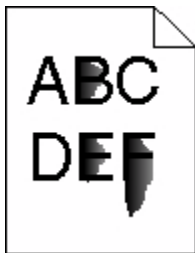

These are possible solutions. Try one or more of the following:

### **CHECK THE PAPER TYPE SETTING**

Make sure the paper type setting matches the paper loaded in the tray:

- 1** From the printer control panel, check the Paper Type setting from the Paper menu.
- 2** Before sending the job to print, specify the correct type setting:
  - For Windows users, specify the type from Print Properties.
  - For Macintosh users, specify the type from the Print dialog.

### **CHECK THE PAPER TEXTURE SETTING**

From the printer control panel Paper menu, make sure the Paper Texture setting matches the paper loaded in the tray.

## Toner specks

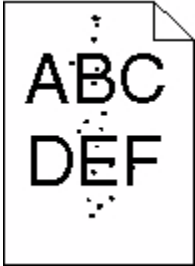

These are possible solutions. Try one or more of the following:

### **THE PRINT CARTRIDGE MAY BE DEFECTIVE**

Replace the print cartridge.

### **THERE IS TONER IN THE PAPER PATH**

Contact Customer Support.

## Transparency print quality is poor

Try one or more of the following:

### **CHECK THE TRANSPARENCIES**

Use only transparencies recommended by the printer manufacturer.

### **CHECK THE PAPER TYPE SETTING**

Make sure the paper type setting matches the paper loaded in the tray:

- 1 From the printer control panel, check the Paper Type setting from the Paper menu.
- 2 Before sending the job to print, specify the correct type setting:
  - For Windows users, specify the type from Print Properties.
  - For Macintosh users, specify the type from the Print dialog.

## Embedded Web Server does not open

These are possible solutions. Try one or more of the following:

### **CHECK THE NETWORK CONNECTIONS**

Make sure the printer and computer are turned on and connected to the same network.

## **CHECK THE NETWORK SETTINGS**

Depending on the network settings, you may need to type `https://` instead of `http://` before the printer IP address to access the Embedded Web Server. For more information, see your system administrator.

## **Contacting Customer Support**

When you call Customer Support, describe the problem you are experiencing, the message on the display, and the troubleshooting steps you have already taken to find a solution.

You need to know your printer model type and serial number. For more information, see the label on the inside top front cover of the printer. The serial number is also listed on the menu settings page.

For customer support, contact the place where you purchased your printer.

# Notices

Product name:

Monochrome Laser MFP

Machine type:

4548, 4566, 4567, 4568, 5535, 7462

Model(s):

aa1, aa2, bb1, bb2, bd1, bd2, b01, b02, cc1, cc2, dn, dn1, dn2, dt1, dt2, f01, f02, fd1, fd2, g01, g02, g61, g62, g71, g72, g81, g82, g91, g92, gb1, gb2, gf1, gf2, gn1, gn2, gs1, gs2, gt1, gt2, mn1, n01, n02, s01, s02, sd1, sd2, t01, t02, tb1, tb2, tf1, tf2, ts1, ts2, 0A1, 0A5, 031, 035, 2A1, 2A2, 2A5, 2A6, 231, 232, 235, 236, 4A2, 4A6, 432, 436

## Edition notice

October 2009

**The following paragraph does not apply to any country where such provisions are inconsistent with local law:** LEXMARK INTERNATIONAL, INC., PROVIDES THIS PUBLICATION "AS IS" WITHOUT WARRANTY OF ANY KIND, EITHER EXPRESS OR IMPLIED, INCLUDING, BUT NOT LIMITED TO, THE IMPLIED WARRANTIES OF MERCHANTABILITY OR FITNESS FOR A PARTICULAR PURPOSE. Some states do not allow disclaimer of express or implied warranties in certain transactions; therefore, this statement may not apply to you.

This publication could include technical inaccuracies or typographical errors. Changes are periodically made to the information herein; these changes will be incorporated in later editions. Improvements or changes in the products or the programs described may be made at any time.

## UNITED STATES GOVERNMENT RIGHTS

This software and any accompanying documentation provided under this agreement are commercial computer software and documentation developed exclusively at private expense.

## Federal Communications Commission (FCC) compliance information statement

This product has been tested and found to comply with the limits for a Class A digital device, pursuant to Part 15 of the FCC Rules. Operation is subject to the following two conditions: (1) this device may not cause harmful interference, and (2) this device must accept any interference received, including interference that may cause undesired operation.

The FCC Class A limits are designed to provide reasonable protection against harmful interference when the equipment is operated in a commercial environment. This equipment generates, uses, and can radiate radio frequency energy and, if not installed and used in accordance with the instruction manual, may cause harmful interference to radio communications. Operation of this equipment in a residential area is likely to cause harmful interference, in which case the user will be required to correct the interference at his own expense.

The manufacturer is not responsible for any radio or television interference caused by using other than recommended cables or by unauthorized changes or modifications to this equipment. Unauthorized changes or modifications could void the user's authority to operate this equipment.

**Note:** To assure compliance with FCC regulations on electromagnetic interference for a Class A computing device, use a properly shielded and grounded cable such as Lexmark part number 1021231 for parallel attach or 1021294 for USB attach. Use of a substitute cable not properly shielded and grounded may result in a violation of FCC regulations.

## Compliance statement

This product complies with the Class A emission requirements of EN55022 and immunity requirements of EN55024. This product is not intended to be used in residential environments.

## Exposure to radio frequency radiation

The following notice is applicable if your printer has a wireless network card installed.

The radiated output power of this device is far below the FCC radio frequency exposure limits. A minimum separation of 20 cm (8 inches) must be maintained between the antenna and any persons for this device to satisfy the RF exposure requirements of the FCC.

## Industry Canada notices

### Industry Canada compliance statement

This Class A digital apparatus meets all requirements of the Canadian Interference-Causing Equipment Standard ICES-003.

### Avis de conformité aux normes de l'industrie du Canada

Cet appareil numérique de classe A est conforme aux exigences de la norme canadienne relative aux équipements pouvant causer des interférences NMB-003.

### Industry Canada radio interference statement

#### Industry Canada (Canada)

This device complies with Industry Canada specification RSS-210. Operation is subject to the following two conditions: (1) this device may not cause interference, and (2) this device must accept any interference, including interference that may cause undesired operation of the device.

This device has been designed to operate only with the antenna provided. Use of any other antenna is strictly prohibited per regulations of Industry Canada.

To prevent radio interference to the licensed service, this device is intended to be operated indoors and away from windows to provide maximum shielding. Equipment (or its transmit antenna) that is installed outdoors is subject to licensing.

The installer of this radio equipment must ensure that the antenna is located or pointed such that it does not emit RF fields in excess of Health Canada limits for the general population; consult Safety Code 6, obtainable from Health Canada's Web site [www.hc-sc.gc.ca/rpb](http://www.hc-sc.gc.ca/rpb).

The term "IC:" before the certification/registration number only signifies that the Industry Canada technical specifications were met.

### **Industry Canada (Canada)**

Cet appareil est conforme à la norme RSS-210 d'Industry Canada. Son fonctionnement est soumis aux deux conditions suivantes :

(1) cet appareil ne doit pas provoquer d'interférences et (2) il doit accepter toute interférence reçue, y compris celles risquant d'altérer son fonctionnement.

Cet appareil a été conçu pour fonctionner uniquement avec l'antenne fournie. L'utilisation de toute autre antenne est strictement interdite par la réglementation d'Industry Canada.

En application des réglementations d'Industry Canada, l'utilisation d'une antenne de gain supérieur est strictement interdite.

Pour empêcher toute interférence radio au service faisant l'objet d'une licence, cet appareil doit être utilisé à l'intérieur et loin des fenêtres afin de garantir une protection optimale.

Si le matériel (ou son antenne d'émission) est installé à l'extérieur, il doit faire l'objet d'une licence.

L'installateur de cet équipement radio doit veiller à ce que l'antenne soit implantée et dirigée de manière à n'émettre aucun champ HF dépassant les limites fixées pour l'ensemble de la population par Santé Canada. Reportez-vous au Code de sécurité 6 que vous pouvez consulter sur le site Web de Santé Canada [www.hc-sc.gc.ca/rpb](http://www.hc-sc.gc.ca/rpb).

Le terme « IC » précédant le numéro de d'accréditation/inscription signifie simplement que le produit est conforme aux spécifications techniques d'Industry Canada.

## **Radio interference notice**

This is a Class A product. In a domestic environment, this product may cause radio interference, in which case, the user may be required to take adequate measures.

## **European Community (EC) directives conformity**

This product is in conformity with the protection requirements of EC Council directives 2004/108/EC, 2006/95/EC, and 1999/5/EC on the approximation and harmonization of the laws of the Member States relating to electromagnetic compatibility, safety of electrical equipment designed for use within certain voltage limits and on radio equipment and telecommunications terminal equipment.

Compliance is indicated by the CE marking.



A declaration of conformity with the requirements of the directives is available from the Director of Manufacturing and Technical Support, Lexmark International, S. A., Boigny, France.

This product satisfies the limits of EN 55022; safety requirements of EN 60950; radio spectrum requirements of ETSI EN 300 330-1 and ETSI EN 300 330-2; and the EMC requirements of EN 55024, ETSI EN 301 489-1 and ETSI EN 301 489-3.

Česky	Společnost Lexmark International, Inc. tímto prohlašuje, že výrobek tento výrobek je ve shodě se základními požadavky a dalšími příslušnými ustanoveními směrnice 1999/5/ES.
Dansk	Lexmark International, Inc. erklærer herved, at dette produkt overholder de væsentlige krav og øvrige relevante krav i direktiv 1999/5/EF.
Deutsch	Hiermit erklärt Lexmark International, Inc., dass sich das Gerät dieses Gerät in Übereinstimmung mit den grundlegenden Anforderungen und den übrigen einschlägigen Bestimmungen der Richtlinie 1999/5/EG befindet.
Ελληνική	ΜΕ ΤΗΝ ΠΑΡΟΥΣΑ Η LEXMARK INTERNATIONAL, INC. ΔΗΛΩΝΕΙ ΟΤΙ ΑΥΤΟ ΤΟ ΠΡΟΪΟΝ ΣΥΜΜΟΡΦΩΝΕΤΑΙ ΠΡΟΣ ΤΙΣ ΟΥΣΙΩΔΕΙΣ ΑΠΑΙΤΗΣΕΙΣ ΚΑΙ ΤΙΣ ΛΟΙΠΕΣ ΣΧΕΤΙΚΕΣ ΔΙΑΤΑΞΕΙΣ ΤΗΣ ΟΔΗΓΙΑΣ 1999/5/ΕΚ.
English	Hereby, Lexmark International, Inc., declares that this type of equipment is in compliance with the essential requirements and other relevant provisions of Directive 1999/5/EC.
Español	Por medio de la presente, Lexmark International, Inc. declara que este producto cumple con los requisitos esenciales y cualesquiera otras disposiciones aplicables o exigibles de la Directiva 1999/5/CE.
Eesti	Käesolevaga kinnitab Lexmark International, Inc., et seade see toode vastab direktiivi 1999/5/EÜ põhinõuetele ja nimetatud direktiivist tulenevatele muudele asjakohastele sätetele.
Suomi	Lexmark International, Inc. vakuuttaa täten, että tämä tuote on direktiivin 1999/5/EY oleellisten vaatimusten ja muiden sitä koskevien direktiivin ehtojen mukainen.
Français	Par la présente, Lexmark International, Inc. déclare que l'appareil ce produit est conforme aux exigences fondamentales et autres dispositions pertinentes de la directive 1999/5/CE.
Magyar	Alulírott, Lexmark International, Inc. nyilatkozom, hogy a termék megfelel a vonatkozó alapvető követelményeknek és az 1999/5/EC irányelv egyéb előírásainak.
Íslenska	Hér með lýsir Lexmark International, Inc. yfir því að þessi vara er í samræmi við grunnkröfur og aðrar kröfur, sem gerðar eru í tilskipun 1999/5/EC.
Italiano	Con la presente Lexmark International, Inc. dichiara che questo prodotto è conforme ai requisiti essenziali ed alle altre disposizioni pertinenti stabilite dalla direttiva 1999/5/CE.
Latviski	Ar šo Lexmark International, Inc. deklarē, ka šis izstrādājums atbilst Direktīvas 1999/5/EK būtiskajām prasībām un citiem ar to saistītajiem noteikumiem.
Lietuvių	Šiuo Lexmark International, Inc. deklaruoja, kad šis produktas atitinka esminius reikalavimus ir kitas 1999/5/EB direktyvos nuostatas.
Malti	Bil-preżenti, Lexmark International, Inc., jiddikjara li dan il-prodott huwa konformi mal-ħtiġijiet essenzjali u ma dispozizzjonijiet oħrajn relevanti li jinsabu fid-Direttiva 1999/5/KE.
Nederlands	Hierbij verklaart Lexmark International, Inc. dat het toestel dit product in overeenstemming is met de essentiële eisen en de andere relevante bepalingen van richtlijn 1999/5/EG.
Norsk	Lexmark International, Inc. erklærer herved at dette produktet er i samsvar med de grunnleggende krav og øvrige relevante krav i direktiv 1999/5/EF.
Polski	Niniejszym Lexmark International, Inc. oświadcza, że niniejszy produkt jest zgodny z zasadniczymi wymogami oraz pozostałymi stosownymi postanowieniami Dyrektywy 1999/5/EC.
Português	A Lexmark International Inc. declara que este este produto está conforme com os requisitos essenciais e outras disposições da Diretiva 1999/5/CE.



Slovensky	Lexmark International, Inc. týmto vyhlasuje, že tento produkt spĺňa základné požiadavky a všetky príslušné ustanovenia smernice 1999/5/ES.
Slovensko	Lexmark International, Inc. izjavlja, da je ta izdelek v skladu z bistvenimi zahtevami in ostalimi relevantnimi določili direktive 1999/5/ES.
Svenska	Härmed intygar Lexmark International, Inc. att denna produkt står i överensstämmelse med de väsentliga egenskapskrav och övriga relevanta bestämmelser som framgår av direktiv 1999/5/EG.

## India emissions notice

This device uses very low power low range RF communication that has been tested and found not to cause any interference whatsoever. The manufacturer is not responsible in case of any disputes arising out of requirement of permissions from any local authority, regulatory bodies or any organization, required by the end-user to install and operate this product at his premises.

### भारतीय उत्सर्जन सूचना

यह यंत्र बहुत ही कम शक्ति, कम रेंज के RF कम्युनिकेशन का प्रयोग करता है जिसका परीक्षण किया जा चुका है, और यह पाया गया है कि यह किसी भी प्रकार का व्यवधान उत्पन्न नहीं करता। इसके अंतिम प्रयोगता द्वारा इस उत्पाद को अपने प्रांगण में स्थापित एवं संचालित करने हेतु किसी स्थानीय प्राधिकरण, नियामक निकायों या किसी संगठन से अनुज्ञा प्राप्त करने की जरूरत के संबंध में उठे विवाद की स्थिति में विनिर्माता जिम्मेदार नहीं है।

## Noise emission levels

The following measurements were made in accordance with ISO 7779 and reported in conformance with ISO 9296.

**Note:** Some modes may not apply to your product.

1-meter average sound pressure, dBA	
Printing	56 dBA
Scanning	52 dBA
Copying	56 dBA
Ready	30 dBA

## Temperature information

Ambient temperature	15.6°C – 32.2°C
Shipping and storage temperature	-40.0°C – 60.0°C

## Product disposal

Do not dispose of the printer or supplies in the same manner as normal household waste. Consult your local authorities for disposal and recycling options.

# Federal Communications Commission (FCC) compliance information statement

This equipment complies with Part 68 of the FCC rules and the requirements adopted by the Administrative Council for Terminal Attachments (ACTA). On the back of this equipment is a label that contains, among other information, a product identifier in the format US:AAAEQ##TXXXX. If requested, this number must be provided to your telephone company.

This equipment uses the RJ-11C Universal Service Order Code (USOC) jack.

A plug and jack used to connect this equipment to the premises' wiring and telephone network must comply with the applicable FCC Part 68 rules and requirements adopted by the ACTA. A compliant telephone cord and modular plug is provided with this product. It is designed to be connected to a compatible modular jack that is also compliant. See your setup documentation for more information.

The Ringer Equivalence Number (REN) is used to determine the number of devices that may be connected to a telephone line. Excessive RENs on a telephone line may result in the devices not ringing in response to an incoming call. In most but not all areas, the sum of RENs should not exceed five (5.0). To be certain of the number of devices that may be connected to a line, as determined by the total RENs, contact your local telephone company. For products approved after July 23, 2001, the REN for this product is part of the product identifier that has the format US:AAAEQ##TXXXX. The digits represented by ## are the REN without a decimal point (for example, 03 is a REN of 0.3). For earlier products, the REN is shown separately on the label.

If this equipment causes harm to the telephone network, the telephone company will notify you in advance that temporary discontinuance of service may be required. If advance notice is not practical, the telephone company will notify the customer as soon as possible. You will also be advised of your right to file a complaint with the FCC.

The telephone company may make changes in its facilities, equipment, operations or procedures that could affect the operation of this equipment. If this happens, the telephone company will provide advance notice in order for you to make necessary modifications to maintain uninterrupted service.

If you experience trouble with this equipment, for repair or warranty information, contact your point of purchase. If the equipment is causing harm to the telephone network, the telephone company may request that you disconnect the equipment until the problem is resolved.

This equipment contains no user serviceable parts. For repair and warranty information, contact your point of purchase.

Connection to party line service is subject to state tariffs. Contact the state public utility commission, public service commission, or corporation commission for information.

If your home has specially wired alarm equipment connected to the telephone line, ensure the installation of this equipment does not disable your alarm equipment. If you have questions about what will disable alarm equipment, consult your telephone company or a qualified installer.

Telephone companies report that electrical surges, typically lightning transients, are very destructive to customer terminal equipment connected to AC power sources. This has been identified as a major nationwide problem. It is recommended that the customer install an appropriate AC surge arrester in the AC outlet to which this device is connected. An appropriate AC surge arrester is defined as one that is suitably rated, and certified by UL (Underwriter's Laboratories), another NRTL (Nationally Recognized Testing Laboratory), or a recognized safety certification body in the country/region of use. This is to avoid damage to the equipment caused by local lightning strikes and other electrical surges.

The Telephone Consumer Protection Act of 1991 makes it unlawful for any person to use a computer or other electronic device, including fax machines, to send any message unless said message clearly contains in a margin at the top or bottom of each transmitted page or on the first page of the transmission, the date and time it is sent and

an identification of the business or other entity, or other individual sending the message, and the telephone number of the sending machine or such business, other entity, or individual. (The telephone number provided may not be a 900 number or any other number for which charges exceed local or long-distance transmission charges.)

See your user documentation in order to program this information into your fax machine.

## **Notice to users of the Canadian telephone network**

This product meets the applicable Industry Canada technical specifications. The Ringer Equivalence Number (REN) is an indication of the maximum number of terminals allowed to be connected to a telephone interface. The terminus of an interface may consist of any combination of devices, subject only to the requirement that the sum of the RENs of all the devices does not exceed five. The modem REN is located on the rear of the equipment on the product labeling.

Telephone companies report that electrical surges, typically lightning transients, are very destructive to customer terminal equipment connected to AC power sources. This has been identified as a major nationwide problem. It is recommended that the customer install an appropriate AC surge arrestor in the AC outlet to which this device is connected. An appropriate AC surge arrestor is defined as one that is suitably rated, and certified by UL (Underwriter's Laboratories), another NRTL (Nationally Recognized Testing Laboratory), or a recognized safety certification body in the country/region of use. This is to avoid damage to the equipment caused by local lightning strikes and other electrical surges.

This equipment uses CA11A telephone jacks.

## **Avis réservé aux utilisateurs du réseau téléphonique du Canada**

Ce produit est conforme aux spécifications techniques d'Industrie Canada. Le numéro REN (ringer equivalence number : numéro d'équivalence de sonnerie) fournit une indication du nombre maximum de terminaux pouvant être connectés à l'interface téléphonique. En bout de ligne, le nombre d'appareils qui peuvent être connectés n'est pas directement limité, mais la somme des REN de ces appareils ne doit pas dépasser cinq. Le numéro REN du modem est indiqué sur l'étiquette produit située à l'arrière de l'équipement.

Les compagnies de téléphone constatent que les surtensions électriques, en particulier celles dues à la foudre, entraînent d'importants dégâts sur les terminaux privés connectés à des sources d'alimentation CA. Il s'agit-là d'un problème majeur d'échelle nationale. En conséquence, il vous est recommandé de brancher un parasurtenseur dans la prise de courant à laquelle l'équipement est connecté. Utilisez un parasurtenseur répondant à des caractéristiques nominales satisfaisantes et certifié par le laboratoire d'assureurs UL (Underwriter's Laboratories), un autre laboratoire agréé de type NRTL (Nationally Recognized Testing Laboratory) ou un organisme de certification agréé dans votre région ou pays. Ceci prévient tout endommagement de l'équipement causé par les orages et autres surtensions électriques.

Cet équipement utilise des prises de téléphone CA11A.

## **Notice to users of the New Zealand telephone network**

The following are special conditions for the Facsimile User Instructions. The grant of a telepermit for any item of terminal equipment indicates only that Telecom has accepted that the item complies with minimum conditions for connection to its network. It indicates no endorsement of the product by Telecom, nor does it provide any sort of warranty. Above all, it provides no assurance that any item will work correctly in all respects with another item of telepermitted equipment of a different make or model, nor does it imply that any product is compatible with all of Telecom's network services.

This equipment shall not be set up to make automatic calls to the Telecom's 111 Emergency Service.

This equipment may not provide for the effective hand-over of a call to another device connected to the same line. This equipment should not be used under any circumstances that may constitute a nuisance to other Telecom customers.

Some parameters required for compliance with Telecom's telepermit requirements are dependent on the equipment associated with this device. The associated equipment shall be set to operate within the following limits for compliance to Telecom's specifications:

- There shall be no more than 10 call attempts to the same number within any 30 minute period for any single manual call initiation, and
- The equipment shall go on-hook for a period of not less than 30 seconds between the end of one attempt and the beginning of the next call attempt.
- The equipment shall be set to ensure that automatic calls to different numbers are spaced such that there is not less than 5 seconds between the end of one call attempt and the beginning of another.

## **South Africa telecommunications notice**

This modem must be used in conjunction with an approved surge protection device when connected to the PSTN.

## **Using this product in Switzerland**

This product requires a Swiss billing tone filter to be installed on any line which receives metering pulses in Switzerland. The Lexmark filter must be used, as metering pulses are present on all analog telephone lines in Switzerland.

## **Utilisation de ce produit en Suisse**

Cet appareil nécessite l'utilisation d'un filtre de tonalité de facturation suisse devant être installé sur toute ligne recevant des impulsions de comptage en Suisse. Ce filtre doit être installé car les impulsions de comptage sont utilisées sur toutes les lignes téléphoniques analogiques en Suisse.

## **Verwendung dieses Produkts in der Schweiz**

Für dieses Produkt muss ein Schweizer Billing Tone Filter (zur Zählzeichenübertragung) für jede Leitung installiert werden, über die in der Schweiz Zeitsteuertakte übertragen werden. Die Verwendung des Billing Tone Filters ist obligatorisch, da in allen analogen Telefonleitungen in der Schweiz Zeitsteuertakte vorhanden sind.

## **Uso del prodotto in Svizzera**

Per questo prodotto è necessario un filtro toni Billing svizzero, da installare su tutte le linee che ricevono impulsi remoti in Svizzera. È necessario utilizzare il filtro toni Billing dal momento che gli impulsi remoti sono presenti su tutte le linee telefoniche in Svizzera.

# ENERGY STAR



## Laser notice

The printer is certified in the U.S. to conform to the requirements of DHHS 21 CFR Subchapter J for Class I (1) laser products, and elsewhere is certified as a Class I laser product conforming to the requirements of IEC 60825-1.

Class I laser products are not considered to be hazardous. The printer contains internally a Class IIIb (3b) laser that is nominally a 5 milliwatt gallium arsenide laser operating in the wavelength of 770-795 nanometers. The laser system and printer are designed so there is never any human access to laser radiation above a Class I level during normal operation, user maintenance, or prescribed service condition.

## Laser advisory label

A laser notice label may be affixed to this printer as shown:



## Power consumption

### Product power consumption

The following table documents the power consumption characteristics of the product.

**Note:** Some modes may not apply to your product.

Mode	Description	Power consumption (Watts)
Printing	The product is generating hard-copy output from electronic inputs.	700 W
Copying	The product is generating hard-copy output from hard-copy original documents.	765 W
Scanning	The product is scanning hard-copy documents.	165 W
Ready	The product is waiting for a print job.	95 W
Power Saver	The product is in energy-saving mode.	21 W
Off	The product is plugged into a wall outlet, but the power switch is turned off.	110V = 0.15W, 220V = 1.25W

The power consumption levels listed in the previous table represent time-averaged measurements. Instantaneous power draws may be substantially higher than the average.

## Power Saver

This product is designed with an energy-saving mode called Power Saver. The Power Saver Mode is equivalent to the EPA Sleep Mode. The Power Saver Mode saves energy by lowering power consumption during extended periods of inactivity. The Power Saver Mode is automatically engaged after this product is not used for a specified period of time, called the Power Saver Timeout.

Factory default Power Saver Timeout for this product (in minutes):	110V = 45 minutes, 220V = 60 minutes
--	--------------------------------------

By using the configuration menus, the Power Saver Timeout can be modified between 1 minute and 240 minutes. Setting the Power Saver Timeout to a low value reduces energy consumption, but may increase the response time of the product. Setting the Power Saver Timeout to a high value maintains a fast response, but uses more energy.

## Off mode

If this product has an off mode which still consumes a small amount of power, then to completely stop product power consumption, disconnect the power supply cord from the wall outlet.

## Total energy usage

It is sometimes helpful to calculate the total product energy usage. Since power consumption claims are provided in power units of Watts, the power consumption should be multiplied by the time the product spends in each mode in order to calculate energy usage. The total product energy usage is the sum of each mode's energy usage.

# Index

## Numerics

- 1565 Emulation error, load emulation option 247
- 2000-sheet tray
  - loading 74
- 200–282.yy paper jam 245
- 250-sheet tray (standard or optional)
  - loading 71
- 283 Staple jam 245
- 290-294.yy scanner jam 245
- 293 Replace all originals if restarting job 245
- 293.02 Flatbed Cover Open 246
- 30 Invalid refill, change cartridge 238
- 31 Replace defective cartridge 238
- 32 Cartridge part number unsupported by device 238
- 34 Short paper 239
- 35 Insufficient memory to support Resource Save feature 239
- 37 Insufficient memory for Flash Memory Defragment operation 239
- 37 Insufficient memory to collate job 239
- 37 Insufficient memory, some Held Jobs were deleted 239
- 37 Insufficient memory, some held jobs will not be restored 239
- 38 Memory full 240
- 39 Complex page, some data may not have printed 240
- 42.xy Cartridge region mismatch 240
- 50 PPDS font error 240
- 51 Defective flash detected 240
- 52 Not enough free space in flash memory for resources 241
- 53 Unformatted flash detected 241
- 54 Network <x> software error 241
- 54 Serial option <x> error 241
- 54 Standard network software error 241
- 55 Unsupported option in slot 242

- 550-sheet tray (standard or optional)
  - loading 71
- 56 Parallel port <x> disabled 242
- 56 Serial port <x> disabled 242
- 56 Standard parallel port disabled 242
- 56 Standard USB port disabled 242
- 56 USB port <x> disabled 243
- 57 Configuration change, held jobs were not restored 243
- 58 Too many bins attached 243
- 58 Too many disks installed 243
- 58 Too many flash options installed 243
- 58 Too many trays attached 244
- 59 Incompatible envelope feeder 244
- 59 Incompatible output bin <x> 244
- 59 Incompatible tray <x> 244
- 61 Remove defective disk 244
- 62 Disk full 244
- 63 Unformatted disk 245
- 80 Routine maintenance needed 245
- 840.01 Scanner Disabled 246
- 841-846 Scanner Service Error 246
- 88 Cartridge low 245
- 88.yy Cartridge nearly low 245
- 88.yy Replace cartridge 245
- 900–999 Service <message> 246

## Symbols

- “scan to computer” screen options 126, 127, 128

## A

- Active NIC menu 164
- address book, fax
  - using 113
- ADF
  - copying using 91
- Answering 229
- AppleTalk menu 170
- attaching cables 43

## B

- Bin Setup menu 161
- brightness, adjusting 255
- Busy 229
- buttons, home screen 18
- buttons, printer control panel 17
- buttons, touch screen 20

## C

- cables
  - Ethernet 43
  - USB 43
- Call complete 229
- calling Customer Support 284
- canceling a job
  - from Macintosh 136
  - from the printer control panel 135
  - from Windows 136
- card stock
  - loading 78
  - tips on using 131
- Change <src> to <x> 229
- Check tray <x> connection 229
- checking an unresponsive printer 257
- checking an unresponsive scanner 263
- checking device status
  - on Embedded Web Server 254
- cleaning
  - exterior of the printer 248
  - scanner glass 248
- Close door or insert cartridge 230
- Close finisher side door 230
- collating copies 96
- Confidential print jobs 132
  - printing from Macintosh computer 133
  - printing from Windows 132
- Confidential Print menu 178
- configuration information
  - wireless network 47
- configurations
  - printer 14
- Configure MP menu 154
- configuring
  - port settings 55

- configuring the e-mail settings 105
  - Connect <x>bps 230
  - connecting fax
    - using RJ11 adapter 60
  - connecting the printer to
    - answering machine 65
    - computer modem 67
    - telephone 64
    - telephone wall jack in Germany 63
  - conserving supplies 251
  - contacting Customer Support 284
  - control panel, printer 17
  - copy quality
    - adjusting 96
    - improving 103
  - copy screen
    - options 100, 101, 102
  - Copy Settings menu 189
  - copy troubleshooting
    - copier does not respond 261
    - partial document or photo copies 263
    - poor copy quality 261
    - poor scanned image quality 264
    - scanner unit does not close 261
  - copying
    - adding a date and time stamp 99
    - adding an overlay message 99
    - adjusting quality 96
    - canceling a copy job 100
    - collating copies 96
    - custom job (job build) 98
    - document containing mixed paper sizes 94
    - enlarging 95
    - from one size to another 93
    - improving copy quality 103
    - making transparencies 92
    - multiple pages on one sheet 97
    - on both sides of the paper (duplexing) 95
    - photos 92
    - placing separator sheets between copies 97
    - quick copy 91
    - reducing 95
    - selecting a tray 94
    - to letterhead 93
    - using the ADF 91
    - using the scanner glass (flatbed) 92
  - Custom Bin Names menu 160
  - Custom Names menu 160
  - custom paper type
    - assigning 82
  - Custom Scan Sizes menu 160
  - Custom Type <x>
    - changing name 82
  - Custom Types menu 159
- D**
- date and time
    - setting 68
  - Default Source menu 151
  - Dialing 230
  - directory list, printing 135
  - Disk corrupted 230
  - Disk Full - Scan Job Canceled 230
  - Disk Wiping menu 179
  - display troubleshooting
    - display is blank 257
    - display shows only diamonds 257
  - display, printer control panel 17
    - adjusting brightness 255
  - documents, printing
    - from Macintosh 129
    - from Windows 129
  - duplexing 95
- E**
- Embedded Web Server 254
    - checking device status 254
    - does not open 283
    - setting up e-mail alerts 254
  - emission
    - notices 285, 286, 287, 288, 289
  - enlarging a copy 95
  - Envelope Enhance 155
  - envelopes
    - loading 78, 80
    - tips on using 130
  - Ethernet networking
    - Macintosh 52
    - Windows 52
  - Ethernet port 43
  - exterior of the printer
    - cleaning 248
  - e-mail
    - canceling 108
    - notice of low supply level 254
    - notice of paper jam 254
    - notice of paper needed 254
    - notice that different paper is needed 254
  - e-mail function
    - setting up 104
  - e-mail screen
    - advanced options 109
    - options 108, 109
  - E-mail Settings menu 203
  - e-mailing
    - adding message line 107
    - adding subject line 107
    - changing output file type 107
    - configuring the e-mail settings 105
    - creating shortcuts using the Embedded Web Server 105
    - creating shortcuts using the touch screen 105
    - setting up e-mail function 104
    - using shortcut numbers 106
    - using the address book 106
    - using the touch screen 106
- F**
- factory defaults, restoring
    - printer control panel menus 256
  - fax card
    - installing 41
  - Fax failed 230
  - Fax memory full 231
  - Fax Mode (Analog Fax Setup) menu 194
  - Fax Mode (Fax Server Setup) menu 202
  - Fax partition inoperative. Contact system administrator. 231
  - fax quality, improving 118
  - fax screen
    - advanced options 117
    - options 116, 117
  - Fax server 'To Format' not set up. Contact system administrator. 231
  - Fax Station Name not set up 231
  - Fax Station Number not set up 231
  - fax troubleshooting
    - blocking junk faxes 115
    - caller ID is not shown 265
    - can receive but not send faxes 268



- can send but not receive
  - faxes 267
- cannot send or receive a fax 265
- received fax has poor print
  - quality 268
- faxing
  - canceling a fax job 116
  - changing resolution 114
  - choosing a fax connection 59
  - creating shortcuts using the
    - Embedded Web Server 112
  - creating shortcuts using the touch
    - screen 113
  - forwarding faxes 119
  - holding faxes 118
  - improving fax quality 118
  - making a fax lighter or
    - darker 114
  - sending a fax at a scheduled
    - time 115
  - sending using the computer 112
  - sending using the printer control
    - panel 111
  - setting the date and time 68
  - setting the outgoing fax name and
    - number 68
  - turning Daylight Saving Time
    - on 69
  - using shortcuts 113
  - using the address book 113
  - viewing a fax log 115
- FCC notices 285, 286, 290
- fiber optic
  - network setup 52
- Finishing menu 218
- firmware card
  - installing 28
- flash drive 134
- Flash Drive menu 211
- flash memory card
  - installing 28
  - troubleshooting 271
- Flushing buffer 231
- forwarding faxes 119
- FTP
  - address book 121
- FTP quality, improving 124
- FTP screen
  - advanced options 123
  - options 122, 123
- FTP Settings menu 208

## G

- guidelines
  - card stock 131
  - envelopes 130
  - labels 131
  - letterhead 129
  - transparencies 130

## H

- hard disk with adapter
  - troubleshooting 271
- held jobs 132
  - printing from Macintosh
    - computer 133
  - printing from Windows 132
- Help menu 228
- holding faxes 118
- home screen
  - buttons 18
- HTML menu 226

## I

- Image menu 227
- Insert staple cartridge 231
- Insert Tray <x> 232
- Install bin <x> 232
- Install envelope feeder 232
- Install tray <x> 232
- installation
  - wireless network 47, 49
- installing
  - options in driver 46
  - printer software 45
- installing printer software
  - adding options 46
- Internal Solutions Port
  - installing 31
  - troubleshooting 271
- Internal Solutions Port, network
  - changing port settings 55
- Invalid PIN 232
- IPv6 menu 169

## J

- jams
  - avoiding 138
  - locating doors and trays 139
  - locations 139
  - numbers 139

- jams, clearing
  - 200 139
  - 201 139
  - 202 141
  - 230–239 142
  - 240–249 143
  - 250 144
  - 260 145
  - 270–279 145
  - 280–282 paper jams 145
  - 283 staple jams 146
  - 290–294 148
  - stapler 146
- job interrupt 99
- Job stored for delayed
  - transmission 233

## L

- labels
  - tips on using 131
- letterhead
  - copying to 93
  - loading, 2000-sheet tray 74
  - loading, multipurpose feeder 78
  - loading, trays 71
  - tips on using 129
- LexLink menu 171
- light, indicator 17
- Line busy 233
- linking trays 81
- Load <src> with <x> 233
- Load manual feeder with <x> 233
- Load staples 233
- loading
  - 2000-sheet tray 74
  - 250-sheet tray (standard or
    - optional) 71
  - 550-sheet tray (standard or
    - optional) 71
  - card stock 78
  - envelopes 78, 80
  - letterhead in 2000-sheet tray 74
  - letterhead in multipurpose
    - feeder 78
  - letterhead in trays 71
  - multipurpose feeder 78
  - transparencies 78

## M

- Macintosh
  - wireless network installation 49

- memory card
  - installing 27
  - troubleshooting 271
- Memory full, cannot print
- faxes 233
- menu settings page
  - printing 44
- menus
  - Active NIC 164
  - AppleTalk 170
  - Bin Setup 161
  - Confidential Print 178
  - Configure MP 154
  - Copy Settings 189
  - Custom Bin Names 160
  - Custom Names 160
  - Custom Scan Sizes 160
  - Custom Types 159
  - Default Source 151
  - diagram of 150
  - Disk Wiping 179
  - Envelope Enhance 155
  - E-mail Settings 203
  - Fax Mode (Analog Fax Setup) 194
  - Fax Mode (Fax Server Setup) 202
  - Finishing 218
  - Flash Drive 211
  - FTP Settings 208
  - Help 228
  - HTML 226
  - Image 227
  - IPv6 169
  - LexLink 171
  - Miscellaneous 177
  - NetWare 170
  - Network <x> 164
  - Network Card 167
  - Network Reports 167
  - Paper Loading 158
  - Paper Size/Type 151
  - Paper Texture 155
  - Paper Weight 157
  - Parallel <x> menu 173
  - PCL Emul 223
  - PDF 222
  - PostScript 223
  - Quality 220
  - Reports 162
  - Security Audit Log 180
  - Serial <x> 175
  - Set Date/Time 181
  - Settings 181

- Setup 216
- SMTP Setup menu 166
- Standard Network 164
- Standard USB 171
- Substitute Size 155
- TCP/IP 167
- Universal Setup 161
- Utilities 221
- Wireless 169
- XPS 227
- Miscellaneous menu 177
- moving the printer 252, 253
- multiple pages on one sheet 97
- multipurpose feeder
  - loading 78

## N

- NetWare menu 170
- Network 233
- Network <x> 233
- Network <x> menu 164
- Network Card menu 167
- Network Reports menu 167
- network setup page 45
- No analog phone line connected to modem, fax is disabled. 234
- No answer 234
- No dial tone 234
- noise emission levels 289
- notices 285, 286, 287, 288, 289, 290, 291, 292, 293, 294

## O

- options
  - fax card 24, 41
  - firmware card 28
  - firmware cards 24
  - flash memory card 28
  - internal 24
  - Internal Solutions Port 31
  - memory card 27
  - memory cards 24
  - networking 24
  - ports 24
  - printer hard disk 37
- options, touch-screen
  - copy 100, 101, 102
  - e-mail 108, 109
  - fax 116, 117
  - FTP 122, 123
  - scan to computer 126, 127, 128

- ordering supplies 252
- output file type
  - changing 107

## P

- paper
  - characteristics 84
  - letterhead 85
  - preprinted forms 85
  - recycled 86
  - selecting 85
  - selecting weight 157
  - setting size 70
  - setting type 70
  - storing 86
  - unacceptable 85
  - Universal Paper Size 161
  - Universal size setting 70
- paper feed troubleshooting
  - message remains after jam is cleared 272
- paper jams
  - avoiding 138
- Paper Loading menu 158
- Paper Size/Type menu 151
- paper sizes
  - supported by the printer 87
- Paper Texture menu 155
- paper type
  - custom 82
- paper types
  - duplex support 89
  - supported by output bins 89
  - supported by printer 89
  - where to load 89
- Paper Weight menu 157
- paper weights
  - supported by output bins 89
- Parallel <x> menu 173
- PCL Emul menu 223
- PDF menu 222
- photos
  - copying 92
- port settings
  - configuring 55
- PostScript menu 223
- Power Saver
  - adjusting 255
- print job
  - canceling from Macintosh 136
  - canceling from Windows 136

- print quality
  - cleaning the scanner glass 248
- print quality test pages,
- printing 135
- print quality troubleshooting
  - blank pages 273
  - characters have jagged edges 274
  - clipped images 274
  - ghost images 274
  - gray background 275
  - poor transparency quality 283
  - print irregularities 276
  - print is too dark 280
  - print is too light 279
  - print quality test pages 273
  - repeating defects 277
  - skewed print 278
  - solid black streaks 278
  - solid color pages 281
  - solid white streaks 278
  - streaked vertical lines 281
  - toner fog or background shading 282
  - toner rubs off 282
  - toner specks 283
- print troubleshooting
  - error reading USB drive 257
  - held jobs do not print 258
  - incorrect characters print 259
  - incorrect margins 275
  - jammed page does not reprint 272
  - job prints from wrong tray 259
  - job prints on wrong paper 259
  - job takes longer than expected 259
  - jobs do not print 258
  - Large jobs do not collate 260
  - multiple-language PDFs do not print 257
  - paper curl 276
  - paper frequently jams 272
  - tray linking does not work 260
  - unexpected page breaks occur 260
- printer
  - configurations 14
  - minimum clearances 14, 253
  - models 14
  - moving 252, 253
  - selecting a location 14
  - setting up in new location 253
  - shipping 253
- printer control panel 17
  - factory defaults, restoring 256
- printer hard disk
  - installing 37
- printer messages
  - 1565 Emulation error, load emulation option 247
  - 200–282.yy paper jam 245
  - 283 Staple jam 245
  - 290–294.yy scanner jam 245
  - 293 Replace all originals if restarting job 245
  - 293.02 Flatbed Cover Open 246
- 30 Invalid refill, change cartridge 238
- 31 Replace defective cartridge 238
- 32 Cartridge part number unsupported by device 238
- 34 Short paper 239
- 35 Insufficient memory to support Resource Save feature 239
- 37 Insufficient memory for Flash Memory Defragment operation 239
- 37 Insufficient memory to collate job 239
- 37 Insufficient memory, some Held Jobs were deleted 239
- 37 Insufficient memory, some held jobs will not be restored 239
- 38 Memory full 240
- 39 Complex page, some data may not have printed 240
- 42.xy Cartridge region mismatch 240
- 50 PPDs font error 240
- 51 Defective flash detected 240
- 52 Not enough free space in flash memory for resources 241
- 53 Unformatted flash detected 241
- 54 Network <x> software error 241
- 54 Serial option <x> error 241
- 54 Standard network software error 241
- 55 Unsupported option in slot 242
- 56 Parallel port <x> disabled 242
- 56 Serial port <x> disabled 242
- 56 Standard parallel port disabled 242
- 56 Standard USB port disabled 242
- 56 USB port <x> disabled 243
- 57 Configuration change, held jobs were not restored 243
- 58 Too many bins attached 243
- 58 Too many disks installed 243
- 58 Too many flash options installed 243
- 58 Too many trays attached 244
- 59 Incompatible envelope feeder 244
- 59 Incompatible output bin <x> 244
- 59 Incompatible tray <x> 244
- 61 Remove defective disk 244
- 62 Disk full 244
- 63 Unformatted disk 245
- 80 Routine maintenance needed 245
- 840.01 Scanner Disabled 246
- 841–846 Scanner Service Error 246
- 88 Cartridge low 245
- 88.yy Cartridge nearly low 245
- 88.yy Replace cartridge 245
- 900–999 Service <message> 246

- Insert staple cartridge 231
  - Insert Tray <x> 232
  - Install bin <x> 232
  - Install envelope feeder 232
  - Install tray <x> 232
  - Invalid PIN 232
  - Job stored for delayed transmission 233
  - Line busy 233
  - Load <src>with <x> 233
  - Load manual feeder with <x> 233
  - Load staples 233
  - Memory full, cannot print faxes 233
  - Network 233
  - Network <x> 233
  - No analog phone line connected to modem, fax is disabled. 234
  - No answer 234
  - No dial tone 234
  - Queued for sending 234
  - Ready 234
  - Reattach bin <x> 234
  - Reattach bin <x> – <y> 235
  - Reattach envelope feeder 235
  - Receive complete 235
  - Receiving page <n> 236
  - Remove packaging material, check <x> 236
  - Remove paper from <linked bin set name> 236
  - Remove paper from all bins 236
  - Remove paper from bin <x> 236
  - Remove paper from standard output bin 236
  - Replace all originals if restarting job. 236
  - Replace wiper 237
  - Restore Held Jobs? 237
  - Scan Document Too Long 237
  - Scanner ADF Cover Open 237
  - Scanner Jam Access Cover Open 237
  - Securely clearing disk space 237
  - Sending page <n> 237
  - Serial <x> 237
  - Set clock 237
  - SMTP server not set up. Contact system administrator. 237
  - Some held jobs were not restored 238
  - System busy, preparing resources for job. 238
  - System busy, preparing resources for job. Deleting held job(s). 238
  - Unsupported disk 238
  - Unsupported USB device, please remove 238
  - Unsupported USB hub, please remove 238
  - USB/USB <x> 238
  - Waiting for redial 238
  - printer options troubleshooting
    - 2000-sheet tray 270
    - 4-bin mailbox 271
    - envelope feeder 270
    - flash memory card 271
    - hard disk with adapter 271
    - high capacity output expander 271
    - Internal Solutions Port 271
    - memory card 271
    - option not working 269
    - paper trays 269
    - StapleSmart finisher 271
  - printer problems, solving
    - basic 257
  - printing
    - directory list 135
    - from flash drive 134
    - from Macintosh 129
    - from Windows 129
    - installing printer software 45
    - menu settings page 44
    - network setup page 45
    - print quality test pages 135
  - printing confidential and other held jobs
    - from Macintosh computer 133
    - from Windows 132
  - recycled paper
    - using 86
  - reducing a copy 95
  - Remove packaging material, check <x> 236
  - Remove paper from <linked bin set name> 236
  - Remove paper from all bins 236
  - Remove paper from bin <x> 236
  - Remove paper from standard output bin 236
  - Repeat print jobs 132
    - printing from Macintosh computer 133
    - printing from Windows 132
  - Replace all originals if restarting job. 236
  - Replace wiper 237
  - reports
    - viewing 255
  - Reports menu 162
  - Reserve print jobs 132
    - printing from Macintosh computer 133
    - printing from Windows 132
  - resolution, fax
    - changing 114
  - Restore Held Jobs? 237
  - RJ11 adapter, using 60
- S**
- safety information 12, 13
  - Scan Document Too Long 237
  - scan quality, improving 128
  - scan troubleshooting
    - cannot scan from a computer 265
    - partial document or photo scans 264
    - scan was not successful 263
    - scanner unit does not close 261
    - scanning takes too long or freezes the computer 264
  - scanner
    - Automatic Document Feeder (ADF) 16
    - functions 15
    - registration 249
    - scanner glass 16
  - Scanner ADF Cover Open 237
  - scanner glass
    - cleaning 248

- scanner glass (flatbed)
    - copying using 92
  - Scanner Jam Access Cover Open 237
  - scanning to a computer 125
    - improving scan quality 128
  - scanning to a flash drive 126
  - scanning to an FTP address
    - creating shortcuts using the computer 121
    - creating shortcuts using the touch screen 122
    - improving FTP quality 124
    - using shortcut numbers 121
    - using the address book 121
    - using the keypad 120
  - Securely clearing disk space 237
  - Security Audit Log menu 180
  - Sending page <n> 237
  - Serial <x> 237
  - Serial <x> menu 175
  - serial port 57
  - serial printing
    - setting up 57
  - Set clock 237
  - Set Date/Time menu 181
  - setting
    - paper size 70
    - paper type 70
    - TCP/IP address 167
    - Universal Paper Size 70
  - setting up
    - serial printing 57
  - setting up the printer
    - on a wired network (Macintosh) 52
    - on a wired network (Windows) 52
  - Settings menu 181
  - Setup menu 216
  - shipping the printer 253
  - shortcuts, creating
    - e-mail 105
    - fax destination 112, 113
    - FTP destination 121, 122
  - SMTP server not set up. Contact system administrator. 237
  - SMTP Setup menu 166
  - Some held jobs were not restored 238
  - Standard Network menu 164
  - standard tray
    - loading 71
  - Standard USB menu 171
  - status of supplies, checking 251
  - storing
    - paper 86
    - supplies 250
  - subject and message information
    - adding to e-mail 107
  - Substitute Size menu 155
  - supplies
    - conserving 251
    - status of 251
    - storing 250
  - supplies, ordering 252
  - system board
    - accessing 25
  - System busy, preparing resources for job. 238
  - System busy, preparing resources for job. Deleting held job(s). 238
- T**
- TCP/IP menu 167
  - telecommunication notices 290, 291, 292
  - touch screen
    - buttons 20
  - transparencies
    - loading 78
    - making 92
    - tips on using 130
  - tray linking 82
  - tray unlinking 82
  - trays
    - linking 81, 82
    - unlinking 82
  - troubleshooting
    - checking an unresponsive printer 257
    - checking an unresponsive scanner 263
    - contacting Customer Support 284
    - solving basic printer problems 257
  - troubleshooting, copy
    - copier does not respond 261
    - partial document or photo copies 263
    - poor copy quality 261
    - poor scanned image quality 264
  - scanner unit does not close 261
  - troubleshooting, display
    - display is blank 257
    - display shows only diamonds 257
  - troubleshooting, fax
    - blocking junk faxes 115
    - caller ID is not shown 265
    - can receive but not send faxes 268
    - can send but not receive faxes 267
    - cannot send or receive a fax 265
    - received fax has poor print quality 268
  - troubleshooting, paper feed
    - message remains after jam is cleared 272
  - troubleshooting, print
    - error reading USB drive 257
    - held jobs do not print 258
    - incorrect characters print 259
    - incorrect margins 275
    - jammed page does not reprint 272
    - job prints from wrong tray 259
    - job prints on wrong paper 259
    - job takes longer than expected 259
    - jobs do not print 258
    - Large jobs do not collate 260
    - multiple-language PDFs do not print 257
    - paper curl 276
    - paper frequently jams 272
    - tray linking does not work 260
    - unexpected page breaks occur 260
  - troubleshooting, print quality
    - blank pages 273
    - characters have jagged edges 274
    - clipped images 274
    - ghost images 274
    - gray background 275
    - poor transparency quality 283
    - print irregularities 276
    - print is too dark 280
    - print is too light 279
    - print quality test pages 273
    - repeating defects 277
    - skewed print 278

- solid black streaks 278
- solid color pages 281
- solid white streaks 278
- streaked vertical lines 281
- toner fog or background shading 282
- toner rubs off 282
- toner specks 283
- troubleshooting, printer options
  - 2000-sheet tray 270
  - 4-bin mailbox 271
  - envelope feeder 270
  - flash memory card 271
  - hard disk with adapter 271
  - high capacity output expander 271
  - Internal Solutions Port 271
  - memory card 271
  - option not working 269
  - paper trays 269
  - StapleSmart finisher 271
- troubleshooting, scan
  - cannot scan from a computer 265
  - partial document or photo scans 264
  - scan was not successful 263
  - scanner unit does not close 261
  - scanning takes too long or freezes the computer 264

## U

- Universal Paper Size
  - setting 70
- Universal Setup menu 161
- unlinking trays 82
- Unsupported disk 238
- Unsupported USB device, please remove 238
- Unsupported USB hub, please remove 238
- USB port 43
- USB/USB <x> 238
- using RJ11 adapter 60
- Utilities menu 221

## V

- Verify print jobs 132
  - printing from Macintosh computer 133
  - printing from Windows 132

- viewing
  - reports 255

## W

- Waiting for redial 238
- Windows
  - wireless network installation 47
- wired network setup
  - using Windows 52
- wired networking
  - using Macintosh 52
- Wireless menu 169
- wireless network
  - configuration information 47
  - installation, using Macintosh 49
  - installation, using Windows 47

## X

- XPS menu 227